

 **FIRST**





FIRST ITALIA S.R.L.

strada della Berlia, 80 - 10093 Collegno (TO) - ITALY
tel. +39.011.712216- fax +39.011.712105
e-mail: commerciale@firstitaly.it

www.firstitaly.it

L'AZIENDA

L'entreprise

Un'azienda leader nella produzione industriale di lame circolari:

First Italia è un'azienda che, in oltre 50 anni di esperienza, si è affermata come punto di riferimento per chi cerca l'affidabilità e la qualità produttiva. L'eccellenza First Italia è il frutto dell'unione tra l'esperienza artigiana e la più moderna tecnologia industriale.

First Italia è specializzata nella creazione di strumenti da taglio. Lame scolpite al laser, pensate e progettate per incidere con precisione e semplicità tutti i tipi di materiale, dal legno tenero al ferro più resistente.

Ogni lama First Italia è specificamente ideata e realizzata per facilitare il lavoro dei professionisti e garantire un output produttivo sempre all'avanguardia. Un'azienda che da sempre ha come obiettivo rendere il lavoro più facile.

Il ciclo produttivo First Italia avviene sotto l'occhio attento di operatori di controllo specializzati ed è svolto da un sistema computerizzato ad alta precisione, questo approccio, dove l'abilità artigiana viene supportata dall'alta tecnologia, garantisce degli standard produttivi elevatissimi.

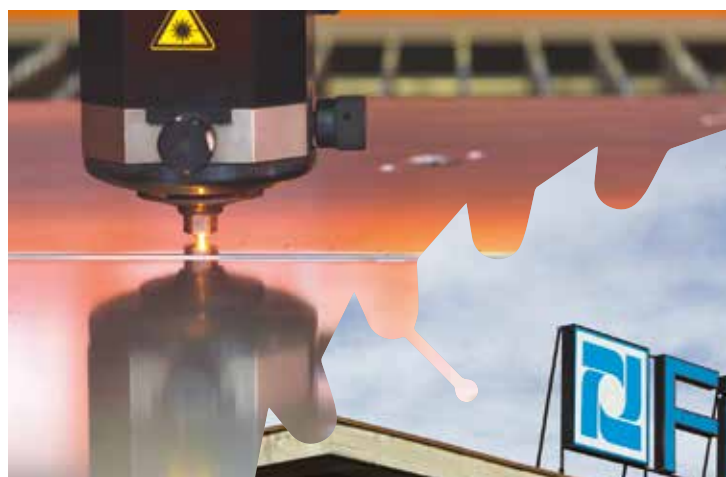

Une entreprise leader dans la production industrielle de lames circulaires:

First Italia est une entreprise qui, grâce à ses 50 ans d'expérience, s'est consolidée comme référence pour tous ceux qui exigent fiabilité et qualité de production. L'excellence First Italia est le résultat de l'union entre l'expérience artisanale et la technologie industrielle la plus moderne.

First Italia est spécialisée dans la création d'outils de coupe. Lames sculptées au laser, conçues et projetées pour inciser avec précision et simplicité tous les types de matériau, du bois tendre au fer le plus résistant.

Toutes les lames First Italia sont spécifiquement conçues et fabriquées pour faciliter le travail des professionnels et garantir une production toujours à l'avant-garde. Une entreprise qui a, depuis toujours, pour objectif de faciliter le travail.

Le cycle de production First Italia se déroule sous le regard attentif d'opérateurs de contrôle spécialisés, assistés par un système informatisé haute précision ; cette approche, où l'habileté artisanale est supportée par la haute technologie, garantit d'excellents standards de production.



THE COMPANY

La empresa

🇬🇧 — A Leader Company
in the Industrial production
of circular blades:

First Italia is a company, with over 50 years of experience, which has now become a benchmark for productive quality and reliability. The First Italia excellence is the result of the union between artisanal experience and the most modern industrial technology.

First Italia is specialized in the creation of cutting instruments. Blades shaped by laser, thought and designed to engrave with precision and simplicity any type of material, from soft wood to the most resistant metal alloys.

Each step of the First Italia productive cycle happens under the scrutiny of specialized control operators and a high precision computerized system, this approach, where artisanal know-how is supported by high technology, guarantees extremely high productive standards.

🇪🇸 — Una empresa líder
en la producción industrial
de cuchillas circulares:

First Italia es una empresa que, con más de 50 años de experiencia, se ha consolidado como un punto de referencia para quien busca la fiabilidad y la calidad productiva. La excelencia First Italia es el resultado de la unión entre la experiencia artesana y la tecnología industrial más moderna.

La empresa First Italia está especializada en la creación de herramientas de corte. Cuchillas esculpidas con láser, concebidas y diseñadas para grabar con precisión y facilidad en todo tipo de materiales, desde la madera blanda hasta el hierro más resistente.

Cada cuchilla First Italia ha sido diseñada y realizada específicamente para facilitar el trabajo de los profesionales y garantizar un rendimiento productivo siempre a la vanguardia. Una empresa que, desde siempre, tiene como objetivo hacer que el trabajo sea más sencillo.

El ciclo productivo First Italia se lleva a cabo bajo la atenta mirada de los operadores de control especializados, asistidos por un sistema computarizado de alta precisión. Este enfoque, donde la habilidad artesana es apoyada por una alta tecnología, garantiza estándares de calidad muy elevados.



INDICE

Contents | Index | Índice

INTRODUZIONE

L'azienda L'entreprise The company La empresa	— 02
Descrizione tecnica Description technique Technical data Descripción técnica	— 04
Indicazioni di taglio Indications de coupage Cutting details Indicaciones de corte	— 06
Dentature maggiormente utilizzate Dentures les plus utilisées Most used cutting edges Dentados más utilizados	— 08
Scelta del tipo di lama Choix du type de lame How to choose the perfect blade Elección del tipo de cuchilla	— 10
Diversi tipi di taglio Différent types de coupe Different cutting types Diferentes tipos de corte	— 11

TAGLIO LEGNO

COUPE BOIS - WOOD CUTTING - CORTE MADERA

Lame universali

Lames universelles | Universal saw blades |
Cuchillas universales

Norma	— 14
Linx	— 15
Eleth	— 16
Gamma	— 18

Lame industriali

Lames industrielles | Industrial saw blades |
Cuchillas industriales

Indus	— 22
Mizar	— 24
Zenit	— 28
Sharp	— 29
Tauri	— 30
Thyco	— 31
Rigel	— 32
Lame per macchine Lamello	— 33
Lame a forte spessore per incastri	— 34
Lame al cromo vanadio	— 34
Thorex coltelli pialla	— 35

Accessori

Accessoires | Accessories |
Accesorios

Anelli di riduzione	— 35
------------------------	------

TAGLIO METALLO

COUPE METAL - METAL CUTTING - CORTE METAL

Thorex

Algor	— 38	Lame circolari	— 42
F5-HW	— 40	Seghe a nastro bimetalliche	— 46

 __ Lame circolari:

 __ Circular blades:

 __ Lames circulaires:

 __ Cuchillas circulares:

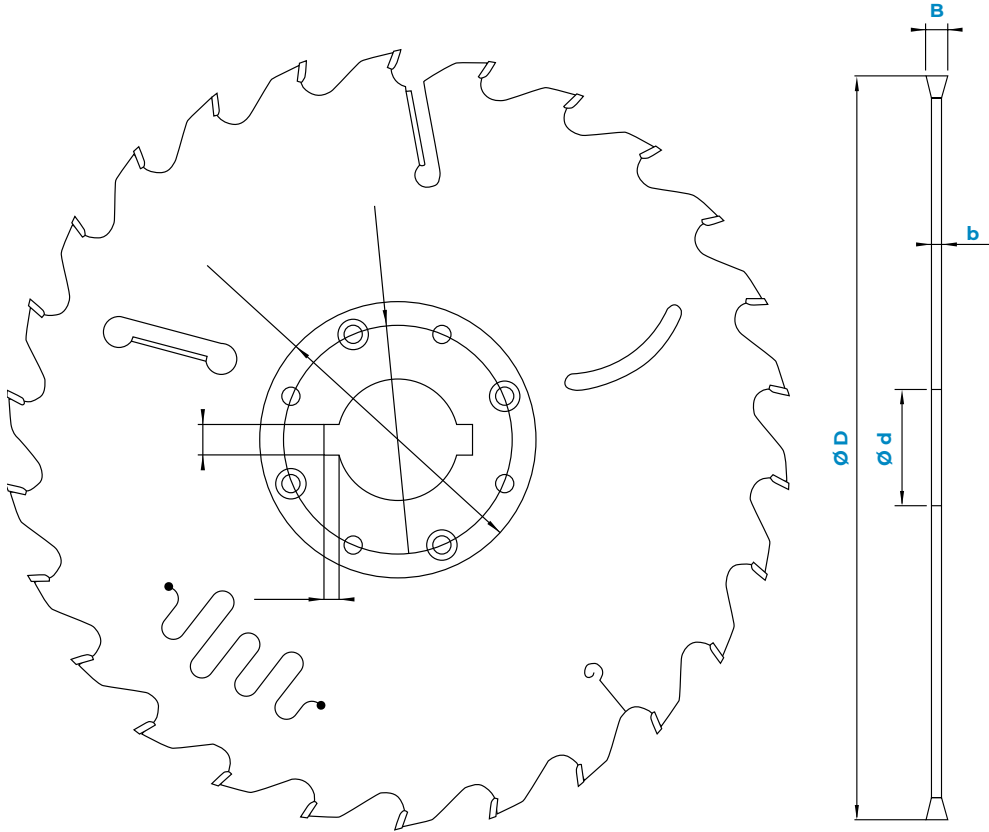

- D** | Diametro
Diamètre
Diameter
Diámetro
- B** | Spessore del dente
Épaisseur du dent
Teeth thickness
Espesor del diente
- b** | Spessore del corpo
Épaisseur du corp
Body thickness
Espesor del cuerpo
- Z** | N° denti
Dents
Teeth
Dientes
- d** | Foro
Alésage
Bore
Agujero

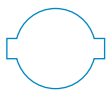

Foro centrale con chiavette
Alésage et rainure de clavette
Bore and keyways
Eje y ranura de chavetas

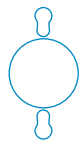

Foro centrale e fori di trascinamento
Alésage et trou d'entraînement
Bore and pin hole
Eje y agujero de arrastre



Rasante esterno
Racleur extérieur
External rakers
Raspado externo



Taglio di dilatazione
Fente de dilatation
Expansion slots
Ranura de dilatación



Rasante interno
Racleur intérieur
Inner rakers
Raspador interno



Taglio di raffreddamento
Fente de ventilation
Cooling slot
Ranura de ventilación



Taglio antirumore
Fente de dilatation Anti-Bruit
Anti noise slot
Ranura de dilatación anti-ruído



Foro di fissaggio con svasatura
Trou d'ergot à tête fraisée
Drilled pin hole
Ojo de clavo con cabeza fresada



Foro di fissaggio standard
Trou d'ergot standard
Standard pin hole
Ojo de clavo estándar

Indicazioni per ottenere il miglior risultato nell'impiego delle lame circolari "First"

Per ottenere il miglior risultato nell'impiego delle nostre lame circolari occorre attenersi ad alcune norme fondamentali:

- Assoluta mancanza di vibrazioni della macchina e dell'albero portautensile.
- Le flange impiegate per il blocco della lama devono avere un diametro pari ad almeno un terzo di quello della circolare ed inoltre la loro tolleranza non deve essere superiore a 0,02 mm.
- Il taglio non deve fuoriuscire dal materiale oltre a 10 - 15mm.
- La lama deve essere costantemente lavata con soluzioni che eliminano l'incrostazione della segatura o delle resine.
- La riaffilatura della lama deve essere eseguita su macchine di estrema precisione, impiegando mole diamantate e deve essere effettuata ogni qual volta i taglienti presentino un arrotondamento superiore a 0,2 - 0,3 mm.
- Il numero massimo dei giri, nell'impiego di una circolare, quale valore indicativo per un limite di sicurezza, senza tuttavia pregiudicare l'impiego della lama, è indicato nella tabella 1.

— Valori indicativi di lavoro

La **velocità di avanzamento**, legata al tipo di materiale, allo spessore, al numero dei taglienti impiegati ed alla velocità di taglio unitamente al grado di finitura richiesto, si può riassumere nella tabella 2.

La **velocità di taglio** dei vari tipi di materiali si può indicare come da tabella 3.

Indications pour obtenir le meilleur resultat dans l'emploi des lames circulaires "First"

Afin d'obtenir le meilleur rendement de nos lames de scies circulaires, nous vous conseillons d'observer quelques règles d'utilisation fondamentales:

- Aucune vibration ne doit être ressentie sur la machine ou l'arbre porte outils.
- Les flasques de serrage de la lame doivent avoir un diamètre au moins égal à un tiers de celui de la lame, en outre leur tolérance en épaisseur ne doit pas être supérieure à 0,02 mm.
- Lors de la coupe, la lame doit dépasser du bois de plus de 10 à 15 mm.
- Afin d'éliminer le dépôt de sciure ou résine, il est conseillé de lubrifier avec une solution liquide appropriée.
- L'affûtage des lames doit être exécuté sur des machines travaillant sous arrosage avec des meules diamant ou borazon. Ne pas attendre pour affûter les lames que l'usure de la pastille soit supérieure à 0,2 - 0,3 mm.
- Pour un emploi des lames en toute sécurité, ne pas dépasser la vitesse de rotation maximale indiquée dans le tableau 1.

— Valeurs indicatives du travail

La **vitesse d'avancement**, liée au type de matériel à l'épaisseur, au nombre de trachants employés et à la rapidité de coupe ainsi que le degré de finition demandé, peut être résumé dans le tableaux 2.

La **vitesse de coupe** dans les différents types de matériaux, peut être indiquée dans le tableaux 3.

TAB 1

DIAMETRO - DIAMÈTRE - DIAMETER - DIÁMETRO (mm)													
100	125	150	160	180	200	250	300	350	400	450	500	550	600
N°MAX GIRI/MIN. - TOURS PAR MINUTE - R.P.M - R.P.M.													
15.000	13.000	12.000	11.000	10.000	9.000	7.000	6.000	5.000	4.500	4.000	3.500	3.000	2.800

🇬🇧 — Indications for obtaining the best results when using “First” circular blades

In order to get the best results out of our T.C.T. circular saw blades, please respect the following recommendations:

- No vibrations at all on your machine and on the tool axis holder.
- Diameter of flanges must be at least equivalent to one third of diameter of the Circular saw blade. Moreover the tolerance has to be of 0,02 mm maximum.
- The blade cut must exceed the wood material by more than 10 - 15 mm.
- The circular saw blades has to be cleaned regularly with appropriate cleaning liquid. This is in order to avoid the creation of a harmful crust (saw dust and resin).
- Re-sharpening of the saw has to be made on a very precise machine working with diamond wheels. This re-sharpening has to be made before the weaving of the cutting edges goes over 0,2 - 0,3 mm.
- The table 1 gives you an indicative security RPM which also prevents from prejudicial use of the circular saw blade.

— Indicative working values

The **feeding speed**, together with the type of material, the thickness, the number of cutting teeth used and the cutting speed besides the grade of finish required can be summarized in the table 2.

The **cutting speed** in the various types of materials are indicated in the table 3.

TAB 2

Legni teneri - Bois tendres Soft woods - Maderas blandas	10/40 m/min
Legni duri - Bois durs Hard woods - Maderas duras	10/30 m/min
Legni compensati / Truciolare Bois contreplaqués - Plywoods Terciados y aglomerados	10/20 m/min
Materiali plastici - Matériaux plastiques Plastic materials - Materiales plasticos	5/100 m/min

🇪🇸 — Indicaciones para obtener el mejor resultado de empleo de las cuchillas de sierra circular “First”

Para llegar al mejor uso de nuestras cuchillas de sierra le rogamos seguir unas normas fundamentales:

- No se debe notar alguna vibración en el eje soporte sierra;
- Los casquillos deben ser a lo mínimo de un diámetro de un tercio de la sierra. La tolerancia no puede ser más de 0,02 mm.
- La sierra no debe sobresalir del material de más de 10 a 15 mm.
- La hoja debe ser lubricada constantemente con el liquido adecuado o con otras soluciones eliminando la costras formada con el serrín y la resina.
- El afilado de las sierras debe estar hecho con máquinas de alta precisión utilizando esmeriles diamante o borazón. Se debe afilar una sierra cada vez que el filo cortador se encuentra embotado de más de 0,2 - 0,3 mm.
- El número de vueltas máximo en el uso de la sierras circulares como valor indicativo para cumplir a las normas de seguridad está dado en la tabla 1.

— Valores indicativos de trabajo

La **velocidad de avance**, ligada al tipo de material, al espesor, al número de dientes empleados, y a la velocidad de corte conjuntamente al grado de terminación deseado, se puede resumir en la tabla 2.

La **velocidad de corte** para los distintos tipos de materiales se puede indicar como en la tabla 3.

TAB 3

Legni teneri - Bois tendres Soft woods - Maderas blandas	60/90 m/sec
Legni duri - Bois durs Hard woods - Maderas duras	50/70 m/sec
Legni compensati / Truciolare Bois contreplaqués - Plywoods Terciados y aglomerados	60/80 m/sec
Materiali plastici - Matériaux plastiques Plastic materials - Materiales plasticos	25/60 m/sec
Alluminio - Aluminium Aluminium - Aluminio	20/30 m/sec

— Dentature maggiormente utilizzate

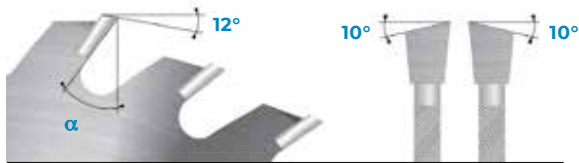

— Dentures les plus utilisées

Dentatura Alternata

Dentatura universale, taglio lungovena e trasversale di legni in genere, compensati, faesite, multistrato, ecc.

Denture alternée

Denture universelle, pour la coupe en longueur et transversal du bois en general, des contreplaqués, faesite, feuillettes, etc.

Alternate teeth

Universal teeth, lengthwise and crosswise cut of woods, plywood, particle board, hard board, etc.

Diente alterno

Diente universales, para el corte longitudinal y transversal de madera en general, contrachapados, aglomerados, multilaminados, etc.

Dentatura trapezio-piana positiva

Taglio di profilati in alluminio anodizzato o leghe in metallo non ferroso. Adatta anche per il taglio di bilaminati e MDF.

Denture trapézoïdale-plate positive

Pour la coupe de profiles en aluminium anodisé au alliage en métal non ferreux. Appropriée pour la coupe des panneaux en mélamine et MDF.

Trapezoidal-flat teeth positive

For cutting anodized aluminium profiles or non ferrous metal alloys. Can be used for the cutting of bi-laminates and MDF.

Diente recto y trapezoidal-positivo

Para el corte de perfiles de aluminio y aleaciones ligeras no férricas. Apto también para el corte de laminados doble cara y MDF.

Dentatura trapezio-piana negativa

Taglio di profilati in alluminio anodizzato o leghe in metallo non ferroso.

Denture trapézoïdale-plate negative

Pour la coupe de profiles en aluminium anodisé ou alliage en métal non ferreux.

Trapezoidal-flat teeth negative

For cutting anodized aluminium profiles or non ferrous metal alloys.

Diente recto y trapezoidal negativo

Para el corte de perfiles de aluminio y aleaciones ligeras no férricas.

🇬🇧 — Most used
teeth shape



🇪🇸 — Dentados
más utilizados

Dentatura Piatta

Utilizzata su lame multilame, per incastri e Lamello.

Denture Plate

Utilisée sur lames multilame, pour rainures et Lamello.

Flat Teeth

Used on multi-blade blades, for joints and Lamello.

Diente plano

Utilizado por sierras con cuchillas múltiples, por ranuras y Lamello.

Dentatura concava

Taglio specifico di laminati. Impiego su sezionatrici verticali senza incisore.

Denture gouge

Pour le débit de panneaux revêtus une et deux faces. Pour l'emploi sur machines à sectionner verticales, sans lame incisives.

Hollow ground teeth

For cutting laminated on one or both sides. Suitable for use on vertical sectioning machines, without scoring saw.

Diente cóncavo

Para el corte de laminados en una y ambas caras. Indicada para al empleo sobre seccionadoras verticales, sin grabador.

Dentatura conica

Indicata per l'impiego su sezionatrici. Possibilità di variare la larghezza di incisione.

Denture conique

Indiqué pour l'emploi sur des machines à sectionner. Possibilité de varier la largeur de l'incision.

Conical teeth

Suitable for using on sectioning machines. Enables to change the cutting width.

Diente cónico

Para el empleo en máquinas seccionadoras. Posibilidad de variar el ancho de corte.

— Scelta del tipo di lama

Per stabilire approssimativamente il **numero dei taglienti** di una lama circolare occorre tenere presente il tipo di materiale da tagliare ed il suo spessore, l'avanzamento del materiale, il grado di finitura desiderato, la velocità di taglio in modo che tre taglienti si trovino contemporaneamente in azione. Per ottenere una buona finitura di taglio occorre abbinare la più alta velocità d'avanzamento al maggior numero di taglienti.

Per la scelta di **tipo di lama circolare**, vi preghiamo di consultare il presente catalogo dove ad ogni tipo di lama è indicato approssimativamente l'uso a cui è destinato.

Per le ordinazioni vi preghiamo di attenervi per quanto possibile ai tipi indicati nel catalogo, mentre il nostro Ufficio Tecnico è a completa disposizione della clientela per soddisfare, per quanto possibile, particolari esigenze di lavorazione.

— How to choose the perfect blade

To establish approximately the **number of cutting teeth** of a circular blade it is necessary to bear in mind the type of material to be cut, the thickness, the feeding speed, the grade of finish required, the cutting speed so that three cutting edges are simultaneously in action. To obtain a good finish the highest feeding speed must be combined with the major number of cutting teeth.

To select the correct **type of circular blade** we ask you to consult the present catalogue, where the general uses of each blade are indicated.

When ordering we ask you to use possibly the types indicated in the catalogue, while our Technical Office is at the complete disposal of clients and will do its best to satisfy special working requirements.

— Choix du type de lame

Pour établir approximativement le **nombre des dents** d'une lame circulaire, il faut tenir compte du type de matériaux à couper, de son épaisseur, de l'avancement du matériau, du degré de finition désiré, de la rapidité de coupe de façon que 3 tranchants se trouvent en action au même temps. Pour obtenir une bonne finition de la coupe, il faut combiner la vitesse d'avancement la plus importante et le plus grand nombre des dents.

Pour le choix du **type de lame circulaire**, nous vous prions de consulter le présent catalogue, où à chaque type de lame correspond approximativement l'usage auquel elle est destinée.

Pour les commandes, nous vous prions de vous tenir dans la mesure possible aux types indiqués dans le catalogue, alors que notre Service Technique est à complète disposition de la Clientèle pour satisfaire dans la mesure du possible, des exigences de travail particulières.

— Elección del tipo de cuchilla

Para establecer aproximadamente el **número de dientes** de una sierra circular es necesario tener presente el tipo de material a cortar, su espesor, el avance del material, el grado de terminación deseado y la velocidad de corte en modo tal que tres dientes se encuentren contemporáneamente en acción. Para obtener una buena terminación de corte es necesario reunir a la vez la más alta velocidad de avance al mayor número de dientes.

Para la selección del **tipo de sierra circular** rogamos consultar el presente catálogo donde para cada tipo de hoja está indicado aproximadamente el uso al cual está destinada.













Para los pedidos rogamos de atenerse en lo posible a los tipos indicados en el catálogo; sin embargo nuestra Oficina Técnica está a completa disposición de la clientela para satisfacer, en lo posible, particulares exigencias de elaboración.

 __ Diversi tipi di taglio

 __ Different cutting types

 __ Différent types de coupe

 __ Diferentes tipos de corte

→	<p>Taglio longitudinale Délignage Ripping Corte longitudinal</p>	⇒	<p>Taglio lungo vena multiplo Délignage multiple Multi-ripping Corte longitudinal múltiplo</p>	↑	<p>Taglio trasversale Tronçonnage Cross-cut Corte transversal</p>
	<p>Legno tenero Bois tendres Soft wood Maderas blandas</p>		<p>Legno duro Bois durs Hard woods Maderas duras</p>		<p>Esotico / pregiato Exotique / rare Exotic / prized Exóticas / valiosas</p>
	<p>Compensato Contreplaqués Plywood Contrachapado</p>		<p>Truciolare Panneaux de particules Chipboard Conglomerado</p>		<p>Multistrato Paquets Multi-boards Paquetes</p>
	<p>Laminato Stratifié Laminates Laminado</p>		<p>Bilaminato Stratifié double face Bi-laminates Doble laminado</p>		<p>Plastica Plastique Plastic Plástico</p>
	<p>Ferro Fer Iron Hierro</p>		<p>Alluminio profilato Aluminium profilé Aluminum profiled Aluminio perfilado</p>		<p>Alluminio pieno Aluminium plein Solid aluminum Aluminio lleno</p>



TAGLIO LEGNO

COUPE BOIS

WOOD CUTTING

CORTE MADERA

NORMA

Lame universali per legno

Lames circulaires universelle pour bois

Universal TCT circular saw blades for wood

Cuchillas universales para el corte de madera



Lame per tagli longitudinali e trasversali.
Dentatura alternata.



Lames universelles pour bois, pour des coupes
longitudinales et transversales. Denture alternée.



Universal blades for wood, suitable both for
lengthwise and crosswise cutting. Alternate teeth.



Cuchillas universales para madera, para cortes
longitudinales y transversales. Diente alterno.

	D mm	B/b mm	d mm	Z	€
LC3002416	300	3,2 - 2,2	30	24	50,00
LC3004808	300	3,2 - 2,2	30	48	60,00
LC3152407	315	3,2 - 2,2	25,4	24	53,00
LC3152408	315	3,2 - 2,2	30	24	53,00
LC3154804	315	3,2 - 2,2	25,4	48	64,00
LC3154805	315	3,2 - 2,2	30	48	64,00
LC3502811	350	3,2 - 2,2	30	28	60,00
LC3504204	350	3,2 - 2,2	30	42	63,00
LC3505411	350	3,2 - 2,2	30	54	65,00
LC4003210	400	3,5 - 2,5	30	32	72,00
LC4004803	400	3,5 - 2,5	30	48	79,00
LC4503607	450	3,5 - 2,5	30	36	100,00
LC4505407	450	3,5 - 2,5	30	54	123,00
LC5004008	500	3,5 - 2,5	30	40	118,00
LC5006005	500	3,5 - 2,5	30	60	140,00
LC5504406	550	4,0 - 2,8	30	44	147,00
LC5506003	550	4,0 - 2,8	30	60	165,00
LC6004807	600	4,0 - 2,8	30	48	158,00
LC6007202	600	4,0 - 2,8	30	72	180,00
LC7006001	700	4,2 - 3,2	30	60	195,00

Fori di trascinamento - Trous d'entrainement

Pinholes - Agujeros de arrastre

da D Ø 250 a D Ø 350 = 2/7/42 + 2/9/46,35 + 2/10/60

da D Ø 400 a D Ø 600 = 2/10/60

α = da 12° a 20°



LYNX

Lame circolari con limitatore di truciolo
 Lames circulaires avec limiteur de copeaux
 TCT circular saw blades with chip limiting device
 Cuchillas circulares con limitador de viruta

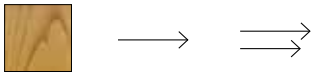
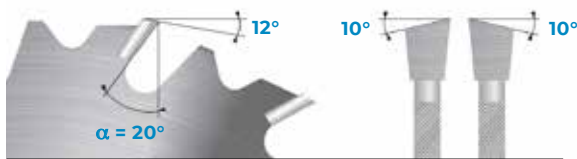

Lame con limitatore di truciolo. Ideali per il legno tenero e il tavolame da cantieristica. Taglio senza contraccolpi. Dentatura alternata.



Lames avec limiteur de copeaux. Idéales pour le bois tendre et le bois en plateaux pour chantier. Coupe sans contrecoup. Denture alternée.



Circular saw blades with chip limiting device. They are specifically good to be used in carpentry works for the cutting of boardings. Cutting without blowback. Alternate teeth.



Cuchillas con limitador de viruta. Ideales para la madera blanda y los paneles de encofrado en zona de obras. Corte sin contragolpes. Diente alterno.

	D mm	B/b mm	d mm	Z	€
LC2502402	250	3,2 - 2,2	30	24	48,00
LC3002401	300	3,2 - 2,2	30	24	50,00
LC3152404	315	3,2 - 2,2	25,4	24	53,00
LC3152405	315	3,2 - 2,2	30	24	53,00
LC3502807	350	3,2 - 2,2	30	28	60,00
LC3502801	350	3,5 - 2,5	30	28	67,00
LC4003208	400	3,5 - 2,5	30	32	72,00
LC4003201	400	3,8 - 2,8	30	32	79,00
LC4503605	450	3,5 - 2,5	30	36	100,00
LC4503601	450	4,0 - 2,8	30	36	110,00
LC5004006	500	3,5 - 2,5	30	40	118,00
LC5004002	500	4,0 - 2,8	30	40	130,00
LC5504404	550	4,0 - 2,8	30	44	147,00
LC6004801	600	4,0 - 2,8	30	48	158,00
LC7004602	700	4,2 - 3,2	30	46	170,00

Fori di trascinamento - Trous d'entraînement
 Pinholes - Agujeros de arrastre

da D Ø 250 a D Ø 350 = 2/7/42 + 2/9/46,35 + 2/10/60
 da D Ø 400 a D Ø 600 = 2/10/60

$\alpha = 20^\circ$



ELETH I

Lame circolari per macchine portatili
 Lames circulaires pour machines portatives
 TCT circular saw blades for portable machines
 Cuchillas circulares para máquinas portátiles



Taglio lungo vena di legni duri e teneri.
 Dentatura alternata.



Coupe longitudinale de bois durs et tendres.
 Denture alternée.



Lengthwise grain cut of both hard and soft woods.
 Alternate teeth.



Corte a lo largo de la vena de maderas blandas
 y duras. Diente alterno.

	D mm	B/b mm	d mm	Z	€
LC1252002	125	2,5 - 1,6	20	20	29,00
LC1302001	130	2,5 - 1,6	20	20	29,00
LC1402001	140	2,5 - 1,6	20	20	29,00
LC1502405	150	2,5 - 1,6	20	24	30,00
LC1602405	160	2,5 - 1,6	20	24	30,00
LC1602408	160	2,5 - 1,6	30	24	30,00
LC1652402	165	2,5 - 1,6	20	24	31,00
LC1652403	165	2,5 - 1,6	30	24	31,00
LC1702401	170	2,5 - 1,6	30	24	31,00
LC1802406	180	2,5 - 1,6	20	24	31,00
LC1802407	180	2,5 - 1,6	30	24	31,00
LC1902411	190	2,5 - 1,6	20	24	31,00
LC1902412	190	2,5 - 1,6	30	24	31,00
LC2002406	200	2,8 - 1,8	30	24	36,00
LC2102405	210	2,8 - 1,8	30	24	38,00
LC2162402	216	2,8 - 1,8	30	24	38,00
LC2202406	220	2,8 - 1,8	30	24	38,00
LC2302405	230	2,8 - 1,8	30	24	40,00
LC2352407	235	2,8 - 1,8	30	24	40,00
LC2402402	240	2,8 - 1,8	30	24	40,00

$\alpha = 15^\circ$



ELETH II

Lame circolari per macchine portatili
Lames circulaires pour machines portatives
TCT circular saw blades for portable machines
Cuchillas circulares para máquinas portátiles

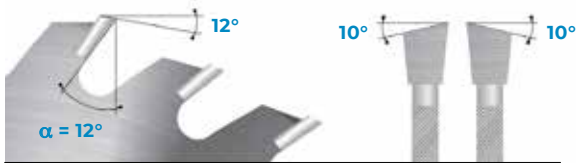

Taglio lungo e trasverso vena di legni duri, teneri e compensati. Dentatura alternata.



Coupe longue et transversale de bois durs, tendres et contre-plaqué. Denture alternée.



Lengthwise and cross grain cut of soft and hard woods, chipboard panels. Alternate teeth.



Corte longitudinal y transversal por vena de maderas blandas y duras, paneles de conglomerado. Diente alterno.

	D mm	B/b mm	d mm	Z	€
LC1504002	150	2,5 - 1,6	20	40	37,00
LC1604001	160	2,5 - 1,6	20	40	37,00
LC1604002	160	2,5 - 1,6	30	40	37,00
LC1654001	165	2,5 - 1,6	20	40	39,00
LC1654002	165	2,5 - 1,6	30	40	39,00
LC1704001	170	2,5 - 1,6	30	40	39,00
LC1804001	180	2,5 - 1,6	20	40	39,00
LC1804002	180	2,5 - 1,6	30	40	39,00
LC1844001	184	2,5 - 1,6	20	40	39,00
LC1844002	184	2,5 - 1,6	30	40	39,00
LC1904001	190	2,5 - 1,6	20	40	39,00
LC1904002	190	2,5 - 1,6	30	40	39,00
LC2004807	200	2,8 - 1,8	30	48	44,00
LC2104802	210	2,8 - 1,8	30	48	47,00
LC2164812	216	2,8 - 1,8	30	48	47,00
LC2204802	220	2,8 - 1,8	30	48	47,00
LC2304801	230	2,8 - 1,8	30	48	49,00
LC2354801	235	2,8 - 1,8	30	48	49,00
LC2404801	240	2,8 - 1,8	30	48	49,00

α = 12°



GAMMA I

Taglio trasverso vena
 Coupe transversale
 TCT circular saw crosscut
 Corte transversal por vena

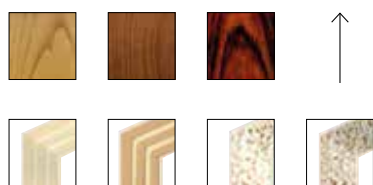

	D mm	B/b mm	d	Z	€
LC1504806	150	3,2 - 2,2	30	48	43,00
LC1805602	180	3,2 - 2,2	30	56	55,00
LC2006406	200	3,2 - 2,2	30	64	58,00
LC2508001	250	3,2 - 2,2	30	80	68,00
LC2808001	280	3,2 - 2,2	30	80	76,00
LC3009605	300	3,2 - 2,2	30	96	80,00
LC3059601	305	3,2 - 2,2	30	96	85,00
LC35010801	350	3,5 - 2,5	30	108	96,00
LC40012003	400	3,8 - 2,8	30	120	117,00

Fori di trascinamento - Trous d'entrainement
 Pinholes - Agujeros de arrastre

da D Ø 250 a D Ø 350 = 2/7/42 + 2/9/46,35 + 2/10/60
 D Ø 400 = 2/10/60

α = 10°



Progettate per tagliare legni duri, esotici, compensati, faesite, pannelli truciolari, multistrati, pannelli laminati da un solo lato e Formica. Finitura di alto livello per il legno, molto buona per agglomerati e multistrato e media per laminati e Formica. Dentatura alternata.



Coupe transversale de: bois tendres, bois durs, bois exotiques, contreplaqués, panneaux de fibres, panneaux de particules, multiplis, panneaux stratifiés simple face, Formica. Finition de haut niveau pour le bois, beaucoup de bonne pour agglomérations et multicouches et moyenne pour laminés et Formica. Denture alternée.



These blades are specifically designed for the cross grain cut of soft, hard, exotic woods, plywood, faesite, chipboard panels, multi-layer, panels laminated only on one side, Formica. High level of finishing for wood, very good for agglomerates and multi-layer and medium level for laminates and Formica. Alternate teeth.



Corte transversal por vena de: maderas duras, exóticas, compensados, madera sintética, conglomerados, multiestratos, paneles laminados de un solo lado, Formica. Terminación de nivel alto para madera, muy buena para conglomerados y paquetes y media por laminados y Formica. Diente alterno.



GAMMA II

Taglio lungo e trasverso vena
Coupe longitudinale et transversale
TCT circular saw lengthwise and crosscut
Corte longitudinal y transversal por vena

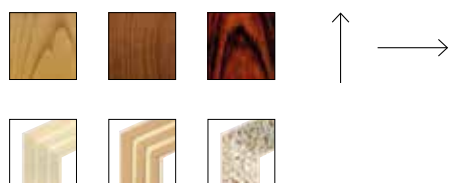

	D mm	B/b mm	d mm	Z	€
LC2506001	250	3,2 - 2,2	30	60	60,00
LC2806401	280	3,2 - 2,2	30	64	66,00
LC3007201	300	3,2 - 2,2	30	72	68,00
LC3057201	305	3,2 - 2,2	30	72	75,00
LC3508404	350	3,5 - 2,5	30	84	85,00
LC4009604	400	3,8 - 2,8	30	96	107,00

Fori di trascinamento - Trous d'entrainement
Pinholes - Agujeros de arrastre

da D Ø 250 a D Ø 350 = 2/7/42 + 2/9/46,35 + 2/10/60
D Ø 400 = 2/10/60

$\alpha = 10^\circ$



Lame progettate per ottenere un taglio lungo e trasverso vena per legni duri, esotici, compensati, faesite, pannelli truciolari e multistrati. Garantisce un'ottima finitura per il legno, buona per gli agglomerati e media per i multistrati. Dentatura alternata.



Coupe longitudinale et transversale de: bois tendres, bois durs, bois exotiques, contreplaqués, panneaux de fibres, panneaux de particules, multiplis. Est assurée une finition excellente pour le bois, bonne pour les agglomérations et moyenne pour les multi-niveau. Denture alternée.



Blades designed for the lengthwise and cross-grain cut of soft, hard, exotic woods, plywood, chipboard panels, multi-layer. It guarantees a perfect finishing for wood, good level finishing for agglomerates and medium level for multi-layer. Alternate teeth.



Corte longitudinal y transversal por vena de: maderas duras, exóticas, compensados, madera sintética, paneles de compensados, multiestratos. Terminación optimal para la madera, buena para conglomerados y media para paquetes. Diente alterno.



GAMMA III

Taglio lungo e trasverso vena
 Coupe longitudinale et transversale
 TCT circular saw Lengthwise and crossgrain cut
 Corte longitudinal y transversal por vena



	D mm	B/b mm	d mm	Z	€
LC2504003	250	3,2 - 2,2	30	40	52,00
LC2504802	250	3,2 - 2,2	30	48	54,00
LC3004802	300	3,2 - 2,2	30	48	60,00
LC3006006	300	3,2 - 2,2	30	60	64,00
LC3505403	350	3,5 - 2,5	30	54	71,00
LC3507201	350	3,5 - 2,5	30	72	77,00
LC4006401	400	3,8 - 2,8	30	64	93,00
LC4008001	400	3,8 - 2,8	30	80	100,00
LC4507201	450	4,0 - 2,8	30	72	152,00
LC5007202	500	4,0 - 2,8	30	72	176,00
LC5506005	550	4,0 - 2,8	30	60	165,00
LC6007201	600	4,0 - 2,8	30	72	192,00

Fori di trascinamento - Trous d'entrainement
 Pinholes - Agujeros de arrastre

da D Ø 250 a D Ø 350 = 2/7/42 + 2/9/46,35 + 2/10/60

da D Ø 400 a D Ø 600 = 2/10/60

α = da 10° a 12°



Ideale per tagli lunghi e trasversi su legni duri e teneri, compensati, faesite e pannelli truciolari. Garantisce una buona finitura per il legno e media per gli agglomerati. Dente alternato.



Coupe longitudinale et transversale de: bois tendres et bois durs, contreplaqués, panneaux de fibres et panneaux de particules. Est assurée une bonne finition pour le bois et moyenne pour les agglomérations. Denture alternée.



These blades are ideal for lengthwise and cross-grain cutting of soft and hard woods, plywood, faesite and chipboard panels. It guarantees a good finishing for wood and medium level for agglomerates. Alternate teeth.



Corte longitudinal y transversal por vena de maderas blandas y duras, compensados, madera sintética, paneles de conglomerado. Buena terminación para la madera y media para los conglomerados. Diente alterno.



GAMMA IV

Taglio lungo vena

Coupe longitudinale

TCT circular saw lengthwise grain cut

Corte longitudinal



	D mm	B/b mm	d mm	Z	€
LC2502401	250	3,2 - 2,2	30	24	48,00
LC3002406	300	3,2 - 2,2	30	24	50,00
LC3003601	300	3,2 - 2,2	30	36	55,00
LC3502802	350	3,5 - 2,5	30	28	67,00
LC3504206	350	3,5 - 2,5	30	42	69,00
LC4003202	400	3,8 - 2,8	30	32	79,00
LC4004801	400	3,8 - 2,8	30	48	86,00
LC4503602	450	4,0 - 2,8	30	36	110,00
LC4505404	450	4,0 - 2,8	30	54	128,00
LC5004003	500	4,0 - 2,8	30	40	130,00
LC5006002	500	4,0 - 2,8	30	60	152,00
LC5504401	550	4,0 - 2,8	30	44	147,00
LC6004804	600	4,0 - 2,8	30	48	158,00

Fori di trascinamento - Trous d'entrainement

Pinholes - Agujeros de arrastre

da D Ø 250 a D Ø 350 = 2/7/42 + 2/9/46,35 + 2/10/60

da D Ø 400 a D Ø 600 = 2/10/60

α = da 18° a 20°



Ideali per tagli lunghi su legni teneri e duri.
Finitura media. Dente alternato.



Idéal pour coupes longues sur bois tendres et durs.
Finition moyenne. Denture alternée.



This blade is ideal for lengthwise grain cutting
of soft and hard woods, the finish level is medium.
Alternate teeth.



Corte longitudinal de maderas blandas y duras.
Terminación media. Diente alterno.



INDUS



Dentatura *alternata*



Denture *alternée*

Alternate *toothing*



Dentado *alternado*





  Lame ad alto rendimento. HW resistente all'usura con alto contenuto di cromo (**KCr05**). Ideali per il taglio di pannelli truciolari, multistrato, laminati monolato. Ottima resistenza all'usura e grado di finitura elevato.

  HW spécial à haute teneur de chrome (**KCr05**), résistant à l'usure, rendement élevé. Coupe de panneaux d'aggloméré, multiplis, stratifiés simple face. Niveau de finition élevé. Excellente résistance à l'usure.

INDUS PLUS

  Lame ad alto rendimento. HW maggiormente resistente all'usura (**KCr05 Plus**) per più alte prestazioni. Ideali per il taglio di pannelli truciolari, multistrato, laminati monolato.

  HW spécial à haute teneur de chrome (**KCr05 Plus**), plus résistant à l'usure, rendement élevé. Coupe de panneaux d'aggloméré, multiplis, stratifiés simple face. Niveau de finition élevé.

 High performance blades. TCT resistant to strain with high content of chrome (**KCr05 Plus**) for higher levels of performance. Ideal for the cutting of chipboard panels, multi-layer, laminates on one side. High degree of finish. It has an excellent resistance to wear.

 Cuchillas de alto rendimiento. HW resistente al desgaste (**KCr05 Plus**) para rendimiento superior. Ideales para el corte de paneles de conglomerado, multiestrato, laminados de un solo lado.

	D mm	B/b mm	d mm	Z	€
LC2006404	200	3,2 - 2,2	30	64	63,00
LC2506008	250	3,2 - 2,2	30	60	65,00
LC2508007	250	3,2 - 2,2	30	80	74,00
LC3007207	300	3,2 - 2,2	30	72	74,00
LC3009606	300	3,2 - 2,2	30	96	87,00
LC3508407	350	3,5 - 2,5	30	84	93,00
LC35010808	350	3,5 - 2,5	30	108	104,00

Fori di trascinamento - Trous d'entraînement

Pinholes - Agujeros de arrastre

da D Ø 250 a D Ø 350 = 2/7/42 + 2/9/46,35 + 2/10/60

$\alpha = 10^\circ$

 High performance blades. TCT resistant to strain with high content of chrome (**KCr05**). Ideal for the cutting of chipboard panels, multi-layer, laminates on one side. High degree of finish. It has an excellent resistance to wear.

 HW especial con alto contenido de cromo (**KCr05**), alto rendimiento. Corte de paneles de conglomerado, multiestrato, laminados de un solo lado. Alto nivel de terminación. Resistencia excelente al desgaste.

	D mm	B/b mm	d mm	Z	€
LC2006404PA	200	3,2 - 2,2	30	64	69,00
LC2506008PA	250	3,2 - 2,2	30	60	71,00
LC2508007PA	250	3,2 - 2,2	30	80	81,00
LC3007207PA	300	3,2 - 2,2	30	72	81,00
LC3009606PA	300	3,2 - 2,2	30	96	95,00
LC3508407PA	350	3,5 - 2,5	30	84	102,00
LC35010808PA	350	3,5 - 2,5	30	108	114,00

Fori di trascinamento - Trous d'entraînement

Pinholes - Agujeros de arrastre



da D Ø 250 a D Ø 350 = 2/7/42 + 2/9/46,35 + 2/10/60

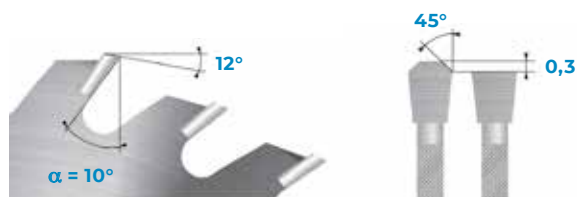

$\alpha = 10^\circ$

INDUS



Dentatura trapezio-piana
Denture trapézoïdale-plate
Trapezoidal-flat tooththing
Diente recto y trapezoidal





   Lame ad alto rendimento. HW resistente all'usura con alto contenuto di cromo (**KCr05**). Ideali per il taglio di materiali abrasivi, melaminici e per tutte le applicazioni a rischio di scheggiatura. In abbinamento con lama incisore consentono il taglio di pannelli bilaminati con ottima finitura. Adatte al taglio di PVC.

  HW spécial à haute teneur de chrome (**KCr05**), haut rendement. Coupe de matériaux abrasifs, mélamines et similaires, à haut risque d'éclat. Associée à une lame à graver, coupe de panneaux stratifiés double face avec excellente finition. Excellente résistance à l'usure. Indiquées à la coupe de PVC.

INDUS PLUS

   Lame ad alto rendimento. HW maggiormente resistente all'usura (**KCr05 Plus**) per più alte prestazioni. Ideali per il taglio di materiali abrasivi, melaminici e per tutte le applicazioni a rischio di scheggiatura. In abbinamento con lama incisore consentono il taglio di pannelli bilaminati con ottima finitura. Adatte al taglio di PVC.

  HW spécial à haute teneur de chrome (**KCr05 Plus**), plus résistant à l'usure, haut rendement. Coupe de matériaux abrasifs, mélamines et similaires, à haut risque d'éclat. Associée à une lame à graver, coupe de panneaux stratifiés double face avec excellente finition. Indiquées à la coupe de PVC.

 High performance blades. TCT resistant to strain with high content of chrome (**KCr05 Plus**) for higher levels of performance. This type of blade is perfect for cutting abrasive materials, melaminic and MDF there is a real risk of splintering. Can be used for the cutting of PVC.

 Cuchillas de alto rendimiento. HW resistente al desgaste (**KCr05 Plus**) para rendimiento superior. Corte de materiales abrasivos, melamínicos y similares, con especial

	D mm	B/b mm	d mm	Z	€
LC2006405	200	3,2 - 2,2	30	64	66,00
LC2506007	250	3,2 - 2,2	30	60	68,00
LC2508004	250	3,2 - 2,2	30	80	78,00
LC3007206	300	3,2 - 2,2	30	72	78,00
LC3009603	300	3,2 - 2,2	30	96	91,00
LC3508403	350	3,5 - 2,5	30	84	98,00
LC35010807	350	3,5 - 2,5	30	108	109,00

Fori di trascinamento - Trous d'entrainement
Pinholes - Agujeros de arrastre

da D Ø 250 a D Ø 350 = 2/7/42 + 2/9/46,35 + 2/10/60

$\alpha = 10^\circ$

 High performance blades. TCT resistant to strain with high content of chrome (**KCr05**). This type of blade is perfect for cutting abrasive materials, melaminic and MDF there is a real risk of splintering. Perfect for the cutting of PVC.

 HW especial con alto contenido de cromo (**KCr05**), alto rendimiento. Corte de materiales abrasivos, melamínicos y similares, con especial riesgo de astillado. Combinada con cuchilla grabadora, corte de paneles doble laminado con una terminación óptima. Resistencia excelente al desgaste. Aptas para el corte de PVC.

	D mm	B/b mm	d mm	Z	€
LC2006405P	200	3,2 - 2,2	30	64	73,00
LC2506007P	250	3,2 - 2,2	30	60	75,00
LC2508004P	250	3,2 - 2,2	30	80	86,00
LC3007206P	300	3,2 - 2,2	30	72	86,00
LC3009603P	300	3,2 - 2,2	30	96	100,00
LC3508403P	350	3,5 - 2,5	30	84	108,00
LC35010807P	350	3,5 - 2,5	30	108	120,00

Fori di trascinamento - Trous d'entrainement
Pinholes - Agujeros de arrastre

da D Ø 250 a D Ø 350 = 2/7/42 + 2/9/46,35 + 2/10/60

$\alpha = 10^\circ$

riesgo de astillado. Combinada con cuchilla grabadora, corte de paneles doble laminado con una terminación óptima. Resistencia excelente al desgaste. Aptas para el corte de PVC.

Lame per multilame a più rasanti - **Grandi dimensioni**
 Lames pour multilames plusieurs racleurs - **Grandes dimensions**
 TCT ripping saw blades with wipers - **Large sizes**
 Cuchillas multiples con varios raspadores - **Gran tamaño**



Lame circolari a più rasanti, perfette per tagli multipli di legni umidi e difficili da gestire. I rasanti inseriti nel corpo della lama impediscono la chiusura del taglio. Dentatura piatta.



Lames circulaires à plusieurs racleurs. Conseillées pour les coupes multiples de bois humides et nerveux. Les racleurs intégrées à la structure de la lame empêchent la fermeture de la fente. Denture plate.



Multiple rip saws suitable for cutting soft and hard woods. The wiper inserted in the body of the blade prevent the closure of the cut. Flat teeth.



Cuchillas circulares con varios raspadores. Grandes dimensiones. Indicadas para cortes múltiples de maderas húmedas o enervadas. Los niveladores introducidos en el cuerpo de la cuchilla impiden el cierre del corte. Diente plano.

D mm	B/b mm	Z+R	P/t mm	€
450	4,4 - 3,0	24 + 4	130	150,00
460	4,4 - 3,0	24 + 4	130	175,00
470	4,4 - 3,0	24 + 4	130	175,00
480	4,4 - 3,0	24 + 4	130	175,00
500	4,4 - 3,0	24 + 4	150	175,00
510	4,6 - 3,2	24 + 6	150	220,00
520	4,6 - 3,2	24 + 6	150	220,00
530	4,6 - 3,2	24 + 6	150	220,00
550	4,6 - 3,2	24 + 6	160	220,00
560	5,0 - 3,5	24 + 6	160	280,00
570	5,0 - 3,5	24 + 6	160	280,00
580	5,0 - 3,5	24 + 6	160	280,00
600	5,0 - 3,5	28 + 6	170	280,00
610	5,0 - 3,5	28 + 6	170	350,00
630	5,5 - 4,0	28 + 6	170	350,00
700	5,5 - 4,0	32 + 6	200	350,00

P/t mm: Prof. max di taglio - Prof. max de coupe
 Max. cutting depth - Prof. máx. de corte

d mm: Foro a richiesta - Alesage à spécifier
 Bore on specification - Agujeros según pedido

$\alpha = 20^\circ$

- A richiesta tutti i tipi possono avere il limitatore di truciolo.
- Sur demande, tous les types peuvent recevoir un limiteur de copeaux.
- On request all types can have a chip limiter.
- Sobre pedido, todos los tipos pueden tener un limitador de virutas.



MIZAR CON DUE RASANTI

Lame per multilame a due rasanti
Lames pour multilames à deux raclours
TCT ripping saw blades with two wipers
Cuchillas multiples con dos raspadores



	D mm	B/b mm	d mm	Z+R	P/t mm	€
LC2R2501801	250	3,2 - 2,2	70	18+2	50	53,00
LC2R2501802	250	3,2 - 2,2	80	18+2	50	53,00
LC2R2802001	280	3,2 - 2,2	70	20+2	60	58,00
LC2R2802002	280	3,2 - 2,2	80	20+2	60	58,00
LC2R3002009	300	3,2 - 2,2	70	20+2	70	60,00
LC2R3002010	300	3,2 - 2,2	80	20+2	70	60,00
LC2R3502401	350	3,5 - 2,5	70	24+2	80	70,00
LC2R3502402	350	3,5 - 2,5	80	24+2	80	70,00

P/t mm: Prof. max di taglio - Prof. max de coupe
Max. cutting depth - Prof. máx. de corte

$\alpha = 20^\circ$



Modello a due rasanti indicato per macchine mono-albero o bi-albero, con minime altezze di taglio. Lame perfette per legni umidi e difficili da gestire, i due rasanti nel corpo della lama impediscono la chiusura del taglio. Dentatura alternata.



Conseillées pour machines mono-arbre ou bi-arbre à hauteurs de coupe réduites. Pour les bois humides et nerveux. Les deux raclours intégrées à la structure de la lame empêchent la fermeture de la fente. Denture alternée.



TCT ripping saw blades with two wipers. This range of blades is the ideal for multiple cuts with single shaft or twin shaft machines for processing humid or nery wood types. The wiper-slots inserted in the body of the blade prevent the closure of the cut. Alternated teeth.



Indicadas para las máquinas mono-eje o bi-eje, con alturas de corte mínimas. Para maderas húmedas o enervadas. Los dos raspadores introducidos en el cuerpo de la cuchilla impiden el cierre del corte. Diente alterno.

- A richiesta tutti i tipi possono avere il limitatore di truciolo.
- Sur demande, tous les types peuvent recevoir un limiteur de copeaux.
- On request all types can have a chip limiter.
- Sobre pedido, todos los tipos pueden tener un limitador de virutas.





MIZAR A PIÙ RASANTI

Lame per multilame a più rasanti
 Lames pour multilames plusieurs racleurs
 TCT ripping saw blades with wipers
 Cuchillas multiples con varios raspadores



 Lame circolari a più rasanti per tagli multipli con macchine mono o bi-albero. Perfette per legni umidi e difficili da gestire. I rasanti inseriti nel corpo della lama impediscono la chiusura del taglio. Dentatura alternata.

 Lames circulaires à plusieurs racleurs. Conseillées pour les coupes multiples sur machines mono ou bi-arbre, de bois humides et nerveux. Les racleurs intégrées à la structure de la lame empêchent la fermeture de la fente. Denture alternée.

 Multiple rip saw suitable for cutting soft and hard woods. Indicated for multiripping machines with single shaft or twin shaft. The wiper inserted in the body of the blade prevent the closure of the cut. Alternated teeth.

 Cuchillas circulares con varios raspadores. Especialmente indicadas para cortes múltiples con máquinas mono-eje o bi-eje de maderas húmedas o nervadas. Los raspadores introducidos en el cuerpo de la cuchilla impiden el cierre del corte. Diente alterno.

- A richiesta tutti i tipi possono avere il limitatore di truciolo.
- Sur demande, tous les types peuvent recevoir un limiteur de copeaux.
- On request all types can have a chip limiter.
- Sobre pedido, todos los tipos pueden tener un limitador de virutas.



	D mm	B/b mm	d mm	Z+R	P/t mm	€
LC4R2502002	250	2,5 - 1,6	70	20+4	40	60,00
LC4R2502003	250	2,5 - 1,6	80	20+4	40	60,00
LC4R2502005	250	3,2 - 2,2	70	20+4	50	58,00
LC4R2502006	250	3,2 - 2,2	80	20+4	50	58,00
LC4R2802402	280	2,5 - 1,6	70	24+4	50	66,00
LC4R2802403	280	2,5 - 1,6	80	24+4	50	66,00
LC4R2802405	280	3,2 - 2,2	70	24+4	60	63,00
LC4R2802406	280	3,2 - 2,2	80	24+4	60	63,00
LC4R3002405	300	2,5 - 1,6	70	24+4	60	68,00
LC4R3002406	300	2,5 - 1,6	80	24+4	60	68,00
LC4R3002009	300	3,2 - 2,2	70	20+4	70	64,00
LC4R3002010	300	3,2 - 2,2	80	20+4	70	64,00
LC4R3002408	300	3,2 - 2,2	70	24+4	70	66,00
LC4R3002409	300	3,2 - 2,2	80	24+4	70	66,00
LC4R3202404	320	3,2 - 2,2	70	24+4	70	69,00
LC4R3202405	320	3,2 - 2,2	80	24+4	70	69,00

	D mm	B/b mm	d mm	Z+R	P/t mm	€
LC4R3502416	350	3,2 - 2,2	70	24+4	70	69,00
LC4R3502417	350	3,2 - 2,2	80	24+4	70	69,00
LC4R3502418	350	3,5 - 2,5	70	24+4	90	77,00
LC4R3502419	350	3,5 - 2,5	80	24+4	90	77,00
LC4R3502805	350	3,5 - 2,5	70	28+4	90	80,00
LC4R3502806	350	3,5 - 2,5	80	28+4	90	80,00
LC4R3502403	350	4,2 - 2,8	70	24+4	90	98,00
LC4R3802405	380	4,0 - 2,8	70	24+4	110	113,00
LC4R3802406	380	4,0 - 2,8	80	24+4	110	113,00
LC4R3802801	380	4,0 - 2,8	70	28+4	110	118,00
LC4R3802802	380	4,0 - 2,8	80	28+4	110	118,00
LC4R4002410	400	4,2 - 2,8	70	24+4	120	115,00
LC4R4002411	400	4,2 - 2,8	80	24+4	120	115,00
LC4R4002810	400	4,2 - 2,8	70	28+4	120	120,00
LC4R4002811	400	4,2 - 2,8	80	28+4	120	120,00

P/t mm: Prof. max di taglio - Prof. max de coupe
Max. cutting depth - Prof. máx. de corte

$\alpha = 20^\circ$

- A richiesta le lame possono essere fornite con un particolare rivestimento antiossidante (black coating) che migliora l'espulsione dei trucioli.
- Sur demande les lames peuvent être fournies avec un revêtement spécial antiossidante (black coating) qu'il améliore l'expulsion des copeaux.

- On request the blades can be supplied with a particular antioxidant coating (black coating), which improves the expulsion of chips.
- Sobre pedido, las cuchillas pueden ser provistas con revestimiento antioxidante (black coating) para mejorar la expulsión de las virutas.



Lame a spessore sottile

Lames minces

Thin TCT circular saw blades

Cuchillas de espesor fino

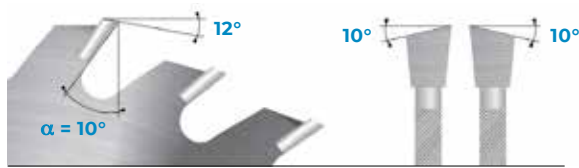

Lame a spessore ridotto, per massima precisione di taglio, impiegate su segatrici circolari a banco e troncatrici. Ideate per il taglio lungo e controvena di legni pregiati, laminati plastici, cornici. Alto grado di finitura. Affilatura alternata.



Lames circulaires à très faible épaisseur, pour meilleure précision de la coupe. Conseillées pour la coupe des bois rares, des stratifiés plastiques et encadrements en général, avec niveau de finition élevé. Denture alternée.

	D mm	B/b mm	d mm	Z	€
LC2006401	200	2,2 - 1,6	30	64	61,00
LC2506002	250	2,4 - 1,8	30	60	63,00
LC2508008	250	2,4 - 1,8	30	80	72,00
LC3007202	300	2,4 - 1,8	30	72	72,00
LC3009610	300	2,4 - 1,8	30	96	84,00
LC35010810	350	3,0 - 2,2	30	108	100,00

Fori di trascinamento - Trous d'entraînement

Pinholes - Agujeros de arrastre

da D Ø 250 a D Ø 350 = 2/7/42 + 2/9/46,35 + 2/10/60

$\alpha = 10^\circ$



Thin TCT circular saw blades to achieve the maximum cut precision, they are specifically designed for the cutting of valuable woods, plastic laminates and frames in general. Alternated teeth.



Cuchillas de espesor reducido, para la máxima precisión de corte. Utilizadas en sierras circulares de banco y cortadoras de trefilados. Por el corte longitudinal y contra a la vena de maderas valiosas, laminados plásticos y marcos. Alto grado de terminación. Diente alterno.

SHARP

Lame con dente concavo - Angolo di taglio positivo
 Lames denture gouge - Angle de coupe positif
 Hollow round - Rake angle positive
 Cuchillas con dientes cóncavos - Ángulo de corte positivo



	D mm	B/b mm	d mm	Z	€
LC2204203	220	3,2 - 2,2	30	42	95,00
LC2504806	250	3,2 - 2,2	30	48	100,00
LC3006007	303	3,2 - 2,2	30	60	120,00
LC3507210	350	3,5 - 2,5	30	72	150,00

Fori di trascinamento - Trous d'entrainement
 Pinholes - Agujeros de arrastre

da D Ø 220 a D Ø 350 = 2/7/42 + 2/9/46,35 + 2/10/60

$\alpha = 10^\circ$



Lame adatte per tagliare e sezionare con precisione materiali abrasivi, melaminici, pannelli bilaminati, Formica e nobilitati con finiture di grado elevato. Impiegate su macchine verticali, senza l'ausilio della lama incisore.



Pour toutes les machines verticales sans lame à rainer. Coupe et sectionnement de précision de matériaux abrasifs, mélaminés et similaires, panneaux stratifiés double face, Formica et placages. Haut niveau de finition.



TCT circular saw blades with hollow round teeth, the ideal for the precision cutting and sectioning of abrasive materials, melaminic and similar materials, bi-laminates, Formica. The degree of finish is high. Employed on vertical machinery, without scoring saw.



Cuchillas para cortar y seccionar con precisión materiales abrasivos, melamínicos, paneles doble laminados, Formica y ennoblecidos con terminación de alto nivel. Empleadas en maquinas verticales sin cuchilla grabadora.



Lame per sezionatrici con incisore

Lames pour scies à panneaux avec l'emploi de l'inciseur

TCT panel sizing saw blades with scoring

Cuchillas para seccionadores con grabador

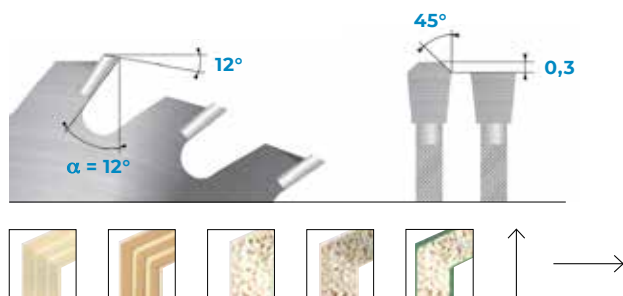

Lame circolari a forte spessore. HW ad alto contenuto di cromo (**KCr05**) con grande resistenza all'usura e grado di finitura elevato. A richiesta, le lame possono essere fornite con HW maggiormente resistente all'usura (**KCr05 Plus**).

La forma trapezio-piana del dente, garantisce una migliore sezionatura e squadratura di compensati, pannelli truciolari, multistrato, MDF, pannelli placcati e controplaccati, materiali abrasivi, melaminici ad alto rischio di scheggiatura.



Lames de scie circulaires de mise à format pour scies à panneaux. HW avec un haut contenu de chrome (**KCr05**), avec grande résistance à l'usure et degré de finition élevés. Sur demande les lames peuvent être fournies avec HW plus fort (**KCr05 Plus**). Sectionnement et cadrage de précision de contreplaqués, panneaux de particules, multiplis, MDF, panneaux plaqués et contreplaqués, matériaux abrasifs, mélamines et similaire à haut risque d'éclat. Niveau de finition élevé, excellente résistance à l'usure. Denture trapézoïdale-plate.



Large thickness circular saw blades with special TCT high chrome content (**KCr05**). On request, for higher levels of performance, with high content of chrome (**KCr05 Plus**). The blades is specifically designed for the precision sectioning and squaring of plywood, chipboard panels, multi-layer, MDF, plated and counter-plated panels, abrasive materials and melaminic and similar materials with the risk of splintering. Trapezoidal-flat teeth.



Cuchillas circulares a grande espesor. HW especial con alto contenido de cromo (**KCr05**), excelente resistencia al desgaste y alto nivel de terminación. Sobre pedido, las cuchillas pueden ser provistas (**KCr05Plus**) para mejorar la resistencia al desgaste. Los dientes de forma trapezoidal-plana garantizan mejores seccionamiento y escudaría de compensados, conglomerados, multiestratos, MDF, paneles chapados y contrachapados, materiales abrasivos, melamínicos a riesgo de astillado.

	D mm	B / b mm	d mm	Z	Pinholes	€
LC3006030	300	4,4 / 3,2	30	60	COMBI 3	100,00
LC3006031	300	4,4 / 3,2	75	60	4/15/105	100,00
LC3006032	300	4,4 / 3,2	80	60	COMBI 5	100,00
LC3505440	350	4,4 / 3,2	30	54	COMBI 3	107,00
LC3505441	350	4,4 / 3,2	75	54	4/15/105	107,00
LC3505442	350	4,4 / 3,2	80	54	COMBI 5	107,00
LC3507243	350	4,4 / 3,2	30	72	COMBI 3	122,00
LC3507244	350	4,4 / 3,2	50	72	3/12,5/80	122,00
LC3507245	350	4,4 / 3,2	60	72	4/9/100	122,00
LC3507246	350	4,4 / 3,2	75	72	4/15/105	122,00
LC3507247	350	4,4 / 3,2	80	72	COMBI 5	122,00
LC3807290	380	4,8 / 3,5	60	72	COMBI 7	148,00
LC4006050	400	4,4 / 3,2	30	60	2/10/60	125,00
LC4006051	400	4,4 / 3,2	75	60	4/15/105	125,00
LC4006052	400	4,4 / 3,2	80	60	COMBI 5	125,00
LC4007253	400	4,4 / 3,2	30	72	2/10/60	135,00
LC4007254	400	4,4 / 3,2	60	72	COMBI 7	135,00
LC4007255	400	4,4 / 3,2	75	72	4/15/105	135,00
LC4007256	400	4,4 / 3,2	80	72	COMBI 5	135,00
LC4307260	430	4,4 / 3,2	75	72	4/15/105	150,00
LC4307261	430	4,4 / 3,2	80	72	COMBI 5	150,00
LC4507270	450	4,8 / 3,5	60	72	COMBI 7	160,00
LC4507271	450	4,8 / 3,5	80	72	COMBI 5	160,00
LC5007280	500	4,8 / 3,5	60	72	COMBI 7	175,00
LC5007281	500	4,8 / 3,5	80	72	COMBI 5	175,00

$\alpha = 12^\circ$

COMBI 3
PINHOLE
(mm)

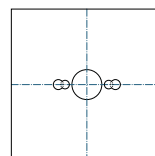

2/7/42
2/9/46,35
2/10/60

COMBI 5
PINHOLE
(mm)

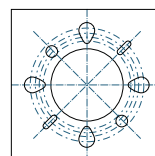

2/7/110
2/8,4/130
2/14/110
4/9/100
4/19/120

COMBI 7
PINHOLE
(mm)

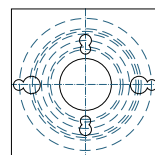

2/10/80
1/11/85
2/11/115
2/11/148
2/14/100
2/14/125
2/19/120

THYCO

Incisori conici

Inciseurs coniques

TCT conical scoring saw blades

Sierras circulares grabadores con diente cónico



Lame per sezionatrici, con l'albero dell'incisore regolabile in altezza, in funzione dello spessore di taglio, della lama sezionatrice. Adatte per il taglio di pannelli impiallacciati e laminati su due lati, MDF e truciolare.



Lames circulaires inciseuses, indiquées pour l'emploi sur des machines à sectionner automatique. Les tranchants coniques permettent de varier la largeur de coupe sur la base de la profondeur de l'incision. Appropriées pour la coupe de bilaminates et MDF.



Scoring circular saw blade for sectioning machines, with conical teeth. Suitable for the cutting of veneered panels laminated on two sides, MDF and chipboard.



Cuchillas para seccionadoras, con eje del grabador ajustable en altura, en función del espesor de corte, de la cuchilla seccionadora. Aptas para el corte de paneles contrachapados y laminados en dos lados, MDF y conglomerado.

	D mm	B mm	b mm	d mm	Z	Pinholes	€
LC1002010	100	3,1 / 4,3	2,2	20	20	-	47,00
LC1002011	100	3,1 / 4,3	2,2	22	20	-	47,00
LC1202410	120	3,1 / 4,3	2,2	20	24	-	49,00
LC1202411	120	3,1 / 4,3	2,2	22	24	-	49,00
LC1202412	120	3,4 / 4,6	2,2	20	24	-	51,00
LC1252420	125	3,1 / 4,3	2,2	20	24	-	49,00
LC1252421	125	3,1 / 4,3	2,2	22	24	-	49,00
LC1252422	125	3,4 / 4,6	2,2	20	24	-	51,00
LC1252423	125	4,3 / 5,5	3,2	20	24	-	54,00
LC1252424	125	4,3 / 5,5	3,2	45	24	-	54,00
LC1503611	150	4,3 / 5,5	3,2	45	36	-	77,00
LC1603610	160	4,3 / 5,5	3,2	45	36	3/11/70	84,00
LC1603611	160	4,3 / 5,5	3,2	55	36	3/7/66	84,00
LC1603612	160	4,7 / 6,0	3,5	55	36	3/7/66	91,00
LC1803610	180	4,3 / 5,5	3,2	20	36	-	98,00
LC1803611	180	4,3 / 5,5	3,2	30	36	-	98,00
LC1804412	180	4,3 / 5,5	3,2	50	44	3/12,5/80	105,00
LC1803613	180	4,7 / 6,0	3,5	45	36	-	102,00
LC1803614	180	5,0 / 6,2	3,5	55	36	-	104,00
LC2003610	200	4,3 / 5,5	3,2	20	36	-	100,00
LC2003611	200	4,3 / 5,5	3,2	45	36	-	100,00
LC2003612	200	4,3 / 5,5	3,2	65	36	2/9/100 +2/9/110	100,00
LC2003613	200	4,7 / 6,0	3,5	45	36	-	105,00
LC2154210	215	4,3 / 5,5	3,2	50	42	3/15/80	110,00

$\alpha = 10^\circ$



RIGEL

Lame per sezionatrici - Incisori doppi regolabili
 Lames pour scie à panneaux - Inciseurs doubles extensibles
 TCT blades for panel saws - Double scoring adjustable
 Cuchillas para seccionadores - Grabadores dobles ajustables



Lame indicate su macchine sezionatrici e adatte alla sezionatura del rivestimento di pannelli bilaminati e MDF. Dentatura piatta.



Lames circulaires doubles, équipées avec des bagues intercalaires pour régler la largeur de l'incision. Indiquées pour l'emploi sur des particulières machines à sectionner. Denture plate.

	D mm	B mm	b mm	d mm	Z	€
LC1002001	100	2,8 / 3,6	2,1	20	10+10	72,00
LC1002002	100	2,8 / 3,6	2,1	22	10+10	72,00
LC1202407	120	2,8 / 3,6	2,1	20	12+12	75,00
LC1202408	120	2,8 / 3,6	2,1	22	12+12	75,00
LC1252403	125	2,8 / 3,6	2,1	20	12+12	75,00
LC1252404	125	2,8 / 3,6	2,1	22	12+12	75,00

$\alpha = 10^\circ$



Suitable blades for sectioning machines and proper for the sectioning of the covering of bi-laminate panels and MDF. Flat teeth.



Cuchillas indicadas para seccionadoras y aptas al seccionamiento del revestimiento de paneles laminados en dos lados y MDF. Diente plano.



LAME PER MACCHINE LAMELLO

Lama circolare per macchina "Lamello"

Lame speciale pour machine "Lamello"

TCT circular saw blades special for machine "Lamello"

Sierra especial para maquina "Lamello"

	D mm	B mm	b mm	d	Z	€
FRAI0001	100	3,97	3,0	22	8	55,00

$\alpha = 12^\circ$



Lame per incastri di ottima qualità su legni teneri e duri lungo vena e trasverso vena; su multistrato, truciolati, laminati e MDF. Dentatura piatta.



Lames à rainer, d'excellente qualité sur les bois tendres et durs. Conseillées sur panneaux stratifiés et MDF. Denture plate.



Blades for high quality rip-cut and cross-cut joints on hard and soft woods; plywood, chipboard, laminates and MDF. Flat teeth.



Cuchillas para encajes de calidad en maderas blandas y duras. Longitudinales y transversal por vena; para madera multicapa, conglomerados, laminados y MDF. Diente plano.



LAME A FORTE SPESSORE PER INCASTRI

Fraises à rainer | Grooving cutters | Fresas para ranurar



— Lame usate per eseguire canali a misura fissa. Taglio lungo e trasverso vena di legni duri, teneri, esotici e pannelli con rivestimento plastico. Dentatura piatta.

— Lames utilisées pour faire des canaux de taille fixe. Coupe longitudinale et transversale de bois durs et doux, bois exotiques et de panneaux avec revêtement plastique. Denture plate.

— Blades used to make fixed size channels. Rip-cutting and cross-cutting of hard, soft, exotic woods and plastic coated panels. Flat teeth.

— Cuchillas para efectuar canales de medida fija. Corte longitudinal y transversal por vena de maderas duras, blandas, exóticas y paneles con revestimiento plástico. Diente plano.

	D mm	B mm	d	Z	€
FRAI150R35	150	3,5 - 2,5	30	12	55,00
FRAI150R40	150	4,0 - 2,8	30	12	60,00
FRAI150R50	150	5,0 - 3,2	30	12	75,00
FRAI150R60	150	6,0 - 3,2	30	12	85,00
FRAI180R40	180	4,0 - 2,8	30	24	65,00
FRAI180R50	180	5,0 - 3,2	30	24	85,00
FRAI180R60	180	6,0 - 3,5	30	24	100,00
FRAI200R40	200	4,0 - 2,8	30	24	70,00
FRAI200R50	200	5,0 - 3,2	30	24	90,00

$\alpha = 20^\circ$



LAME AL CROMO VANADIO

Lame in acciaio senza HW

Lames en acier sans HW

Steel blades without TCT

Cuchillas en acero sin HW

— Lame in acciaio cromo-vanadio, tensionate, affilate e stradate: pronte all'uso. Forma del dente, NV (normale diritta).

— Scies circulaires au chrome-vanadium, tensionnés affûtées avoyées. Denture normale, NV.

— Circular saw blades vanadium-chromium tensionned, sharpened. Teeth form: NV.

— Cuchillas en acero cromo-vanadio, tensadas y afiladas: listas para ser usadas. Forma del diente, NV (normal recta).

	D mm	B mm	d	Z	€
LADF2006404	200	1,5	30	80	40,00
LADF2508002	250	1,5	30	80	43,00
LADF30010002	300	1,6	30	80	45,00
LADF35010004	350	1,8	30	80	52,00
LADF4009601	400	2,0	30	80	62,00
LADF4509601	450	2,5	30	80	85,00
LADF5009603	500	2,5	30	80	95,00
LADF5509601	550	2,6	30	80	120,00
LADF6005602	600	2,8	30	80	135,00



THOREX

Coltelli per pialla
Couteaux à raboter
Planing knives
Cuchillas para cepilladora

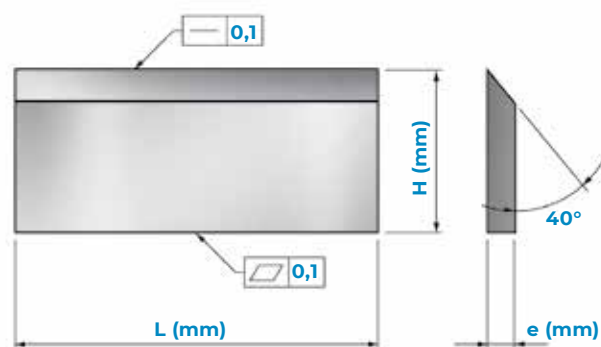

	h mm	€/m
Cr 13% - ART. FEDS	25 / 30 / 35	45,00
HSS 18% - ART. FEHS	25 / 30 / 35	65,00



Cr 13% Per legni teneri umidi
HSS 18% Per legni teneri essiccati e legni duri umidi.



Cr 13% Proper for wet tender woods
HSS 18% Proper for dried tender woods and damp hard woods.



Cr 13% Pour bois humide tendres
HSS 18% Pour bois tendres desséchés et bois durs humide.



Cr 13% Para maderas blandas húmedas
HSS 18% Para maderas blandas secadas y maderas duras húmedas.

ANELLI DI RIDUZIONE

Bagues de reduction
Reduction rings
Anillos para reducción



	D mm	d mm	€
CIRC20127	20	12,7	8,00
CIRC2016	20	16	8,00
CIRC2520	25	20	8,00
CIRC3016	30	16	8,00
CIRC3020	30	20	8,00
CIRC3022	30	22	8,00
CIRC3025	30	25	8,00
CIRC30254	30	25,4	8,00
CIRC3220	32	20	8,00
CIRC3225	32	25	8,00
CIRC3230	32	30	8,00
CIRC3520	35	20	8,00
CIRC3525	35	25	8,00
CIRC3530	35	30	8,00
CIRC3532	35	32	8,00



TAGLIO METALLO

COUPE METAL

METAL CUTTING

CORTE METAL

ALGOR

Lame circolari per alluminio e leghe leggere
Lames circulaires pour aluminium et ligues légères
TCT circular saws for aluminum and light alloys
Cuchillas circulares para aluminio y aleaciones ligeras



Lame per il taglio di profili in alluminio e sue leghe, zinco, rame, ottone e bronzo. Dente trapezoidale Positivo consigliato su macchine automatiche.



Lames indiquées pour la coupe de profils en aluminium et alliages en métal non ferreux. Denture trapézoïdale-plate Positive pour machines automatiques.



These blades are ideal for cutting aluminium profiles and solids and non/ferrous alloys. Trapezoidal flat Positive tooth for automatic machines.



Cuchillas para el corte de perfiles en aluminio y sus aleaciones, cinc, cobre, latón y bronce. Dientes de forma trapezoidal Positiva. Aconsejado para maquinas automáticas.

Pos.	D mm	B/b mm	d mm	Z	€
LC2006002	200	3,0-2,0	30	60	63,00
LC2166007	216	3,0-2,0	30	60	64,00
LC2506004	250	3,2-2,2	30	60	65,00
LC2506012	250	3,2-2,2	32	60	65,00
LC2508003	250	3,2-2,2	30	80	74,00
LC2508016	250	3,2-2,2	32	80	74,00
LC3007204	300	3,2-2,4	30	72	74,00
LC3007222	300	3,2-2,4	32	72	74,00
LC3008403	300	3,2-2,4	30	84	80,00
LC3008409	300	3,2-2,4	32	84	80,00
LC3009602	300	3,2-2,4	30	96	87,00
LC3009618	300	3,2-2,4	32	96	87,00
LC3508401	350	3,4-2,8	30	84	89,00
LC3508402	350	3,4-2,8	32	84	89,00
LC3509603	350	3,4-2,8	30	96	97,00
LC3509604	350	3,4-2,8	32	96	97,00
LC35010803	350	3,4-2,8	30	108	104,00
LC35010804	350	3,4-2,8	32	108	104,00
LC4009603	400	3,6-2,8	30	96	113,00
LC4009614	400	3,6-2,8	32	96	113,00
LC40012007	400	3,6-2,8	30	120	132,00
LC40012008	400	3,6-2,8	32	120	132,00
LC42010802	420	3,8-3,0	30	108	152,00
LC42010804	420	3,8-3,0	32	108	152,00
LC4509603	450	3,8-3,0	30	96	142,00
LC4509604	450	3,8-3,0	32	96	142,00
LC45010802	450	3,8-3,0	30	108	154,00
LC45010808	450	3,8-3,0	32	108	154,00
LC45012801	450	3,8-3,0	30	128	175,00
LC45012803	450	3,8-3,0	32	128	175,00
LC50012004	500	4,0-3,2	30	120	190,00
LC50012009	500	4,0-3,2	32	120	190,00
LC50014001	500	4,0-3,2	30	140	210,00
LC50014003	500	4,0-3,2	32	140	210,00
LC55013203	550	4,2-3,5	30	132	220,00
LC55013204	550	4,2-3,5	32	132	220,00
LC55014801	550	4,2-3,5	30	148	235,00
LC55014803	550	4,2-3,5	32	148	235,00
LC60014401	600	4,2-3,5	30	144	235,00
LC60014405	600	4,2-3,5	32	144	235,00
LC60015601	600	4,2-3,5	30	156	250,00
LC60015603	600	4,2-3,5	32	156	250,00

Fori di trascinamento - Trous d'entraînement
Pinholes - Agujeros de arrastre

d Ø 30 e d Ø 32 = 2/11/63

$\alpha = 5^\circ$

ALGOR

Lame circolari per alluminio e leghe leggere
Lames circulaires pour aluminium et ligues légères
TCT circular saws for aluminum and light alloys
Cuchillas circulares para aluminio y aleaciones ligeras



Lame per il taglio di profili in alluminio e sue leghe, zinco, rame, ottone e bronzo. Dente trapezoidale Negativo consigliato su macchine automatiche.



Lames indiquées pour la coupe de profils en aluminium et alliages en métal non ferreux. Denture trapézoïdale-plate Negative pour machines manuelles traditionnelles.



These blades are ideal for cutting aluminium profiles and non/ferrous alloys. Trapezoidal flat Negative tooth for manual machines.



Cuchillas para el corte de perfiles en aluminio y sus aleaciones, cinc, cobre, latón y bronce. Dientes de forma trapezoidal Negativa. Aconsejado para maquinas manuales.

Pos.	D mm	B/b mm	d mm	Z	€
LC2006001	200	3,0-2,0	30	60	63,00
LC2166006	216	3,0-2,0	30	60	64,00
LC2506003	250	3,2-2,2	30	60	65,00
LC2506005	250	3,2-2,2	32	60	65,00
LC2508002	250	3,2-2,2	30	80	74,00
LC2508006	250	3,2-2,2	32	80	74,00
LC3007203	300	3,2-2,4	30	72	74,00
LC3007223	300	3,2-2,4	32	72	74,00
LC3008407	300	3,2-2,4	30	84	80,00
LC3008402	300	3,2-2,4	32	84	80,00
LC3009604	300	3,2-2,4	30	96	87,00
LC3009609	300	3,2-2,4	32	96	87,00
LC3508405	350	3,4-2,8	30	84	89,00
LC3508406	350	3,4-2,8	32	84	89,00
LC3509601	350	3,4-2,8	30	96	97,00
LC3509602	350	3,4-2,8	32	96	97,00
LC35010805	350	3,4-2,8	30	108	104,00
LC35010802	350	3,4-2,8	32	108	104,00
LC4009601	400	3,6-2,8	30	96	113,00
LC4009602	400	3,6-2,8	32	96	113,00
LC40012001	400	3,6-2,8	30	120	132,00
LC40012002	400	3,6-2,8	32	120	132,00
LC42010801	420	3,8-3,0	30	108	152,00
LC42010805	420	3,8-3,0	32	108	152,00
LC4509601	450	3,8-3,0	30	96	142,00
LC4509602	450	3,8-3,0	32	96	142,00
LC45010803	450	3,8-3,0	30	108	154,00
LC45010805	450	3,8-3,0	32	108	154,00
LC45012802	450	3,8-3,0	30	128	175,00
LC45012804	450	3,8-3,0	32	128	175,00
LC50012003	500	4,0-3,2	30	120	190,00
LC50012010	500	4,0-3,2	32	120	190,00
LC50014002	500	4,0-3,2	30	140	210,00
LC50014004	500	4,0-3,2	32	140	210,00
LC55013201	550	4,2-3,5	30	132	220,00
LC55013205	550	4,2-3,5	32	132	220,00
LC55014802	550	4,2-3,5	30	148	235,00
LC55014804	550	4,2-3,5	32	148	235,00
LC60014404	600	4,2-3,5	30	144	235,00
LC60014406	600	4,2-3,5	32	144	235,00
LC60015602	600	4,2-3,5	30	156	250,00
LC60015604	600	4,2-3,5	32	156	250,00

Fori di trascinamento - Trous d'entrainement
Pinholes - Agujeros de arrastre

d Ø 30 e d Ø 32 = 2/11/63

α = -5°

40

F5-HW 

"Dry-cut" Lame circolari per ferro

"Dry-cut" Lames circulaires pour fer

"Dry-cut" TCT circular saw blades for iron

"Dry-cut" sierras circulares para hierro



Lame adatte al taglio del metallo, non necessitano di lubrificazione. Progettate per lavorare a secco, ad alti giri e per fornire un taglio pulito e netto di pieni ferrosi, tubolari e profilati.



Coupe à sec des matériaux ferreux sans nécessité de lubrification. Coupe rapide des matériaux ferreux grâce à son emploi sur machines équipées de moteurs à vitesse élevée. Coupe nette aussi bien sur fers pleins que sur tubulaires et profilés.



Strong and resistant blades for the dry cut of ferrous materials without lubrication. They enable a clean cut for full ferrous, tubular and profiles.



Cuchillas para el corte de metal, no necesitan de lubricación. diseñadas para trabajar en seco, con RpM elevado y para conseguir un corte nítido de hierros llenos, tubulares y perfiles.

	D mm	B/b mm	d	Z	€
LC1502602	150	2,2 - 1,6	20	26	42,00
LC1502603	150	2,2 - 1,6	30	26	42,00
LC1602803	160	2,2 - 1,6	20	28	45,00
LC1602802	160	2,2 - 1,6	30	28	45,00
LC1703001	170	2,2 - 1,6	20	30	49,00
LC1703002	170	2,2 - 1,6	30	30	49,00
LC1803201	180	2,2 - 1,6	20	32	52,00
LC1803202	180	2,2 - 1,6	30	32	52,00
LC1903202	190	2,2 - 1,6	30	32	52,00
LC2003401	200	2,2 - 1,6	30	34	56,00
LC2163601	216	2,2 - 1,6	30	36	57,00
LC2203801	220	2,2 - 1,6	30	38	59,00
LC2304001	230	2,2 - 1,6	30	40	61,00
LC2354001	235	2,2 - 1,6	30	40	61,00
LC2404201	240	2,2 - 1,6	30	42	62,00
LC2504805	250	2,4 - 1,8	30	48	67,00
LC2706001	270	2,4 - 1,8	30	60	76,00
LC3006005	300	2,4 - 1,8	30	60	78,00
LC3008001	300	2,4 - 1,8	30	80	90,00
LC3056003	305	2,4 - 1,8	25,4	60	80,00
LC3058001	305	2,4 - 1,8	25,4	80	92,00
LC3507001	350	2,5 - 2,0	30	70	103,00
LC3507002	350	2,5 - 2,0	25,4	70	103,00
LC3509001	350	2,5 - 2,0	30	90	123,00
LC3509002	350	2,5 - 2,0	25,4	90	123,00





$\alpha = 0^\circ$





Lame circolari HSS-M2 e HSS + Co 5% - M35
 Fraise scies HSS-M2 et HSS + Co 5% - m35
 Circular saws HSS-M2 and HSS + Co 5% - m35
 Cuchillas circulares HSS-M2 y HSS + Co 5% - M35



-  [art. F2-M2](#) Esecuzione vaporizzata
[art. F4-M35](#) Esecuzione vaporizzata Cobalto
-  [art. F2-M2](#) Execution vapeur
[art. F4-M35](#) Execution vapeur Cobalt
-  [art. F2-M2](#) Steam treated
[art. F4-M35](#) Steam treated Cobalt Steel
-  [art. F2-M2](#) Tratamiento al vapor
[art. F4-M35](#) Tratamiento al vapor - Cobalto

F2

DIAMETRO DIAMETRE DIAMETER DIÁMETRO	SPESSORE EPAISSEUR THICKNESS ESPEJOR	PASSO E NUMERO DEI DENTI - PAS ET NOMBRE DE DENTS PITCH AND NUMBER OF TEETH - PASO E NUMERO DE DIENTES								€
		T3	cod.	T4	cod.	T5	cod.	T6	cod.	
200	1,8	200	95005	160	95006	130	95007	100	95008	60,00
225	1,9	220	95105	180	95106	140	95107	120	95108	68,00
250	2,0	250	95205	200	95206	160	95207	128	95208	78,00
275	2,5	280	95305	220	95306	180	95307	140	95308	103,00
300	2,5	300	95405	220	95406	180	95407	160	95408	130,00
315	2,5	300	95505	240	95506	200	95507	160	95508	136,00
350	2,5	350	95605	280	95606	220	95607	180	95608	165,00

F4

DIAMETRO DIAMETRE DIAMETER DIÁMETRO	SPESSORE EPAISSEUR THICKNESS ESPEJOR	PASSO E NUMERO DEI DENTI - PAS ET NOMBRE DE DENTS PITCH AND NUMBER OF TEETH - PASO E NUMERO DE DIENTES								€
		T3	cod.	T4	cod.	T5	cod.	T6	cod.	
200	1,8	200	95005	160	95006	130	95007	100	95008	76,00
225	1,9	220	95113	180	95114	140	95115	120	95116	86,00
250	2,0	250	95213	200	95214	160	95215	128	95216	99,00
275	2,5	280	95313	220	95314	180	95315	140	95316	130,00
300	2,5	300	95413	220	95414	180	95415	160	95416	165,00
315	2,5	300	95513	240	95514	200	95515	160	95516	172,00
350	2,5	350	95613	280	95614	220	95615	180	95616	209,00

- Per dentature che esulano dalla tabella sopra citata, verrà applicata una maggiorazione sul prezzo del listino.
- Pour un nombre de dents qui n'est pas indiqué dans le tableau au-dessus, il y aura une augmentation de prix.

- Any other different teeth request, will be satisfied with an overprice.
- Para dentados no incluidos en el presente cuadro se aplicará un recargo sobre el precio de venta.

FORO - ALESAGE BORE - AGUJERO	FORI DI TRASCINAMENTO - TROUS D'ENTRAINEMENT PINHOLES - AGUJEROS DE ARRASTRE	DIAMETRO - DIAMETRE DIAMETER - DIÁMETRO
32	2 - 8 - 45 + 2 - 11 - 63	200 350
32	4 - 9 - 50 a richiesta / sur demande / on request / sobre pedido	200 250
40	2 - 8 - 55 - 4 - 12 - 64	250 350
40	2 - 15 - 80 a richiesta / sur demande / on request / sobre pedido	275 350
50	4 - 15 - 80	315 350
50	4 - 14 - 85 a richiesta / sur demande / on request / sobre pedido	315 350

- Fori centrali e fori di trascinamento speciali a richiesta.
- Alesages et trous d'entrainement speciaux sur demande.
- Special bores and pinholes on request.
- Pinchas centrales y agujeros de arrastre especial a solicitud

	DIAMETRO - DIAMETRE - DIAMETER - DIÁMETRO							
SFARFALLAMENTO VOILAGE RUN-OUT PARPADEO	200	225	250	275	300	315	350	
STANDARD	0,2	0,2	0,2	0,25	0,25	0,25	0,25	0,25

 **Angoli di taglio** Gli angoli con cui vengono fornite le lame circolari standard sono:

 **Cutting angles** The circular saw blades are manufactured with the following standard angles:

 **Angles de coupe** Les fraise scies de tronçonnage sont produites en standard avec angles de coupe:

 **Ángulos de corte** Las cuchillas están provistas con los siguientes ángulos:

HSS-M2 $\gamma = 18 \pm 2^\circ$
 $\alpha = 10 \pm 2^\circ$

HSS + Co 5% - M35 $\gamma = 12 \pm 2^\circ$
 $\alpha = 8 \pm 2^\circ$

MATERIALE - MATERIAUX MATERIAL - MATERIAL	RIVESTIMENTO - REVETEMENT COATING - REVESTIMIENTO
acciai dolci - aciers doux - mild steels - aceros dulces - 500~750 N/mm ²	vaporizzato - vapeur - steam - evaporado - TiCN - TiAlN
acciai duri - aciers durs - hard steel - aceros duros - 800~1000 N/mm ²	vaporizzato - vapeur - steam - evaporado - TiCN - TiAlN
acciai molto duri oltre - aciers tres durs plus de - very hard steels more than - aceros muy duros más allá de - 1000 N/mm ²	vaporizzato - vapeur - steam - evaporado - TiCN - TiAlN
acciai inossidabili - aciers inoxydables - stainless steels - aceros inoxidable	TiCN - TiAlN
ghisa - fonte - cast iron - hierro	TiAlN
alluminio - aluminium - aluminio	lucido - blanche - normal - lùcido - TiCN
avional	TiCN
bronzo - bronze - bronce	lucido - blanche - normal - lùcido
rame - cuivre - copper - cobre	lucido - blanche - normal - lùcido - TiCN
ottone - laiton - brass - latón	lucido - blanche - normal - lùcido - TiCN
nichel - nickel - níquel	TiCN - TiAlN
magnesio - magnesium - magnesium - magnesio	TiAlN
Inconel	TiCN - TiAlN
titanio - titane - titanium - titanio	TiAlN

FORMA DEI DENTI - FORMES DES DENTS - TEETH FORM - FORMA DE LOS DIENTES

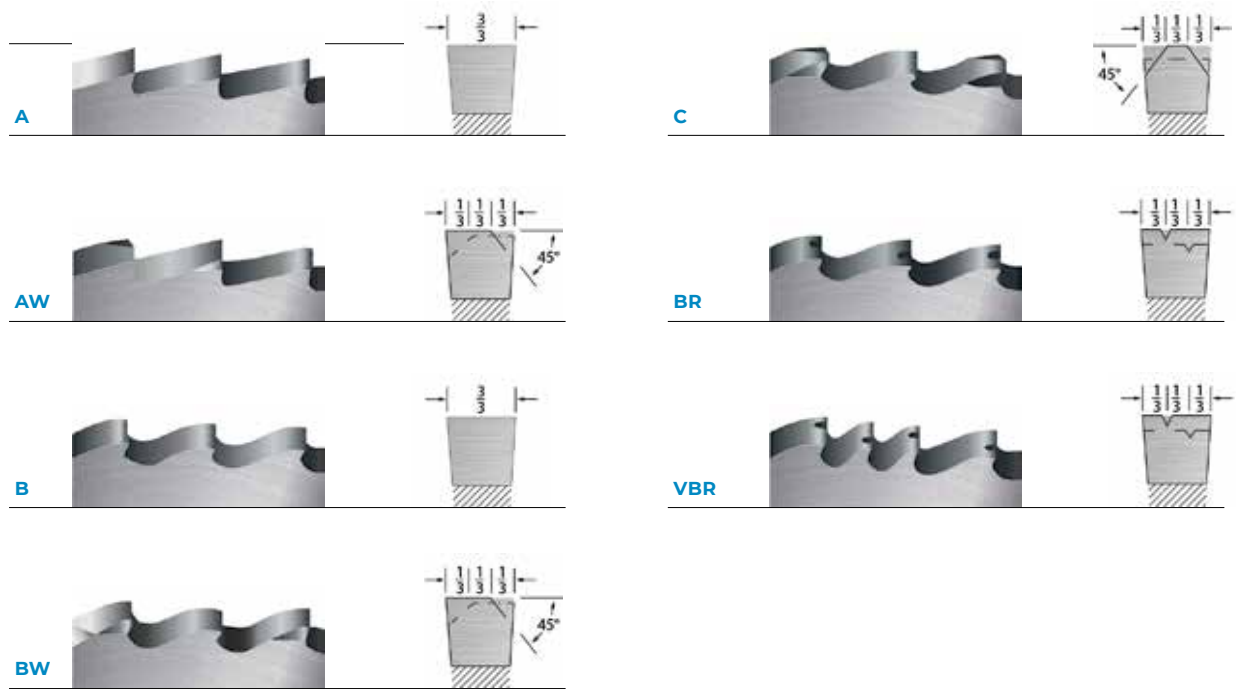

SCelta DEL PASSO E DELLA DENTATURA - CHOIX DU PAS ET DE LA DENTURE CHOICE FOR PITCH AND TEETH NUMBER - ELECCIÓN DEL PASO Y LA DENTADURA

PASSO PAS PITCH PASO	DESCRIZIONE DESCRIPTION DESCRIPTION DESCRIPCIÓN	SEZIONE DI TAGLIO SECTION DE COUPE CUT SECTION SECCIÓN DE CORTE
3 mm	Per tubi e profilati sottili con sezione da 1 a 2 mm Pour tubes et profilés parois minces de 1 à 2 mm d'épaisseur For cutting pipes with thickness from 1 to 2 mm Para tubos y perfiles finos con sección de 1 a 2 mm	
4 mm	Per tubi e profilati con sezione da 2 a 4 mm Pour barres fines, tubes et profilés de 2 à 4 mm d'épaisseur For cutting pipes with thickness from 2 to 4 mm Para tubos y perfiles con sección de 2 a 4 mm	
5 mm	Per profili con spessore medio, tubi e materiali con sezione da 4 a 15 mm Pour profilés d'épaisseur moyen, tubes et matériaux de 4 à 15 mm For cutting pipes and materials with thickness from 4 to 15 mm Por perfiles de espesor medio, tubos y materiales con sección de 4 a 15 mm	
6 mm	Per profili spessi, tubi e materiali con sezione da 15 a 30 mm Pour profilés épais, tubes et matériaux de 15 à 30 mm For cutting pipes and materials with thickness from 15 to 30 mm Para perfiles gruesos, tubos y materiales con sección de 15 a 30 mm	
8 mm	Per materiali spessi fino a 60 mm Pour matériaux épais, jusqu'à 60 mm d'épaisseur For cutting materials with thickness from 60 mm Para materiales hasta 60 mm de espesor	
10 mm	Per pieni con sezione da 60 mm e oltre Pour matériaux très épais, profilés pleins de 60 mm et plus For cutting solid with thickness from 60 mm and more Para materiales llenos de sección de 60 mm y más	



Trattamenti di superficie
 Traitements de surface
 Surface treatments
 Tratamientos superficiales



I diversi tipi di rivestimento superficiale vengono realizzati con la tecnologia PVD (Physical Vapor Deposition) con formazione di nitruri, carburi e carbonitruri metallici.

Spessore del rivestimento 3 μm .



Les différents types de traitement de surface sont réalisés par la technologie PVD (Physical Vapor Deposition) avec la formation de nitrures, et carbonitrures métalliques.

Revetement avec épaisseur de 3 μm .



The various special surface treatments are realized with PVD (Physical Vapor Deposition) with formation of nitrides, carbides and metal carbintrides.

Coating with a titanium base 3 μm thick.



Los diferentes tipos de revestimiento superficial están realizados con tecnología PVD (Physical Vapor Deposition), con formación de nitruros, carburos y carbonitruros metálicos.

Espesor del revestimiento: 3 μm .

TiN HV 2200 / 2400

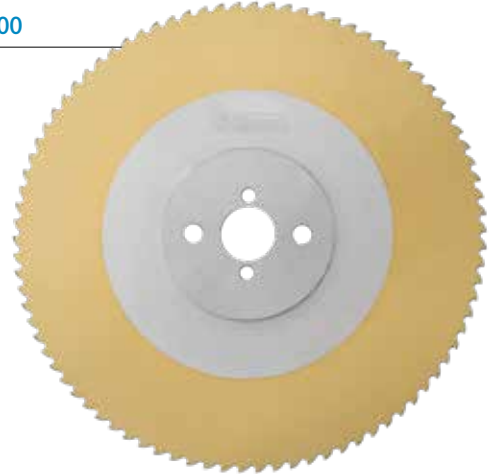

TiCN HV 3000 / 3300

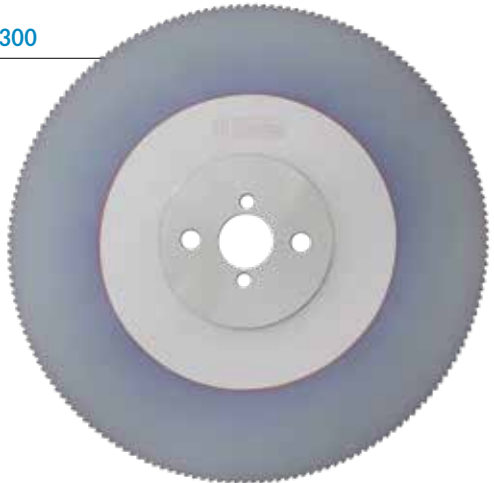

TiAlN HV 3300 / 3500



ART. K - M42 - SEGHE A NASTRO BIMETALLICHE

LAME DE SCIES RUBAN BIMETALLIQUES - BIMETALLIC BAND SAWS - SIERRAS DE CINTA BIMETÁLICAS

ART.	L (mm)	h (mm)	€
K1306	1140	13	17,50
	1325	13	19,50
	1335	13	19,50
	1440	13	21,50
	1735	13	24,00
K2009	1900	20	29,50
	2080	20	31,50
	2140	20	32,00
	2465	20	35,50
K2709	2400	27	36,00
	2450	27	36,50
	2470	27	36,50
	2500	27	37,00
	2520	27	37,00
	2550	27	37,50
	2570	27	37,50
	2600	27	38,00
	2630	27	38,00
	2650	27	38,50
	2670	27	38,50
	2700	27	39,00
	2725	27	39,50
	2750	27	39,50
	2760	27	39,50
	2770	27	40,00
	2800	27	40,00
	2810	27	40,00
	2825	27	40,50
	2845	27	40,50
	2850	27	40,50
	2870	27	41,00
	2900	27	41,00
	2925	27	41,50
	2950	27	42,00
	2970	27	42,00

ART.	L (mm)	h (mm)	€
K2709	3000	27	42,50
	3010	27	42,50
	3020	27	42,50
	3050	27	43,00
	3070	27	43,00
	3100	27	43,50
	3120	27	43,50
	3150	27	44,00
	3180	27	44,50
	3200	27	44,50
	3220	27	45,00
	3250	27	45,00
	3270	27	45,50
	3300	27	45,50
	3320	27	46,00
	3350	27	46,50
	3370	27	46,50
	3400	27	47,00
	3420	27	47,00
	3450	27	47,50
	3470	27	47,50
	3500	27	48,00
	3520	27	48,00
	3550	27	48,50
	3570	27	49,00
	3600	27	49,00
	3620	27	49,50
	3650	27	49,50
	3660	27	50,00
	3700	27	50,00
	3720	27	50,50
	3750	27	50,50
	3770	27	51,00
	3800	27	51,50
	3820	27	51,50
	3850	27	52,00
	3870	27	52,00
	3900	27	52,50
	3920	27	52,50
	3950	27	53,00
	3970	27	53,00
	4000	27	53,50



SEGHE A NASTRO BIMETALLICHE IN ROTOLI - LAME DE SCIES RUBAN BIMETALLIQUES EN ROULEAU BIMETALLIC COIL BAND SAWS - SIERRAS DE CINTA BIMETÁLICAS EN ROLLOS

ROTOLO - ROULEAU - COIL - ROLLO	DIMENSIONI - DIMENSIONS - SIZES - MEDIDAS (mm)	€
~ 75 / 80 m	20 X 0,9	11,00
~ 75 / 80 m	27 X 0,9	11,50
~ 75 / 80 m	34 X 1,1	17,00

TABELLA PER LA SCELTA DELLA DENTATURA - TABLE POUR LE CHOIX DE LA DENTURE TABLE FOR TOOTH CHOICE - TABLERO POR LA ELECCIÓN DEL DENTADO

- Tubi, profili, travi
- Tubes, profiles, faisceaux
- Pipes, profiles, beams
- Tubos, perfiles, vigas

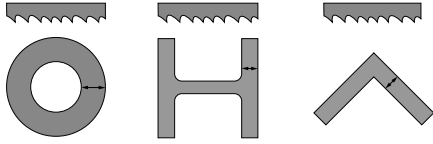

mm	2	345	67	89	10	15	20	25	30	40	50
Z x 25 mm	$\frac{20}{14}$	$\frac{8}{12}$	$\frac{6}{10}$	$\frac{5}{8}$	$\frac{4}{6}$			$\frac{3}{4}$		$\frac{2}{3}$	

- Tondo pieno
- Barres pleines
- Round bars
- Redondo lleno

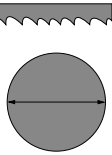

mm	5	10	15	20	25	50	75	100	200	300	400	500	600	700	800	900	1000	1100	1200	
Z x 25 mm	$\frac{10}{14}$	$\frac{8}{12}$	$\frac{6}{10}$	$\frac{5}{8}$		$\frac{4}{6}$		$\frac{3}{4}$	$\frac{2}{3}$	$\frac{1,4}{1,0}$		$\frac{1,0}{1,3}$						$\frac{0,7}{1,0}$		

- Quadro rettangolo pieno
- Carre rectangle plein
- Square rectangle bars
- Cuadro rectángulo lleno

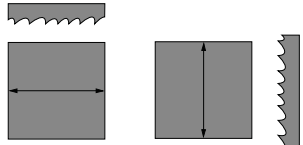

mm	5	10	15	20	25	50	75	100	200	300	400	500	600	700	800	900	1000	1200		
Z x 25 mm	$\frac{10}{14}$	$\frac{8}{12}$	$\frac{6}{10}$	$\frac{5}{8}$		$\frac{4}{6}$		$\frac{3}{4}$	$\frac{2}{3}$	$\frac{1,4}{2,0}$		$\frac{1,0}{1,3}$						$\frac{0,7}{1,0}$		

- Forma del dente
- Forme de dents
- Tooth form
- Forma del diente

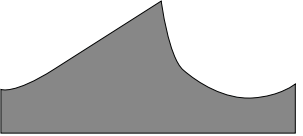
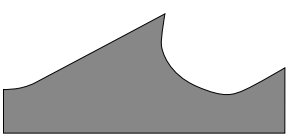
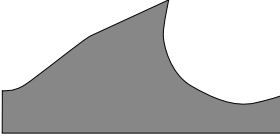
<p>N = 0°</p>  <p>Per profili Pour profiles For profiles Para perfiles</p>	<p>H = 6° - 10°</p>  <p>Per medio grosse sezioni Pour parois epaisses et moyennes For big and medium sections Para secciones medias y grandes</p>	<p>S = 10° - 16°</p>  <p>Per grosse sezioni Pour parois epaisses For big sections Para secciones grandes</p>
---	---	---

— Condizioni generali di vendita

Le presenti "Condizioni Generali di Vendita" si intendono accettate, con il conferimento di ogni ordinazione da parte del Committente. Qualsiasi variazione sarà valida solo se accettata dalla FIRST ITALIA SRL per iscritto.

- **ORDINI** - Si intendono accettati, solo con l'emissione della nostra conferma e non potranno essere revocati, né integralmente, né parzialmente dal Committente. Gli ordini per articoli non standard di magazzino, previa accettazione da parte del nostro ufficio tecnico, possono essere evasi con il quantitativo che supera il collaudo e che potrà pertanto essere superiore o inferiore alla quantità o al valore ordinato, compreso in una tolleranza di +5% e -10% con un minimo di 1 pezzo. Per le forniture di importo inferiore a 250,00 € netti, sarà addebitato l'importo fisso di 25,00 € netti, a titolo di concorso, per le maggiori spese di gestione.

- **CONSEGNA** - I termini di consegna sono approssimativi e mai impegnativi; subordinati ad impedimenti di produzione, per cause di forza maggiore. Ci riserviamo la facoltà di effettuare anche consegne parziali.

- **PREZZI** - Il listino prezzi della FIRST ITALIA SRL è soggetto a modifica in qualsiasi momento e senza preavviso. I prezzi si intendono IVA esclusa e non sono impegnativi. Non saranno modificati prima dell'evasione dell'ordine, se non interverranno sensibili variazioni nei costi delle materie prime, della manodopera o dell'energia.

- **SPEDIZIONI** - La merce viene fornita franco nostro stabilimento e viaggia sempre ed esclusivamente a rischio del destinatario, indipendentemente dalle condizioni di addebito del trasporto. Non verranno bonificati danni o ammanchi durante la resa.

- **IMBALLO** - Viene sempre addebitato al costo.

- **UTILIZZO** - Il materiale fornito dalla FIRST ITALIA SRL dovrà essere sempre utilizzato con l'osservanza di tutte le norme legislative di prevenzione infortuni. Non potrà essere altresì manipolato e/o modificato senza la preventiva autorizzazione scritta da parte della FIRST ITALIA SRL.

- **RECLAMI-RESI** - Eventuali contestazioni, relative alla quantità e alla qualità dei prodotti forniti, dovranno pervenire alla FIRST ITALIA SRL in forma scritta, entro dieci giorni dalla data di ricevimento. Non si accetteranno, per qualsiasi motivo, restituzioni non preventivamente autorizzate dalla FIRST ITALIA SRL. Eventuali resi sono a carico del committente.

- **GARANZIA** - I prodotti sono forniti con 24 (ventiquattro) mesi di garanzia per vizi occulti. Durante tale periodo, ad insindacabile giudizio FIRST ITALIA SRL e per i comprovati casi di opportunità, si provvederà alla sostituzione dei particolari difettosi, restando escluso ogni altro onere, a qualsiasi titolo.

- **PAGAMENTI** - Dovranno pervenire, nei termini e nelle forme stabilite in conferma e in fattura, alla sede della FIRST ITALIA SRL. Non sono ammessi né arrotondamenti, né trattenute a qualsiasi titolo.

La non ottemperanza, da parte del Committente, darà diritto alla FIRST ITALIA SRL di sospendere eventuali nuove forniture, consentendole contemporaneamente di addebitare gli interessi passivi maturati ed ogni altro onere accessori. Il passaggio di proprietà dei prodotti forniti dalla FIRST ITALIA SRL al Committente, avverrà al completo saldo della fattura di fornitura.

- **LEGGE E FORO COMPETENTE** - Ogni rapporto tra la FIRST ITALIA SRL ed il Committente, si intende regolato dalla Legge Italiana. Per eventuali controversie, viene riconosciuta l'esclusiva competenza del Foro di Torino.

— Conditions générales de vente

Les présentes "Conditions Générales de Vente" sont considérées comme acceptées, lorsqu'une commande est passée par le Client. Toute variation ne sera valable que si elle est acceptée par FIRST ITALIA SRL par écrit.

- **COMMANDES** - Elles sont considérées comme acceptées, uniquement par l'émission de notre confirmation sans aucune possibilité d'être révoquées, ni entièrement ni partiellement par le Client. Les commandes d'articles non standards en stock, sous réserve d'acceptation par notre bureau technique, peuvent être traitées avec la quantité qui passe le test et par conséquent, être supérieures ou inférieures à la quantité ou à la valeur de la commande, dans une tolérance comprise entre +5 % et -10 % avec un minimum de 1 pièce. Pour les fournitures d'un montant net inférieur à 250,00 €, le montant fixe de 25,00 € net sera facturé, à titre de participation aux coûts d'exploitation plus élevés.

- **LIVRAISON** - Les conditions de livraison sont approximatives et en aucun cas contraignantes; elles peuvent être conditionnées par les empêchements de production, en cas de force majeure. Nous nous réservons le droit de faire également des livraisons partielles.

- **PRIX** - La liste de prix de FIRST ITALIA SRL peut être modifiée à tout moment et sans préavis. Les prix n'incluent pas la TVA et ne sont pas contraignants. Ils ne seront pas modifiés avant tout traitement de la commande, sauf si des variations significatives surviennent dans les coûts des matières premières, de la main d'œuvre ou de l'énergie.

- **EXPÉDITION** - Les marchandises sont livrées départ usine et voyagent toujours et exclusivement aux risques et périls du destinataire, quelles que soient les conditions de chargement du transport. Aucun dommage ou pénurie ne sera couvert pendant la retour.

- **EMBALLAGE** - Il est toujours facturé au prix coûtant.

- **UTILISATION** - Le matériel fourni par FIRST ITALIA SRL doit impérativement être utilisé en se conformant à toutes les réglementations en matière de prévention des accidents. Il ne peut être altéré et / ou modifié sans l'autorisation écrite préalable de FIRST ITALIA SRL.

- **RECLAMATIONS-RETOURS** - Tous les contestations en matière de quantité et qualité des produits fournis doivent être envoyés à FIRST ITALIA SRL par écrit, dans les dix jours à compter de la date de réception. Tout retour, sans autorisation préalable par FIRST ITALIA SRL ne sera accepté sous aucun prétexte. Tout retour est à la charge du client.

- **GARANTIE** - Les produits sont fournis avec 24 (vingt-quatre) mois de garantie pour les vices cachés. Pendant cette période, à la seule discrétion de FIRST ITALIA SRL et avec des informations avérées prouvant de graves situations de non-conformité, nous remplacerons les pièces défectueuses, à l'exclusion de toute autre charge, pour quelque raison que ce soit.

- **PAIEMENTS** - Ils doivent être reçus, dans les termes et dans les formes établies dans la confirmation et la facture, au siège de FIRST ITALIA SRL. Aucun arrondi, aucune déduction n'est autorisée sous aucun prétexte. Le non-respect de la part du Client autorisera FIRST ITALIA SRL à suspendre toute nouvelle fourniture, en lui permettant simultanément de débite les intérêts courus et tous les autres frais accessoires. Le transfert de la propriété des produits fournis par FIRST ITALIA SRL au Client se fera lors du solde total de la facture de fourniture.

- **LOI ET TRIBUNAL COMPETENT** - Toute relation entre FIRST ITALIA SRL et le Client est régie par la loi italienne. Tout litige sera de la compétence exclusive du Tribunal de Turin.

— General sales condition

These "Conditions of Sale" are deemed accepted at the moment when an order is placed by the Buyer. Any change will be deemed valid only if accepted in writing by FIRST ITALIA SRL.

- **ORDERS** - Orders will be deemed accepted only after an order confirmation is issued and cannot be cancelled in full or in part by the Buyer. Orders for non-standard items, after being accepted by our Technical Office, can be dispatched in the quantity of successfully tested items and can therefore be higher or lower than the quantity of value ordered, within a tolerance between +5% and -10% and a minimum of 1 item. For order values lower than 250,00 € net, a fixed charge of 25,00 € net will be applied as a contribution to the higher operating costs incurred.

- **DELIVERY** - Delivery terms are approximate and never binding and are subject to disruptions in production caused by force majeure. We reserve the right to ship part orders.

- **PRICES** - FIRST ITALIA SRL's price list is subject to changes at any time and without any notice. Prices do not include VAT and are not binding. The prices will not be changed before dispatching the order, unless significant increases in costs of raw materials, labour and energy occur.

- **SHIPMENTS** - Goods are shipped ex-works and the recipient is always and solely responsible for their transport, regardless of the shipping charging conditions. No damages or missing items occurred during transport will be refunded.

- **PACKAGING** - Packaging cost is always charged to the Buyer.

- **USE** - The material supplied by FIRST ITALIA SRL must always be used in compliance with health, safety and accident prevention legislation. In addition, it cannot be altered and/or modified without the prior written approval granted by FIRST ITALIA SRL.

- **COMPLAINTS-RETURNS** - Any complaints related to the quantity and quality of products supplied must be notified to FIRST ITALIA SRL in writing within ten days from the date of receipt. Returns not previously approved by FIRST ITALIA SRL will not be accepted for any reason whatsoever. The cost of returning goods will be borne by the Buyer.

- **WARRANTY** - Products are supplied with a 24 (twenty-four) month warranty against latent defects. During the warranty period FIRST ITALIA SRL will, at its sole discretion, and for substantiated suitable cases, replace the defective parts without being liable for any other charges of whatever nature.

- **PAYMENTS** - Payments must be received, within the terms and methods specified in the order confirmation and in the invoice, at the offices of FIRST ITALIA SRL. The amount due cannot be rounded up or partly withheld for whatever reason.

The Buyer's non compliance will give FIRST ITALIA SRL the right to stop any future supplies, as well as to charge the Buyer passive interests accrued and any ancillary costs. Ownership of the products supplied by FIRST ITALIA SRL will be passed on to the Buyer when the invoice is paid in fully.

- **JURISDICTION AND GOVERNING LAW** - All sales agreements between FIRST ITALIA SRL and the Buyer shall be governed by Italian law.

Disputes that may arise between the Parties shall be settled by the Turin Court of Law.

— Condiciones generales de venta

Estas "Condiciones Generales de Venta" se consideran aceptadas con la concesión de cada pedido por parte del Comite. Cualquier variación solamente será válida si es aceptada por escrito por la empresa FIRST ITALIA SRL.

- **PEDIDOS** - Solamente se consideran aceptados si se emite una confirmación por nuestra parte, y no podrán ser revocados por el Comite ni parcial ni totalmente. Los pedidos para artículos no estándar de almacén, previa aceptación por parte de nuestro departamento técnico, pueden tramitarse con la cantidad que supera la prueba y que, por lo tanto, podrá ser superior o inferior a la cantidad o al valor pedido, incluido en el rango de tolerancia de entre +5 y -10% con un mínimo de 1 pieza. Para las entregas con un importe superior a 250,00 € netos, se cobrará el importe fije de 25,00 € netos en concepto de asistencia, por gastos de gestión mayores.

- **ENTREGA** - Los plazos de entrega son aproximados y nunca vinculantes; sujetos a impedimentos relacionados con la producción, por causa de fuerza mayor. Nos reservamos la facultad de realizar entregas parciales.

- **PRECIOS** - La lista de precios de la empresa FIRST ITALIA SRL está sujeta a modificaciones en cualquier momento y sin previo aviso. Los precios se consideran sin IVA y no son vinculantes. No se modificarán antes de la tramitación del pedido, a no ser que se produzcan variaciones importantes en los costes de las materias primas, de la mano de obra o de la energía.

- **ENVÍOS** - La mercancía es entregada franco fábrica y viaje siempre y exclusivamente por cuenta y riesgo del destinatario, con independencia de las condiciones de pago del transporte. No se bonificarán daños ni defectos durante la entrega.

- **EMBALAJE** - Siempre se añade al precio del coste.

- **USO** - El material suministrado por la empresa FIRST ITALIA SRL deberá ser utilizado siempre cumpliendo con todas las normativas de prevención de accidentes. Además, no podrá ser manipulado ni modificado sin la autorización previa por escrito de la empresa FIRST ITALIA SRL.

- **RECLAMACIONES-DEVOLUCIONES** - Las eventuales reclamaciones relativas a la cantidad y a la calidad de los productos suministrados deberán enviarse por escrito a la empresa FIRST ITALIA SRL, en un plazo de diez días desde la fecha de recepción. No se aceptan, en ningún caso, devoluciones que no hayan sido autorizadas previamente por la empresa FIRST ITALIA SRL. Las eventuales devoluciones corren por cuenta del comite.

- **GARANTÍA** - Los productos se entregan con 24 (veinticuatro) meses de garantía por defectos ocultos. Durante dicho periodo, al juicio indiscutible de la empresa FIRST ITALIA SRL y para los casos comprobados y relevantes, se procederá a la sustitución de las piezas defectuosas, excluyéndose cualquier otro gasto de cualquier naturaleza.

- **PAGOS** - Deberán llegar, en los plazos y en las formas establecidas y confirmadas en la factura, a la sede de la empresa FIRST ITALIA SRL. No se admiten ni redondeos ni retenciones de ningún tipo.

El incumplimiento por parte del Comite dará derecho a la empresa FIRST ITALIA SRL a suspender eventuales entregas futuras, permitiéndole, al mismo tiempo, cobrar los intereses pasivos devengados y cualquier otro gasto accesorio. El traspaso de propiedad de los productos suministrados por la empresa FIRST ITALIA SRL al Comite se producirá una vez abonado todo el saldo de la factura de suministro.

- **LEY Y JURISDICCIÓN COMPETENTE** - Cualquier relación entre la empresa FIRST ITALIA SRL y el Comite se considera disciplinada por la Ley Italiana. En el caso de eventuales litigios solamente será competente el Tribunal de Turin.

FIRST ITALIA Srl

strada della Berlia, 80 - 10093 Collegno (TO) - ITALY
tel. +39.011.712216- fax +39.011.712105
e-mail: commerciale@firstitaly.it

www.firstitaly.it