

Soluzioni di fissaggio per impianti industriali e per pannelli fotovoltaici



Catalogo
prodotti



TEKNOMEGA®

iPad

3:02 PM

51%



Ω Clip



Ω Clip



Ω Clip



Ω Clip



Ω Strut



Ω Strut



Ω Strut



Ω Strut



Ω Clamp



Ω Clamp



Ω Clamp



Ω Clamp



Ω Zip



Ω Zip



Ω Zip



Ω Zip



Quadristica



Fissaggio



Sismico



Fotovoltaico

GIOVANE, SOLIDA E COMPETENTE

*"Noi siamo ciò che facciamo ripetutamente.
Quindi l'eccellenza non sta in un singolo atto, ma nel comportamento"*
(Aristotele)

A **quindici anni** dalla sua fondazione Teknomega è una solida realtà di **riferimento** nel mondo elettrico industriale. **L'identità** peculiare che la contraddistingue è fatta di una rete di **rapporti** fra persone, unitamente ad un **rigore** organizzativo che ha radici **nell'esperienza** dei dirigenti che la guidano.

Le **accresciute conoscenze**, allineate all'evoluzione delle normative, la cultura del **servizio**, concretizzata nel tessuto operativo, e la **passione** che le donne e gli uomini di Teknomega esprimono quotidianamente in ciò che fanno, rendono Teknomega un **partner** affidabile per i propri distributori e clienti, sparsi in 65 Paesi del mondo; distributori e clienti che hanno premiato Teknomega con elevati tassi di **crescita**, anche in tempo di crisi. **Grazie, signori clienti!**

L'ambizione ad emergere, la **creatività** impiegata sia nelle modalità operative che nella generazione di nuovi prodotti, il piacere di **lavorare e dare lavoro** ad una **squadra** sempre più folta, fanno di Teknomega una piccola **stella brillante** nella variegata galassia del materiale elettrico; una stella di cui andiamo orgogliosi.

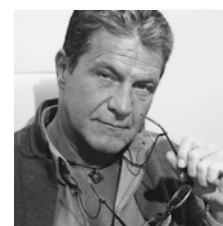

Maurizio Mercandelli
Amministratore
Delegato



Sede centrale e Centro logistico di Buccinasco, Milano

GLI ELEMENTI CARATTERIZZANTI

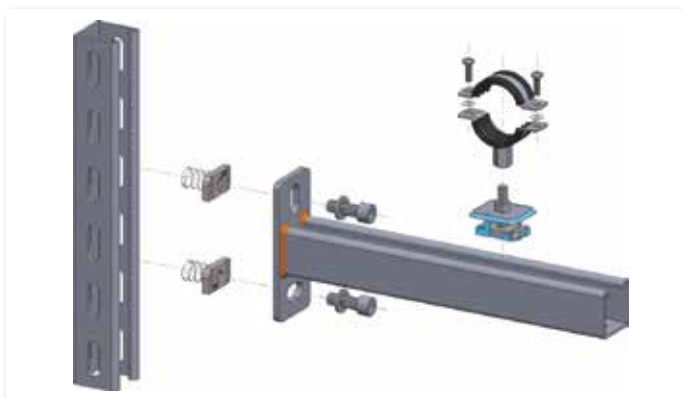

Qualità - R&D

L'impegno di Teknomega in fatto di qualità non è uno slogan: è uno stile, una scommessa sulla competitività stessa dell'azienda, un valore irrinunciabile nel Business to Business. L'apparato di Ricerca e Sviluppo è attivo sulla crescita dell'offerta, al fine di soddisfare un numero crescente di impieghi e mercati, che in Teknomega è obiettivo fondamentale.



Reattività

Il nostro Customer Service ha personalità. Persone che amano il proprio lavoro al servizio dei loro clienti, lontano dalla logica del call center; persone che si fanno carico delle necessità degli interlocutori con sagacia e creatività.



Prontezza

Lo step successivo al Customer Service è un Centro Logistico organizzato, efficientemente informatizzato, in grado di reagire flessibilmente alle sollecitazioni, contando su imponenti stoccaggi di tutto ciò che il catalogo presenta.



Capillarità

Il partenariato con selezionati distributori di materiale elettrico, nonché di importatori settorialmente specializzati nel mondo, rende la disponibilità non solo del prodotto, ma anche di interlocutori e informazioni, decentrata e capillare.



Internazionalità

L'attrattività di Teknomega, della sua gamma e del suo modo di operare, si è rapidamente spinta oltre i confini nazionali ed europei, fino a rendere disponibile il prodotto in oltre 65 Paesi nel mondo.



Aggiornamento

Essere sempre "up to date" su normative tecniche e tecnologie, prestare attenzione all'evoluzione della domanda, farci propositori di innovazione, è parte del nostro bagaglio imprenditoriale.



Presenza

In Italia come all'estero, nelle fiere e nelle manifestazioni, o attraverso il nostro efficace sito www.teknomega.it, con la forza vendita e con le nostre newsletters, manteniamo un elevato livello di presenza e comunicazione con la clientela.



Riconoscimenti

L'organizzazione Teknomega è stata insignita della certificazione ISO9001:2015; ben più di un pezzo di carta, un riconoscimento della validità dell'impianto operativo e di controllo.

Tecniche e soluzioni di fissaggio per impianti industriali

Nei più disparati settori dell'impiantistica, i sistemi di fissaggio rappresentano l'anello di congiunzione tra struttura portante ed i componenti degli impianti che la percorrono. Teknomega si presenta al mercato con le credenziali di chi ha acquisito una competenza specialistica nel settore dei Sistemi di Fissaggio, unendo ad uno specifico affiancamento in fase di progettazione, una rete di Distributori selezionati che consente di rispondere in modo efficace a tutte le richieste provenienti dai cantieri. Un'offerta la cui forza è rappresentata da una vasta gamma di prodotti innovativi, certificati e conformi ai più elevati standard qualitativi. Teknomega studia le strategie atte a soddisfare le più svariate esigenze di cantiere, garantendo agli utilizzatori finali un considerevole vantaggio in termini di tempo e denaro risparmiato.

SOMMARIO

Ω CLIP	Fissaggi in acciaio armonico per travi metalliche	11
Ω STRUT	Profili in acciaio	28
	Tabelle carichi profili	38
Ω STRUT	Mensole in acciaio	44
	Tabelle carichi mensole	47
Ω STRUT	Staffe in acciaio - Zincate a caldo	48
Ω STRUT	Accessori	55
	Dadi per profili	56
	Fast Kit e Viti testa a martello	58
	Viti e dadi in acciaio inox	59
	Viti e dadi in acciaio zincato	60
	Barre Filettate e manicotti	61
	Viti autofilettanti per calcestruzzo	62
	Catenella	62
Ω STRUT	U-Bolt Cavalletto fissa tubo	63
	Collari per profilo	63
	Collari isolati in EPDM	64
Ω CLAMP	Morsetti in ghisa per travi metalliche	64
	Morsetti in acciaio per travi metalliche	65
	Collari ad incastro	65
	Fissaggi per travi in cemento	66
Ω ZIP	Sistemi di sospensione in cavo d'acciaio	68
	Cavi e morsetti	69
	Terminale a cappio	70
	Terminale ad ancorina	71
	Terminale ad anello	72
	Terminale a tassello	73
	Soluzioni per tesate	74
	Sospensioni per tesate	75
	Sospensioni per rack multi livello	76
	Terminale a moschettone e supporti ad "Y"	77
	Cavi per controventature sismo-resistenti	78
	Accessori	78
Ω SOLAR	Fissaggio per pannelli fotovoltaici	80
	Elenco Codici Alfanumerico	129

LEGENDA

DIMENSIONI

- A** = Spessore min. max. della IPE/profilo metallico
- B** = Profondità min., altezza o largh. max. del profilo metallico
- M** = Foro filettato
- D** = Foro passante Ø... o Diametro utilizzabile
- L** = Lunghezza in metri

CARICHI

- CL kg** = Carico statico di lavoro espresso in kg fattore di sicurezza CLIP 3:1 / ZIP 5:1
- CM kg** = Carico massimo ammissibile espresso in kg fattore di sicurezza 1:1

FINITURA (F)

- A** = Rivestimento anti corrosione in strato di zinco/alluminio senza cromo resistente alla corrosione secondo norme DIN 50021 e ISO 9227
- D** = Dacromet®
- E** = Zincatura elettrolitica secondo UNI 4721
- G** = Ghisa malleabile-zincatura elettrolitica
- L** = Laccatura bianca RAL 9010
- M** = Magnelis®
- S** = Zincatura Sendzimir
- SS** = Acciaio Inossidabile AISI304
- T** = Zincatura elettrolitica passivata
- Z** = Zincatura a caldo secondo DIN 50976-CEI 7.6

INSTALLARE CON:



Mano



Cacciavite



Martello



Trapano



Chiave

APPLICARE SU:



Trave cemento



Pendino metallico



Putrella metallica



Muro cemento



Profilo metallico



Lamiera grecata



Profilo controsoffitto



Tetto a falda



Barra filettata



Tetto piano

Ω CLIP - SERIE EASY

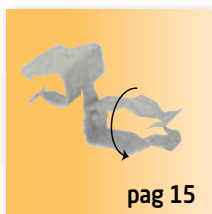
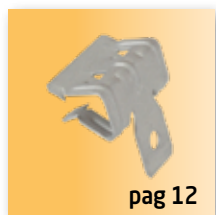

Ω CLIP - SERIE FAST



Ω CLIP - SERIE MEGA



Ω CLIP - SERIE HOOK



Ω CLIP - SERIE TOP



Ω CLIP - SERIE CLAMP



Ω CLIP - SERIE PINCH



Ω CLIP - ACCESSORI



Ω STRUT



Ω STRUT - ACCESSORI



Ω CLAMP



Ω ZIP

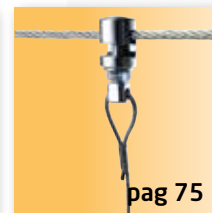
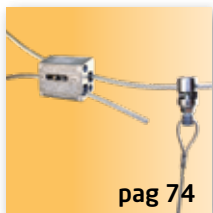
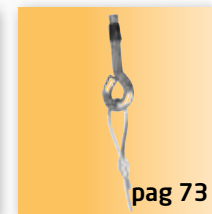
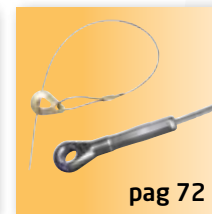
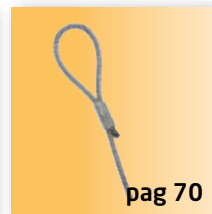

Ω ZIP - ACCESSORI

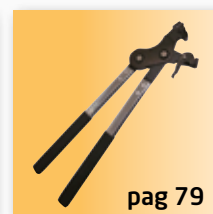
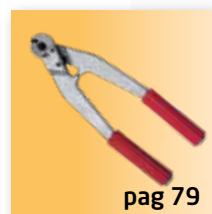

Ω ALU

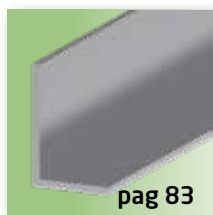

Ω STRUT



Ω SOLAR



Ω FIX



Ω FIX

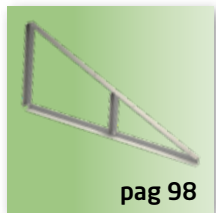
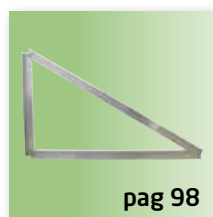
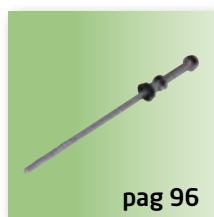
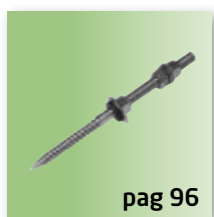

Ω STRUT

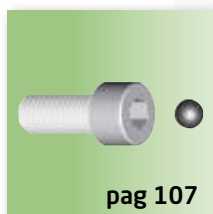

Ω BLOCK





Ω CLIP - Clip in acciaio armonico

Caratteristiche del prodotto

La gamma di fissaggi rapidi Ω CLIP, rappresenta la soluzione ideale per connettere strutture metalliche, portanti e non, con la maggior parte degli elementi costituenti gli impianti sia elettrici che meccanici.

RAPIDITÀ: il montaggio, semplice e veloce, rappresenta un notevole risparmio in termini di tempo offrendo all'installatore la possibilità di risparmiare fatica ma soprattutto denaro.

GAMMA: una vasta gamma di referenze e di combinazioni che ben si adattano a tutte le problematiche tecniche.

SICUREZZA e COMODITÀ: non è necessario realizzare alcun foro o, tantomeno, saldature sulla struttura metallica; non sono richiesti specifici utensili né specifiche abilità per la messa in opera di queste soluzioni.

MODO D'IMPIEGO: l'installazione di tutti gli elementi Ω CLIP, è facile e rapida, un semplice colpo di martello o un "giro" di cacciavite sono le uniche operazioni richieste per creare un fissaggio solido ed affidabile.

CARICHI: tutti gli elementi della gamma di fissaggio Ω CLIP, vengono testati e controllati a campione prima dell'imballo.

I carichi indicati nelle tabelle, considerano un coefficiente di sicurezza 3 : 1.

MATERIALE IMPIEGATO: acciaio armonico secondo norme DIN 17222 (UNI-EN 10132-4); acciaio che, dopo il trattamento al quale viene sottoposto, acquisisce una durezza HRC 43 ± 50.

PROTEZIONE ANTICORROSIONE:

Finitura brevettata tipo A: per applicazioni all'interno, esterno, ambienti umidi e leggermente corrosivi.

- Rivestimento non elettrolitico di zinco e alluminio, depositati e fissati sull'acciaio, grazie ad una reazione chimica.
- Rivestimento non idrogenato (senza elettrolitici o decapaggi acidi).
- Conducibilità elettrica. Alta resistenza alla temperatura. I valori di carico sono validi per temperature tra +5 e +35° C.
- Assenza di Cromo VI o Cromo III. Alta protezione contro la corrosione catodica.
- Aspetto visivo: Grigio - Argento.

** Su richiesta disponibili anche con protezione Zinco fosfatato nero.

Tutti i prodotti sono testati in nebbia salina fino a 480 ore (secondo DIN 50021).

SUGGERIMENTI: i valori di portata indicati a catalogo, sono da interpretare come indicazione di un carico statico, applicato verticalmente alla struttura "max inclinazione ± 15°". Quando due o più elementi di fissaggio sono combinati tra loro, il valore del carico di portata deve ritenersi quello relativo all'elemento con il valore inferiore. Se la struttura alla quale è applicato l'elemento ha un valore di portata inferiore al carico di portata dell'elemento stesso, questa determinerà il valore di carico massimo applicabile.

Ω CLIP - Clip in acciaio armonico SERIE EASY

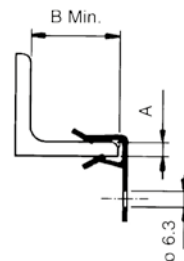
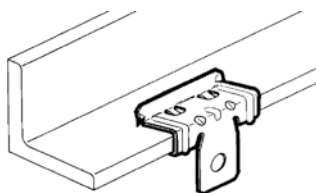

BASE

Codice	Riferimento		F	A (mm)	B (mm)	CL (kg)
CLP1000	CLP-H1	100	A	1,5÷4	18	70
CLP1005	CLP-H2	100	A	4÷10	25	90
CLP1010	CLP-H3	100	A	10÷15	25	90
CLP1015	CLP-H4	100	A	15÷20	25	90

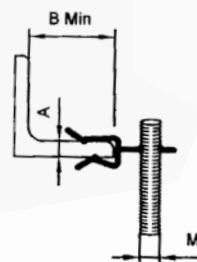
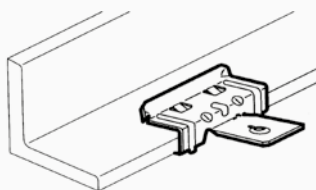

ORIZZONTALE

Codice	Riferimento		F	A (mm)	B (mm)	M	CL (kg)
CLP1035	CLP-H2-I	100	A	4÷10	25	M6	20
CLP1040	CLP-H3-I	100	A	10÷15	25	M6	20

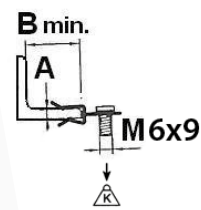
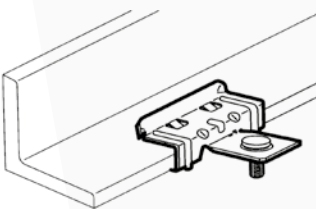

ORIZZONTALE CON VITE

Codice	Riferimento		F	A (mm)	B (mm)	CL (kg)
CLP1045	CLP-H2-IX	100	A	4÷10	25	20
CLP1050	CLP-H3-IX	100	A	10÷15	25	20

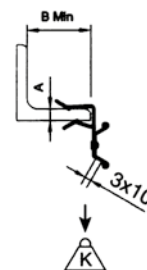
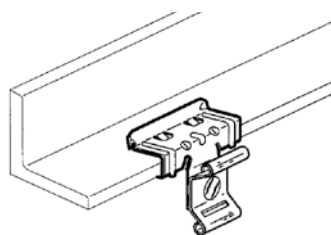

CON PORTA - FASCETTA

Codice	Riferimento		F	A (mm)	B (mm)	CL (kg)
CLP1055	CLP-H1-CT	100	A	1,5÷4	18	15
CLP1060	CLP-H2-CT	100	A	4÷10	25	15
CLP1065	CLP-H3-CT	100	A	10÷15	25	15
CLP1070	CLP-H4-CT	100	A	15÷20	25	15

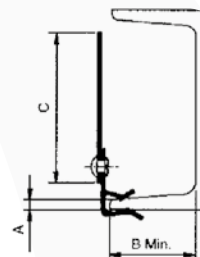
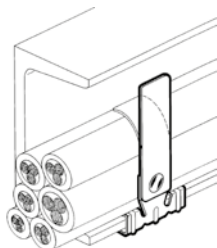

CON LAMIERINO METALLICO

Codice	Riferimento		F	A (mm)	B (mm)	C (mm)
CLP1770	CLP-H1-LM	100	A	1,5÷4	18	75
CLP1775	CLP-H2-LM	100	A	4÷10	25	75
CLP1780	CLP-H3-LM	100	A	10÷15	25	75
CLP1785	CLP-H4-LM	100	A	15÷20	25	75

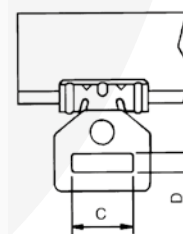
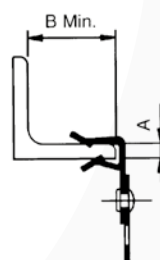
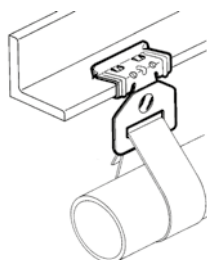

CON PORTA BANDELLA

Codice	Riferimento		F	A (mm)	B (mm)	C x D (mm)	CL (kg)
CLP1550	CLP-H1-PB	100	A	1,5÷4	18	28x6,5	45
CLP1555	CLP-H2-PB	100	A	4÷10	25	28x6,5	45
CLP1560	CLP-H3-PB	100	A	10÷15	25	28x6,5	45
CLP1565	CLP-H4-PB	100	A	15÷20	25	28x6,5	45

Ω CLIP - Clip in acciaio armonico SERIE EASY

Ω CLIP - SERIE EASY

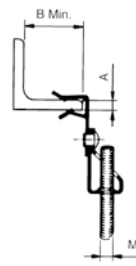
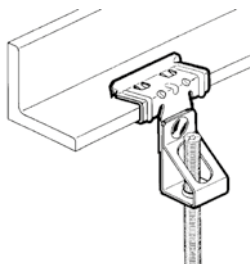

CON PORTA BARRA FILETTATA

Codice	Riferimento		F	A (mm)	B (mm)	M	CL (kg)
CLP1090	CLP-BF1-M6	100	A	1,5÷4	18	M6	70
CLP1095	CLP-BF2-M6	100	A	4÷10	25	M6	70
CLP1100	CLP-BF3-M6	100	A	10÷15	25	M6	70
CLP1105	CLP-BF4-M6	100	A	15÷20	25	M6	70
CLP1120	CLP-BF1-M8	100	A	1,5÷4	18	M8	70
CLP1125	CLP-BF2-M8	100	A	4÷10	25	M8	70
CLP1130	CLP-BF3-M8	100	A	10÷15	25	M8	70
CLP1135	CLP-BF4-M8	100	A	15÷20	25	M8	70
CLP1150	CLP-BF1-M10	100	A	1,5÷4	18	M10	70
CLP1155	CLP-BF2-M10	100	A	4÷10	25	M10	70
CLP1160	CLP-BF3-M10	100	A	10÷15	25	M10	70
CLP1165	CLP-BF4-M10	100	A	15÷20	25	M10	70

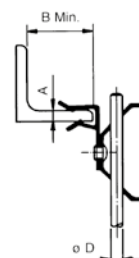
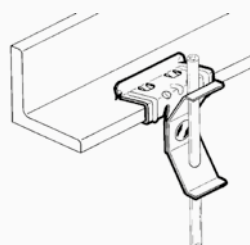

CON MOLLA PER PENDINO

Codice	Riferimento		F	A (mm)	B (mm)	Ø (mm)	CL (kg)
CLP1790	CLP-H1-MP	100	A	1,5÷4	18	6	60
CLP1795	CLP-H2-MP	100	A	4÷10	25	6	60
CLP1800	CLP-H3-MP	100	A	10÷15	25	6	60
CLP1805	CLP-H4-MP	100	A	15÷20	25	6	60

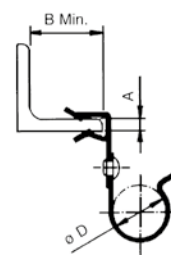
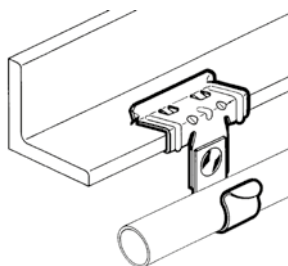

CON FAST CLIP

Codice	Riferimento		F	A (mm)	B (mm)	Ø (mm)
CLP1370	CLP-H1-F1214	100	A	1,5+4	18	12-14
CLP1375	CLP-H1-F1518	100	A	1,5+4	18	15-18
CLP1380	CLP-H1-F1924	100	A	1,5+4	18	19-24
CLP1385	CLP-H1-F2530	100	A	1,5+4	18	25-30
CLP1390	CLP-H2-F1214	100	A	4+10	25	12-14
CLP1395	CLP-H2-F1518	100	A	4+10	25	15-18
CLP1400	CLP-H2-F1924	100	A	4+10	25	19-24
CLP1405	CLP-H2-F2530	100	A	4+10	25	25-30
CLP1410	CLP-H3-F1214	100	A	10+15	25	12-14
CLP1415	CLP-H3-F1518	100	A	10+15	25	15-18
CLP1420	CLP-H3-F1924	100	A	10+15	25	19-24
CLP1425	CLP-H3-F2530	100	A	10+15	25	25-30
CLP1430	CLP-H4-F1214	100	A	15+20	25	12-14
CLP1435	CLP-H4-F1518	100	A	15+20	25	15-18
CLP1440	CLP-H4-F1924	100	A	15+20	25	19-24
CLP1445	CLP-H4-F2530	100	A	15+20	25	25-30

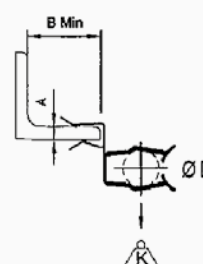
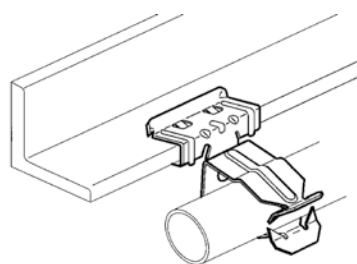

CON FISSATUBO

Codice	Riferimento		F	A (mm)	B (mm)	Ø (mm)
CLP1570	CLP-H1-FT1822	100	A	1,5+4	18	18-22
CLP1575	CLP-H1-FT2230	100	A	1,5+4	18	22-30
CLP1580	CLP-H1-FT3035	100	A	1,5+4	18	30-35
CLP1585	CLP-H2-FT1822	100	A	4+10	25	18-22
CLP1590	CLP-H2-FT2230	100	A	4+10	25	22-30
CLP1595	CLP-H2-FT3035	100	A	4+10	25	30-35
CLP1600	CLP-H3-FT1822	100	A	10+15	25	18-22
CLP1605	CLP-H3-FT2230	100	A	10+15	25	22-30
CLP1610	CLP-H3-FT3035	100	A	10+15	25	30-35
CLP1615	CLP-H4-FT1822	100	A	15+20	25	18-22
CLP1620	CLP-H4-FT2230	100	A	15+20	25	22-30
CLP1625	CLP-H4-FT3035	100	A	15+20	25	30-35

Ω CLIP - Clip in acciaio armonico SERIE FAST

Ω CLIP - SERIE FAST

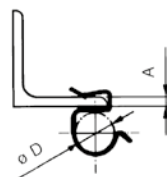
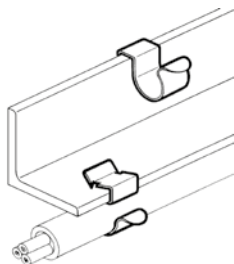

SNAP FISSATUBO

Codice	Riferimento		F	A (mm)	Ø D (mm)
CLP1215	CLP-1C89	100	A	1+4	8-9
CLP1220	CLP-1C1011	100	A	1+4	10-11
CLP1225	CLP-1C1214	100	A	1+4	12-14
CLP1230	CLP-1C1518	100	A	1+4	15-18
CLP1235	CLP-1C1924	100	A	1+4	19-24
CLP1240	CLP-1C2530	100	A	1+4	25-30
CLP1245	CLP-2C89	100	A	4+7,5	8-9
CLP1250	CLP-2C1011	100	A	4+7,5	10-11
CLP1255	CLP-2C1214	100	A	4+7,5	12-14
CLP1260	CLP-2C1518	100	A	4+7,5	15-18
CLP1265	CLP-2C1924	100	A	4+7,5	19-24
CLP1270	CLP-2C2530	100	A	4+7,5	25-30
CLP1275	CLP-3C89	100	A	7,5+12	8-9
CLP1280	CLP-3C1011	100	A	7,5+12	10-11
CLP1285	CLP-3C1214	100	A	7,5+12	12-14
CLP1290	CLP-3C1518	100	A	7,5+12	15-18
CLP1295	CLP-3C1924	100	A	7,5+12	19-24
CLP1300	CLP-3C2530	100	A	7,5+12	25-30

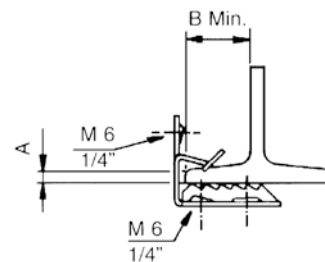
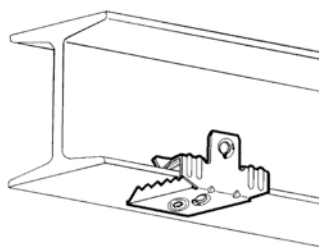

BASE

Codice	Riferimento		F	A (mm)	B (mm)	CL (kg)
CLP1170	CLP-ME2	100	A	4+10	35	45
CLP1175	CLP-ME3	100	A	10+15	35	45
CLP1180	CLP-ME4	100	A	15+20	35	45

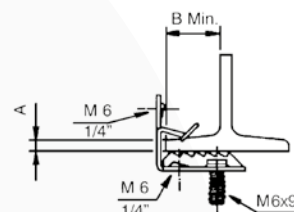
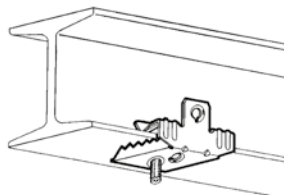

CON VITE M6

Codice	Riferimento		F	A (mm)	B (mm)	CL (kg)
CLP1200	CLP-ME2-V	100	A	4+10	35	33
CLP1205	CLP-ME3-V	100	A	10+15	35	33
CLP1210	CLP-ME4-V	100	A	15+20	35	33

Ω CLIP - Clip in acciaio armonico SERIE MEGA

Ω CLIP - SERIE MEGA

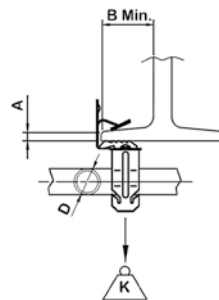
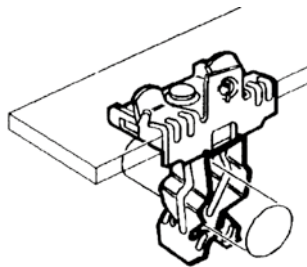
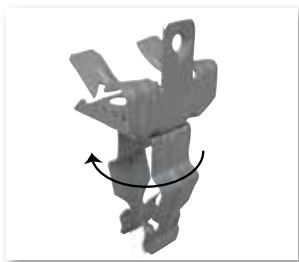

CON FISSATUBO

Codice	Riferimento		F	A (mm)	B (mm)	Ø (mm)	CL (kg)
CLP1660	CLP-ME2-FT1822	100	A	4+10	35	18-22	11
CLP1665	CLP-ME2-FT2230	100	A	4+10	35	22-30	11
CLP1670	CLP-ME2-FT3035	100	A	4+10	35	30-35	11
CLP1675	CLP-ME3-FT1822	100	A	10+15	35	18-22	11
CLP1680	CLP-ME3-FT2230	50	A	10+15	35	22-30	11
CLP1685	CLP-ME3-FT3035	50	A	10+15	35	30-35	11
CLP1690	CLP-ME4-FT1822	50	A	15+20	35	18-22	11
CLP1695	CLP-ME4-FT2230	50	A	15+20	35	22-30	11
CLP1700	CLP-ME4-FT3035	50	A	15+20	35	30-35	11

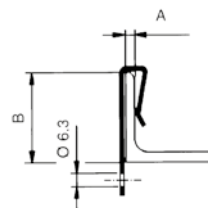
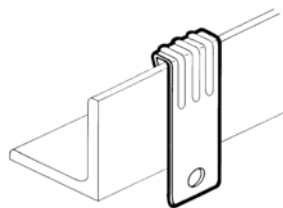

VERTICALE

Codice	Riferimento		F	A (mm)	B (mm)	CL (kg)
CLP1450	CLP-HK1	100	A	1,5÷5	30	70
CLP1455	CLP-HK2	100	A	5÷7	30	70
CLP1465	CLP-HK4	100	A	4÷10	60	70

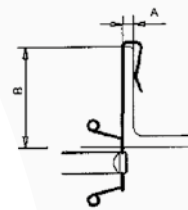
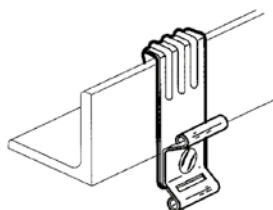

CON PORTAFASCETTA

Codice	Riferimento		F	A (mm)	B (mm)	CL (kg)
CLP1470	CLP-HK1-CT	100	A	1,5÷5	30	70
CLP1475	CLP-HK2-CT	100	A	5÷7	30	70
CLP1485	CLP-HK4-CT	100	A	4÷10	60	70

Ω CLIP - Clip in acciaio armonico SERIE HOOK

Ω CLIP - SERIE HOOK

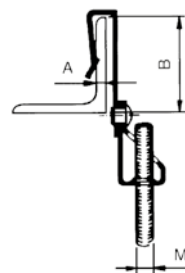
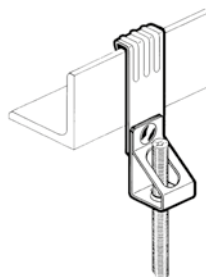

CON PORTA BARRA FILETTATA

Codice	Riferimento		F	A (mm)	B (mm)	M	CL (kg)
CLP1490	CLP-HK1-BF6	100	A	1,5÷5	30	M6	70
CLP1495	CLP-HK2-BF6	100	A	5÷7	30	M6	70
CLP1505	CLP-HK4-BF6	100	A	4÷10	60	M6	70
CLP1510	CLP-HK1-BF8	100	A	1,5÷5	30	M8	70
CLP1515	CLP-HK2-BF8	100	A	5÷7	30	M8	70
CLP1525	CLP-HK4-BF8	100	A	4÷10	60	M8	70
CLP1530	CLP-HK1-BF10	100	A	1,5÷5	30	M10	70
CLP1535	CLP-HK2-BF10	100	A	5÷7	30	M10	70
CLP1545	CLP-HK4-BF10	100	A	4÷10	60	M10	70

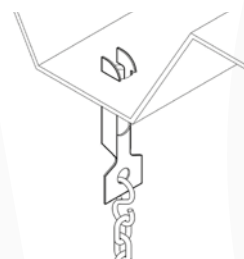
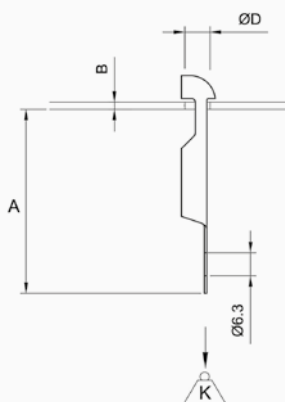

PER LAMIERA GRECCATA - CON FORO

Codice	Riferimento		F	B (mm)	Ø D (mm)	CM (kg)
CLP1820	CLP-HO	100	A	0,8-3	7-8	* vedi nota

* Con lamiera di spessore da 0,8 a 2 mm CM = 45 kg
 Con lamiera di spessore da 2,1 a 3 mm CM = 68 kg

ISTRUZIONI DI MONTAGGIO

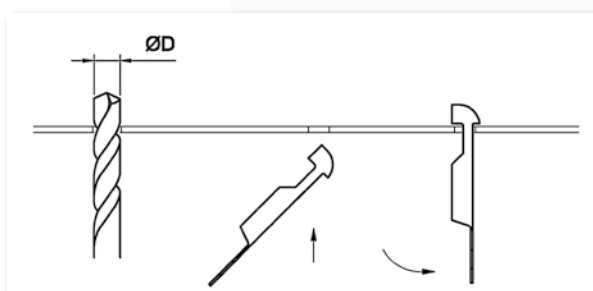

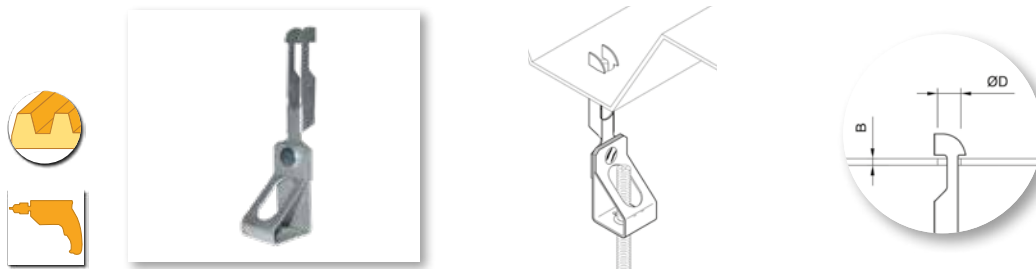

PER LAMIERA GRECATA - PER BARRA FILETTATA

Codice	Riferimento		F	B (mm)	Ø D (mm)	M	CM (kg)
CLP1825	CLP-HO-BF6	100	A	0,8-3	7-8	M 6	* vedi nota
CLP1830	CLP-HO-BF8	100	A	0,8-3	7-8	M 8	* vedi nota
CLP1835	CLP-HO-BF10	100	A	0,8-3	7-8	M 10	* vedi nota

* Con lamiera di spessore da 0,8 a 2 mm CM = 45 kg
 Con lamiera di spessore da 2,1 a 3 mm CM = 68 kg

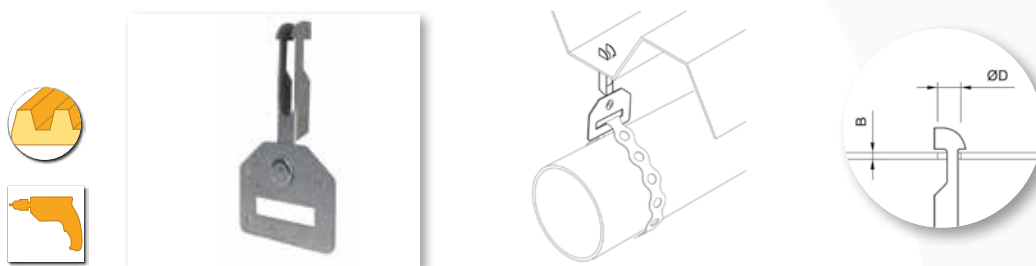

PER LAMIERA GRECATA - PER BANDELLA

Codice	Riferimento		F	B (mm)	Ø D (mm)	Asola (mm)	CM (kg)
CLP1840	CLP-HO-PB	100	A	0,8-3	7-8	28 x 6,5	* vedi nota

* Con lamiera di spessore da 0,8 a 2 mm CM = 45 kg
 Con lamiera di spessore da 2,1 a 3 mm CM = 68 kg

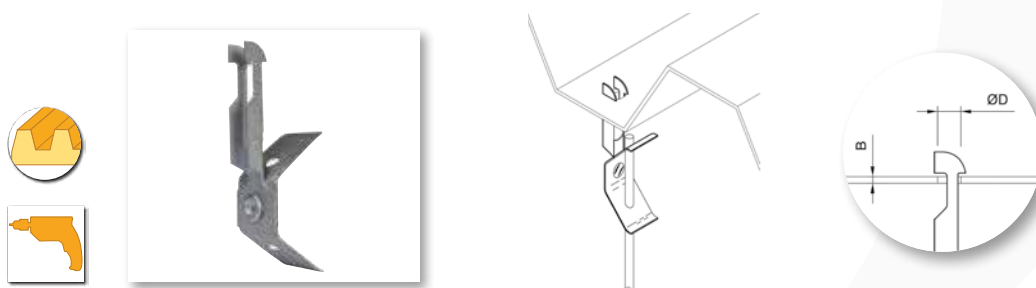

PER LAMIERA GRECATA - PER PENDINO

Codice	Riferimento		F	B (mm)	Ø D (mm)	Ø Pendino (mm)	CM (kg)
CLP1845	CLP-HO-MP4	100	A	0,8-3	7-8	4	* vedi nota
CLP1850	CLP-HO-MP6	100	A	0,8-3	7-8	6	* vedi nota

* Con lamiera di spessore da 0,8 a 2 mm CM = 45 kg
 Con lamiera di spessore da 2,1 a 3 mm CM = 68 kg

Aggancio per profilo a "T" controsoffitto CLIP A ROMBO

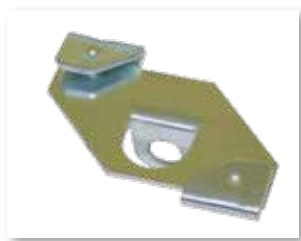

CON OCCHIELLO

Codice	Riferimento		F	A (mm)	Ø (mm)	CL (kg)
CLP1315	CLP-CFE	100	A	25	7	20
CLP1320	CLP-CFL	100	L	25	7	20

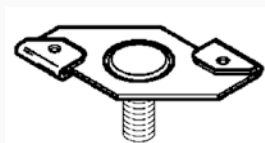

CON VITE

Codice	Riferimento		F	A (mm)	M x L	CL (kg)
CLP1325	CLP-CFM11-E	100	A	25	M6x11	20
CLP1330	CLP-CFM16-E	100	A	25	M6x16	20
CLP1335	CLP-CFM25-E	100	A	25	M6x25	20
CLP1340	CLP-CFM11-L	100	L	25	M6x11	20
CLP1345	CLP-CFM16-L	100	L	25	M6x16	20
CLP1350	CLP-CFM25-L	100	L	25	M6x25	20



RONDELLA ACCIAIO ARMONICO

Codice	Riferimento		F	Ø Est. (mm)	M
CLP1810	CLP-RFP	100	A	33	M6

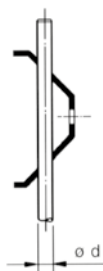
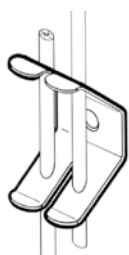

MOLLA PER PENDINO

Codice	Riferimento		F	Ø D (mm)	CM (kg)
CLP1855	CLP-MPD4	100	A	4	30
CLP1860	CLP-MPD6	100	A	6	30

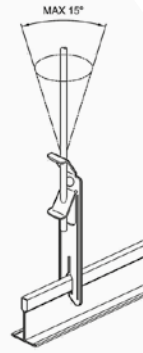
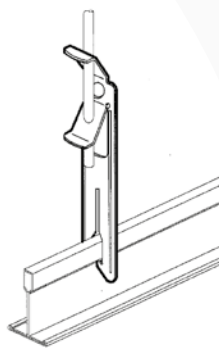
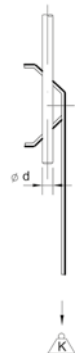

SUPPORTO PROFILO - CARICHI LEGGERI

Codice	Riferimento		F	Ø D (mm)	CM (kg)
CLP1865	CLP-CF-MPL	100	A	4	15

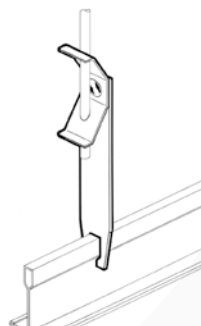

SUPPORTO PROFILO - CARICHI PESANTI

Codice	Riferimento		F	Ø D (mm)	CM (kg)
CLP1870	CLP-CF-MPH4N	100	F	4	45
CLP1875	CLP-CF-MPH6N	100	F	6	45

Ω CLIP - Clip in acciaio armonico SERIE CLAMP

Ω CLIP - SERIE CLAMP

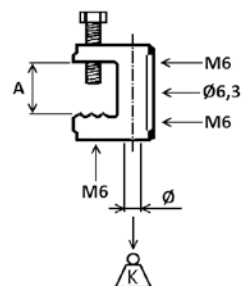
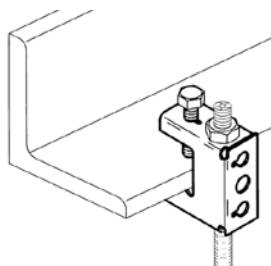

BASE

Codice	Riferimento		F	A (mm)	Ø (mm)	CL (kg)
CLP1305	CLP-MBC	100	A	0÷16	10,5	45

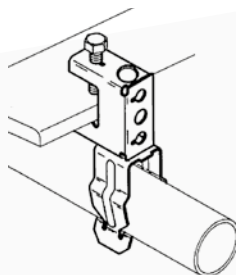

CON FISSATUBO VERTICALE

Codice	Riferimento		F	A (mm)	Ø (mm)	CL (kg)
CLP1630	CLP-MBC-FTV1822	100	A	0÷16	18÷22	11
CLP1635	CLP-MBC-FTV2230	100	A	0÷16	22÷30	11
CLP1640	CLP-MBC-FTV3035	100	A	0÷16	30÷35	11

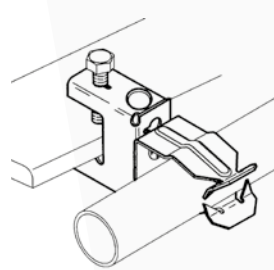
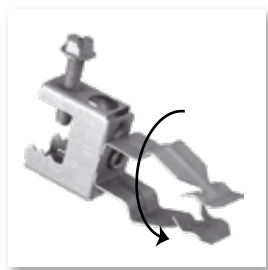

CON FISSATUBO ORIZZONTALE

Codice	Riferimento		F	A (mm)	Ø (mm)	CL (kg)
CLP1645	CLP-MBC-FTO1822	100	A	0÷16	18÷22	7
CLP1650	CLP-MBC-FTO2230	100	A	0÷16	22÷30	7
CLP1655	CLP-MBC-FTO3035	100	A	0÷16	30÷35	7

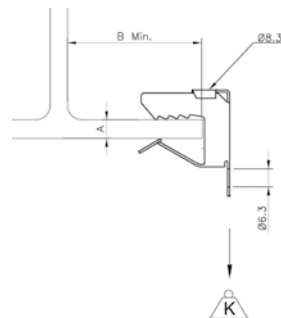
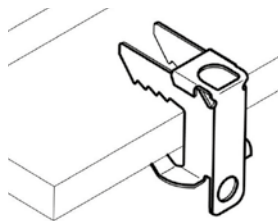

MORSETTO SENZA VITE

Codice	Riferimento		F	A (mm)	B (mm)	CL (kg)
CLP2100	CLP- QJ1	100	A	3-8	25	120
CLP2105	CLP- QJ2	100	A	8-14	25	120
CLP2110	CLP- QJ3	100	A	14-20	25	120

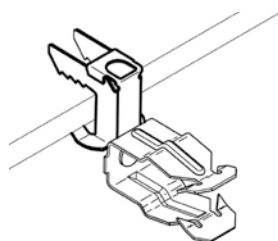

CON FISSATUBO ORIZZONTALE

Codice	Riferimento		F	A (mm)	B (mm)	Ø (mm)
CLP2000	CLP- QJ1-FT01822	100	A	3-8	25	18-22
CLP2005	CLP- QJ1-FT02230	100	A	3-8	25	22-30
CLP2010	CLP- QJ1-FT03035	100	A	3-8	25	30-35
CLP2015	CLP- QJ2- FT01822	100	A	8-14	25	18-22
CLP2020	CLP- QJ2- FT02230	100	A	8-14	25	22-30
CLP2025	CLP- QJ2- FT03035	100	A	8-14	25	30-35
CLP2030	CLP- QJ3- FT01822	100	A	14-20	25	18-22
CLP2035	CLP- QJ3- FT02230	100	A	14-20	25	22-30
CLP2040	CLP- QJ3- FT03035	100	A	14-20	25	30-35

APPLICAZIONI

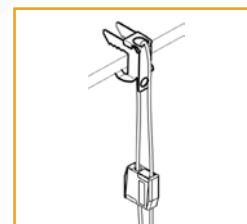
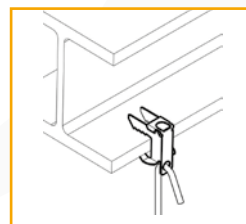
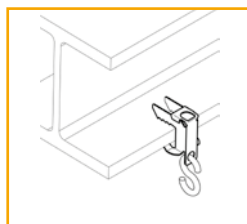
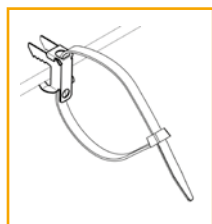
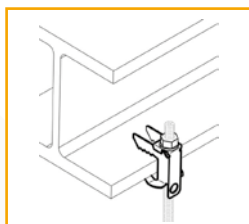



CLP1720
vite di fissaggio

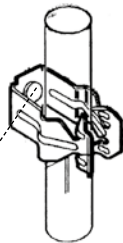

FISSATUBO

Codice	Riferimento		F	Ø (mm)	CL (kg)
CLP1705	CLP-FT1822	100	A	18-22	11
CLP1710	CLP-FT2230	100	A	22-30	11
CLP1715	CLP-FT3035	100	A	30-35	11
CLP1720*	CLP-VDM6	100	E		

* Vite M6 compresa di dado

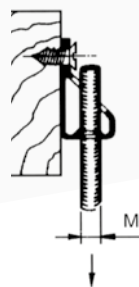
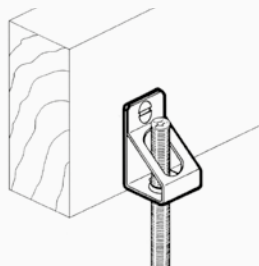

PER BARRA FILETTATA

Codice	Riferimento		F	M	CL (kg)
CLP1915	CLP-BF-M6	100	A	M6	70
CLP1920	CLP-BF-M8	100	A	M8	70
CLP1925	CLP-BF-M10	100	A	M10	70

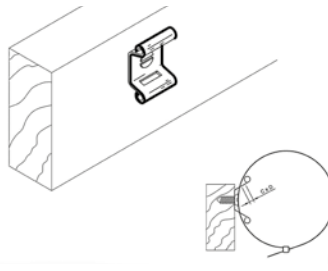

PORTA FASCETTA

Codice	Riferimento		F	C x D (mm)	CL (kg)
CLP1930	CLP-CT	100	A	3 x 10	15

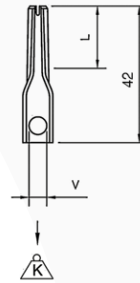
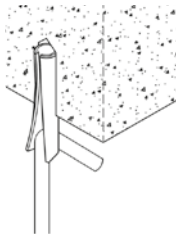

TASSELLO A BATTERE

Codice	Riferimento		F	Ø V (mm)	L min (mm)	Ø D (mm)	CL (kg)
CLP1815	CLP-TP4	100	F	4	20	8	40

ISTRUZIONI DI MONTAGGIO

Utilizzabile su cemento armato precompresso, calcestruzzo o mattoni pieni.

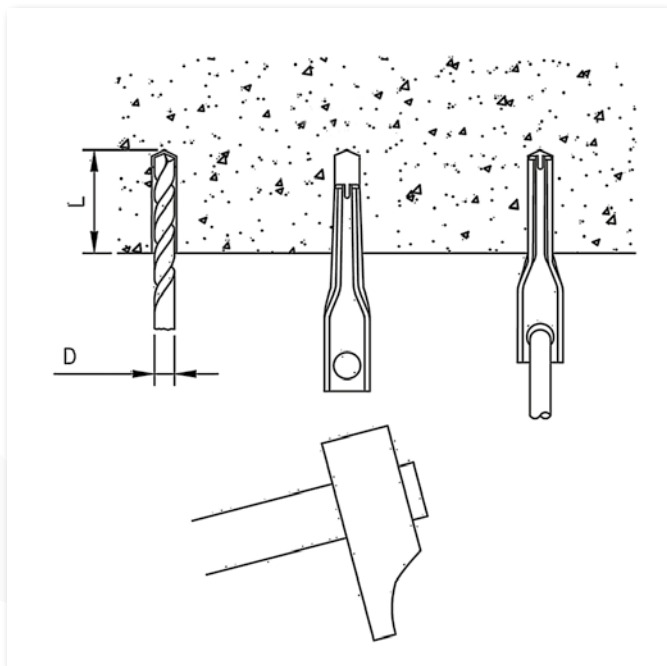



Ω STRUT - Profilati Staffe e Mensole

Caratteristiche del prodotto

La posa delle canalizzazioni porta cavi, rappresenta una delle più dispendiose voci per chi è alle prese con l'installazione elettrica industriale.

Per questo è nata la necessità di creare Sistemi di Fissaggio alternativi, orientati alla semplicità e rapidità di montaggio. Stimolata dai progressi registrati nel nord Europa, un mercato spesso più dinamico del nostro, Teknomega si è messa alla ricerca di soluzioni innovative rivolte a dare risposte sempre più elastiche alle richieste ed alle esigenze della moderna impiantistica.

Ω STRUT

Ancora oggi i Sistemi di Fissaggio non vengono adeguatamente considerati nell'impiantistica industriale. La loro enorme incidenza in termini di costo, viene soppesata soltanto a lavori ultimati, quando cioè è troppo tardi per correre ai ripari.

Se invece ci si affida a collaudati specialisti in fase di progettazione, evitando di utilizzare staffaggi pensati e realizzati senza la minima competenza tecnica, tutte le problematiche risulteranno di facile risoluzione.

Specialisti come Teknomega, guidano l'installatore verso la più efficace delle soluzioni, come quella proposta dalla famiglia "Ω STRUT". Questa gamma è composta da una serie di prodotti complementari tra loro: profilati, mensole di vari tipi e staffe di connessione, che quasi come in un "Meccano", realizzano vere e proprie strutture di fissaggio rapido e sicuro. Un'ulteriore peculiarità della gamma "Ω STRUT", è rappresentata dalla grande versatilità degli accessori, quali collari, barre filettate, catenelle e sospensioni a cavetto metallico, che possono essere installate su strutture portanti in cemento o in putrella metallica.

NB: I profili Sendzmir, a richiesta e compatibilmente con i quantitativi richiesti, possono essere forniti con finitura verniciata a polvere.

41x41 doppio Sp. 2,5 mm - Asolato

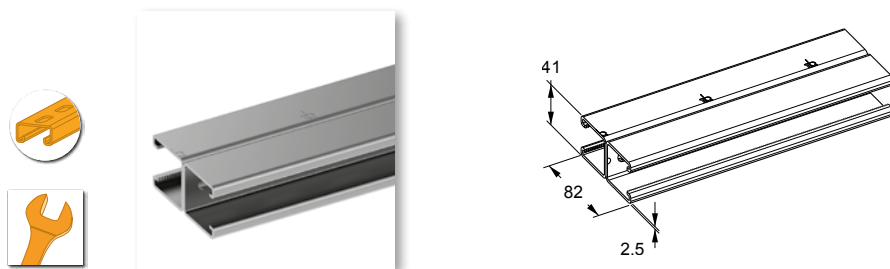

SENDZIMIR

Codice	Riferimento	F	L (m)	Peso (kg)	Asola profilo (mm)	Inter. asola (mm)		
PRF1085	PRF-A3D-SF	S	3	15,60	30x11	50	1	14
PRF1090	PRF-A4D-SF	S	4	20,80	30x11	50	1	14
PRF1095*	PRF-A6D-SF	S	6	31,20	30x11	50	1	14

ZINCATO A CALDO

Codice	Riferimento	F	L (m)	Peso (kg)	Asola profilo (mm)	Inter. asola (mm)		
PRF1105	PRF-A3D-ZF	Z	3	15,60	30x11	50	1	14
PRF1110	PRF-A4D-ZF	Z	4	20,80	30x11	50	1	14
PRF1115*	PRF-A6D-ZF	Z	6	31,20	30x11	50	1	14

* su richiesta

41x21 doppio Sp. 2,5 mm - Asolato

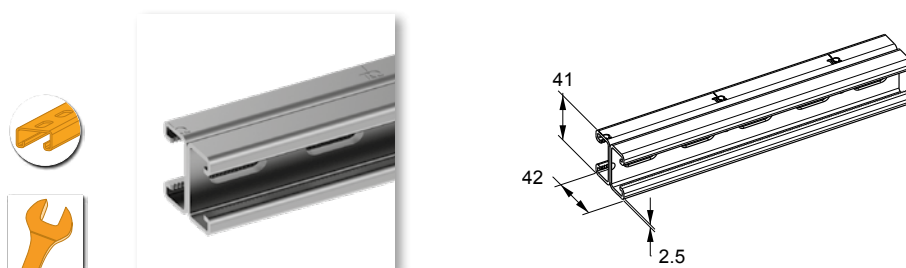

SENDZIMIR

Codice	Riferimento	F	L (m)	Peso (kg)	Asola profilo (mm)	Inter. asola (mm)		
PRF1275	PRF-B3D-S	S	3	10,40	30x11	50	1	30
PRF1280	PRF-B4D-S	S	4	13,90	30x11	50	1	30
PRF1285*	PRF-B6D-S	S	6	20,80	30x11	50	1	30

ZINCATO A CALDO



Codice	Riferimento	F	L (m)	Peso (kg)	Asola profilo (mm)	Inter. asola (mm)		
PRF1295	PRF-B3D-Z	Z	3	10,40	30x11	50	1	30
PRF1300	PRF-B4D-Z	Z	4	13,90	30x11	50	1	30
PRF1305*	PRF-B6D-Z	Z	6	20,80	30x11	50	1	30

* su richiesta

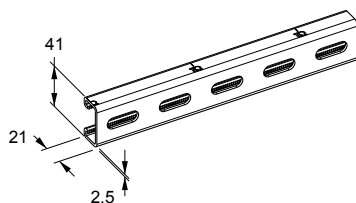
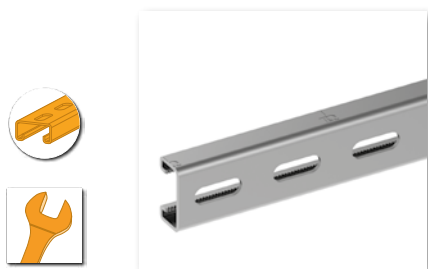

41x21 Sp. 2,5 mm - Asolato



SENDZIMIR

Codice	Riferimento	F	L (m)	Peso (kg)	Asola profilo (mm)	Inter. asola (mm)		
PRF1125	PRF-B3-SF	S	3	5,1	30x11	50	1	30
PRF1130	PRF-B4-SF	S	4	6,8	30x11	50	1	30
PRF1135*	PRF-B6-SF	S	6	10,2	30x11	50	1	30

ZINCATO A CALDO



Codice	Riferimento	F	L (m)	Peso (kg)	Asola profilo (mm)	Inter. asola (mm)		
PRF1145	PRF-B3-ZF	Z	3	5,1	30x11	50	1	30
PRF1150	PRF-B4-ZF	Z	4	6,8	30x11	50	1	30
PRF1155*	PRF-B6-ZF	Z	6	10,2	30x11	50	1	30

* su richiesta

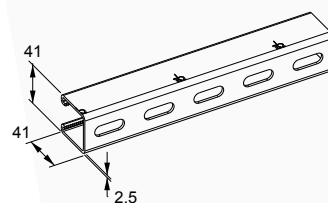

41x41 Sp. 2,5 mm - Asolato



SENDZIMIR

Codice	Riferimento	F	L (m)	Peso (kg)	Asola profilo (mm)	Inter. asola (mm)		
PRF1165	PRF-A3-SF	S	3	7,7	30x11	50	1	30
PRF1170	PRF-A4-SF	S	4	10,2	30x11	50	1	30
PRF1175*	PRF-A6-SF	S	6	15,3	30x11	50	1	30

ZINCATO A CALDO

Codice	Riferimento	F	L (m)	Peso (kg)	Asola profilo (mm)	Inter. asola (mm)		
PRF1185	PRF-A3-ZF	Z	3	7,7	30x11	50	1	30
PRF1190	PRF-A4-ZF	Z	4	10,2	30x11	50	1	30
PRF1195*	PRF-A6-ZF	Z	6	15,3	30x11	50	1	30

* su richiesta

41x41 Sp. 2,5 mm - Asolato 3 lati

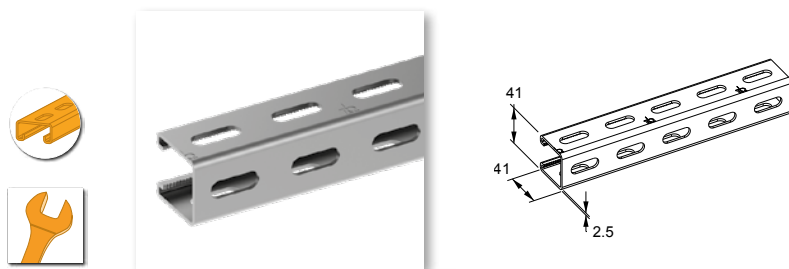

SENDZIMIR

Codice	Riferimento	F	L (m)	Peso (kg)	Asola profilo (mm)	Inter. asola (mm)		
PRF1205	PRF-A3-SF3	S	3	7,5	30x11	50	1	30
PRF1210	PRF-A4-SF3	S	4	10,0	30x11	50	1	30
PRF1215*	PRF-A6-SF3	S	6	15,0	30x11	50	1	30

ZINCATO A CALDO

Codice	Riferimento	F	L (m)	Peso (kg)	Asola profilo (mm)	Inter. asola (mm)		
PRF1225	PRF-A3-ZF3	Z	3	7,5	30x11	50	1	30
PRF1230	PRF-A4-ZF3	Z	4	10,0	30x11	50	1	30
PRF1235*	PRF-A6-ZF3	Z	6	15,0	30x11	50	1	30

* su richiesta

41x21 Sp. 2 mm - Asolato

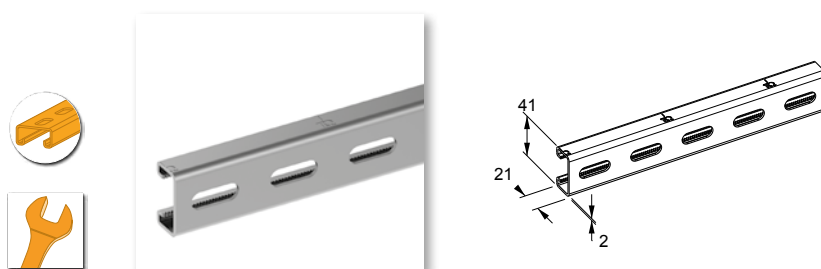

SENDZIMIR

Codice	Riferimento	F	L (m)	Peso (kg)	Asola profilo (mm)	Inter. asola (mm)		
PRF1500	PRF-RB3-SF	S	3	4,3	30x11	50	1	30
PRF1505	PRF-RB4-SF	S	4	5,7	30x11	50	1	30
PRF1510*	PRF-RB6-SF	S	6	8,6	30x11	50	1	30

ZINCATO A CALDO



Codice	Riferimento	F	L (m)	Peso (kg)	Asola profilo (mm)	Inter. asola (mm)		
PRF1515	PRF-RB3-ZF	Z	3	4,3	30x11	50	1	30
PRF1520	PRF-RB4-ZF	Z	4	5,7	30x11	50	1	30
PRF1525*	PRF-RB6-ZF	Z	6	8,6	30x11	50	1	30

* su richiesta

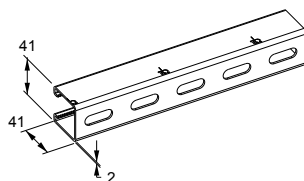

41x41 Sp. 2 mm - Asolato



SENDZIMIR

Codice	Riferimento	F	L (m)	Peso (kg)	Asola profilo (mm)	Inter. asola (mm)		
PRF1530	PRF-RA3-SF	S	3	6,2	30x11	50	1	30
PRF1535	PRF-RA4-SF	S	4	8,2	30x11	50	1	30
PRF1540*	PRF-RA6-SF	S	6	12,4	30x11	50	1	30

ZINCATO A CALDO



Codice	Riferimento	F	L (m)	Peso (kg)	Asola profilo (mm)	Inter. asola (mm)		
PRF1545	PRF-RA3-ZF	Z	3	6,2	30x11	50	1	30
PRF1550	PRF-RA4-ZF	Z	4	8,2	30x11	50	1	30
PRF1555*	PRF-RA6-ZF	Z	6	12,4	30x11	50	1	30

* su richiesta

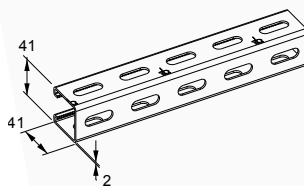

41x41 Sp. 2 mm - Asolato 3 lati



SENDZIMIR

Codice	Riferimento	F	L (m)	Peso (kg)	Asola profilo (mm)	Inter. asola (mm)		
PRF1560	PRF-RA3-SF3	S	3	5,6	30x11	50	1	30
PRF1565	PRF-RA4-SF3	S	4	7,5	30x11	50	1	30
PRF1570*	PRF-RA6-SF3	S	6	11,2	30x11	50	1	30

ZINCATO A CALDO

Codice	Riferimento	F	L (m)	Peso (kg)	Asola profilo (mm)	Inter. asola (mm)		
PRF1575	PRF-RA3-ZF3	Z	3	5,6	30x11	50	1	30
PRF1580	PRF-RA4-ZF3	Z	4	7,5	30x11	50	1	30
PRF1585*	PRF-RA6-ZF3	Z	6	11,2	30x11	50	1	30

* su richiesta



MAGNELIS®

Una nuova soluzione anti-corrosione studiata per offrire la massima protezione anche in ambienti particolarmente aggressivi



Il trattamento anti corrosione Magnelis® è ottenuto in un bagno di metallo fuso composto da: zinco, alluminio oltre ad una percentuale pari al 3% di magnesio, che crea uno strato ad alta resistenza alla corrosione che ricopre l'intera superficie. La finitura risulta di colore grigio scuro uniforme, liscia e priva delle imperfezioni tipiche della zincatura a caldo; Magnelis® è un'ottima alternativa alla zincatura dopo lavorazione, o all'utilizzo di alluminio e acciaio inox. Lo strato di Magnelis® è "auto rigenerante" e protegge graffi e tagli o forature eseguite dopo lavorazione. Ottima anche la resistenza in ambienti carichi di cloro ed ammoniaca. Magnelis® assicura inoltre una protezione di durata eccezionale contro la prima corrosione: tests effettuati in nebbia salina per circa otto mesi hanno messo in evidenza la netta superiorità del Magnelis® rispetto a zincatura elettrolitica, a caldo, Aluzinc etc. Inoltre, grazie alla sua duttilità, Magnelis® consente la "formatura" ottenuta con i tradizionali metodi di lavorazione a freddo come piegatura, stampaggio e profilatura.

Per ulteriori informazioni tecniche Vi preghiamo di contattare i nostri uffici

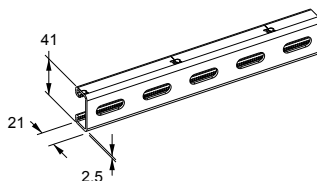
41x21 Sp. 2,5 mm - Asolato





MAGNELIS®

Codice	Riferimento	F	L (m)	Peso (kg)	Asola profilo (mm)	Inter. asola (mm)		
PRF2000	PRF-B3-MF3	M	3	5,1	30x11	50	1	30

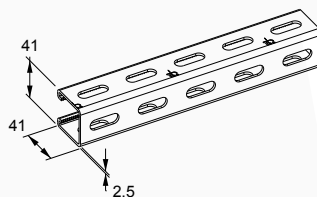
41x41 Sp. 2,5 mm - Asolato 3 lati



MAGNELIS®

Codice	Riferimento	F	L (m)	Peso (kg)	Asola profilo (mm)	Inter. asola (mm)		
PRF2100	PRF-A3-MF3	M	3	7,5	30x11	50	1	30

41x21 Sp. 1,5 mm - Asolato

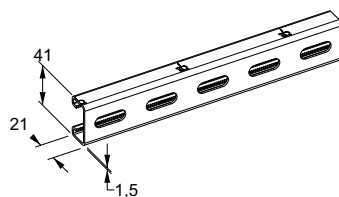

MAGNELIS®

Codice	Riferimento	F	Sp (mm)	L (m)	Peso (kg)	Asola profilo (mm)	Inter. asola (mm)		
PRF2200	PRF-LB3-MF	M	1,5	3	3,2	30x11	50	1	30

41x41 Sp. 1,5 mm - Asolato 3 lati

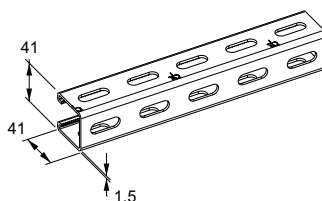

MAGNELIS®

Codice	Riferimento	F	Sp (mm)	L (m)	Peso (kg)	Asola profilo (mm)	Inter. asola (mm)		
PRF2250	PRF-LA3-MF	M	1,5	3	4,2	30x11	50	1	30

41x21 Sp. 2 mm - Forato sul fondo

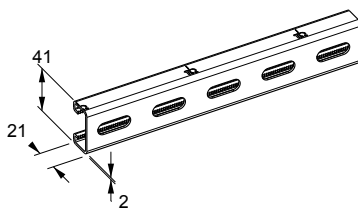

ACCIAIO INOX

Codice	Riferimento	F	L (m)	Peso (kg)	Asola profilo (mm)	Inter. asola (mm)		
PRF9004	PRF-B3-SSF	SS	3	4,4	20x11	50	1	30

41x41 Sp. 2 mm - Forato sul fondo

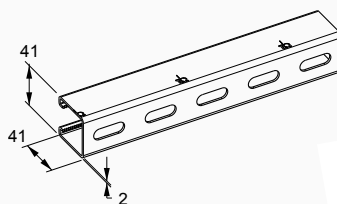

ACCIAIO INOX

Codice	Riferimento	F	L (m)	Peso (kg)	Asola profilo (mm)	Inter. asola (mm)		
PRF9000	PRF-A3-SSF	SS	3	6,2	20x11	50	1	30

GIUNTI PER PROFILO

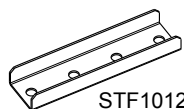

STF1012

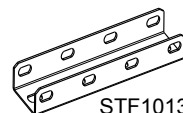

STF1013

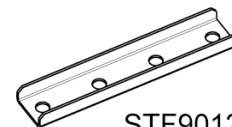

STF9012

ACCIAIO INOX

Codice	Riferimento	Da utilizzare per	F	
STF1012	STF-GI-PB-Inox	41x21	SS	20
STF1013	STF-GI-PA-Inox	41x41	SS	20
STF9012	STF-GI-PD-Inox	41x41 doppio	SS	20

ESEMPI DI MONTAGGIO

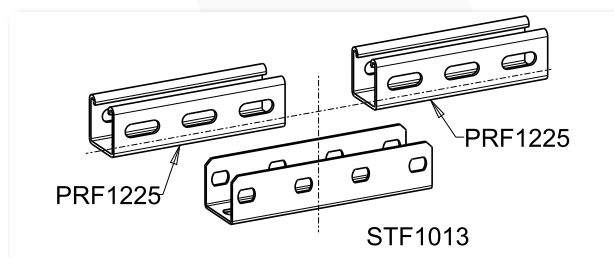
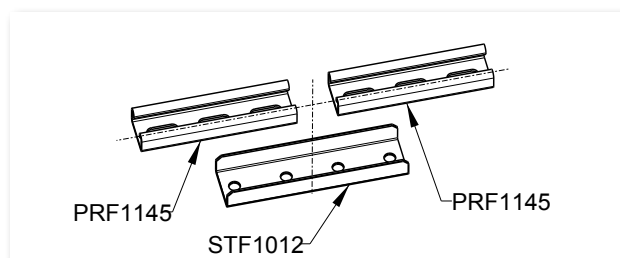

NOTE TECNICHE PER LA ZINCATURA A CALDO

La zincatura a caldo è uno dei metodi migliori per la protezione dei manufatti in acciaio.

Con la zincatura a caldo si realizza sia una protezione con effetto barriera sia una protezione galvanica.

La corrosione nel tempo dello strato protettivo di zinco è influenzata principalmente dalla durata dell'esposizione all'umidità e dalla contaminazione superficiale.

I prodotti con finitura superficiale zincata a caldo, sono realizzati in osservanza dei requisiti tecnici e delle norme internazionali seguenti:

UNI EN ISO 1461: Zincatura a Caldo – specifiche e metodi di prova.

UNI EN ISO 14713: Zincatura a Caldo – linee guida.

Le tabelle seguenti, estratte dalla norma UNI EN ISO 1461 rappresentano gli spessori minimi ottenibili e la durata tipica per i manufatti in acciaio protetti dal trattamento di zincatura a caldo

Articolo e suo spessore	Spessore medio del rivestimento (minimo) [µm]
Acciaio ≥ 6 mm	85
Acciaio ≥ 3 mm fino a < 6 mm	70
Acciaio ≥ 1,5 mm fino a < 3 mm	55
Acciaio < 1,5 mm	45

Codice	Classe di corrosività	Perdita spessore di zinco [µm/anno]
C1	ambiente interno asciutto	≤ 0,1
C2	area rurale esposta nell'entroterra	da 0,1 a 0,7
C3	area entroterra urbana	da 0,7 a 2
C4	area industriale o costiera urbana	da 2 a 4
C5	area industriale con alta umidità o area costiera fronte mare/offshore	da 4 a 8

Profili in acciaio zincato

Materiale: Acciaio FeP02 zincato UNI EN 10111-2008		
Peso specifico	78,5	KN/m ³
Modulo di elasticità longitudinale	210000	N/mm ²
Modulo di elasticità tangenziale	79000	N/mm ²
Coefficiente dilatazione termica lineare	1,2*10 ⁻⁵	1/°C
Resistenza al limite ultimo fy	-	N/mm ²
Resistenza al limite di snervamento fy	430	N/mm ²
Resistenza al limite elastico f0,2	190	N/mm ²

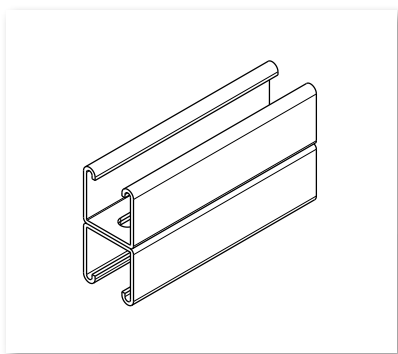

PROFILO 41x41x2,5 mm doppio - Asolato sul fondo			
Caratteristiche meccaniche			
Area della sezione	A	608,88	mm ²
Peso al metro lineare	pp	4,78	daN/m
Momento d'inerzia X	Jx	359936,00	mm ⁴
Momento d'inerzia Y	Jy	180906,51	mm ⁴
Momento resistente X	Wx	8778,93	mm ³
Momento resistente Y	Wy	4412,35	mm ³
Raggio d'inerzia X	ix	24,31	mm
Raggio d'inerzia Y	iy	17,24	mm



Tabella dei carichi ammissibili (con Fmax < L/250)		
Lunghezza trave L (mm)	Carico unif. Distrib. (daN/m)	Carico concentrato in mezzzeria (daN)
500	5337,59	1334,40
1000	1334,4	667,20
2000	290,25	333,60
3000	86,00	161,25
4000	36,28	90,70
5000	18,58	58,05
6000	10,75	40,31



PROFILO doppio 41x21x2,5 mm doppio - Asolato sul fondo			
Caratteristiche meccaniche			
Area della sezione	A	408,88	mm ²
Peso al metro lineare	pp	3,21	daN/m
Momento d'inerzia X	Jx	61187,85	mm ⁴
Momento d'inerzia Y	Jy	106689,85	mm ⁴
Momento resistente X	Wx	2913,71	mm ³
Momento resistente Y	Wy	5080,47	mm ³
Raggio d'inerzia X	ix	12,23	mm
Raggio d'inerzia Y	iy	16,15	mm

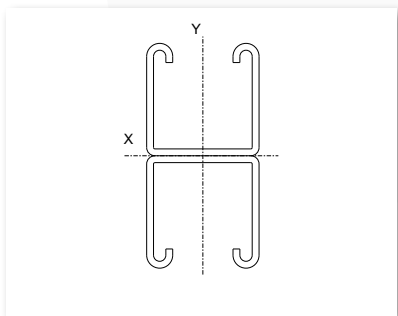
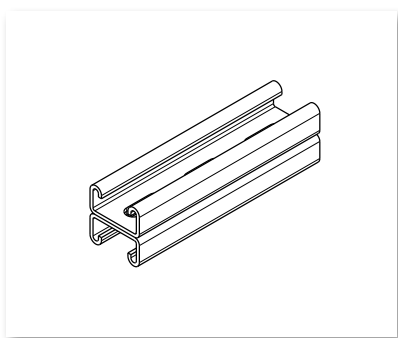

Tabella dei carichi ammissibili (con Fmax < L/250)		
Lunghezza trave L (mm)	Carico unif. Distrib. (daN/m)	Carico concentrato in mezzzeria (daN)
500	1771,53	442,88
750	787,35	295,26
1000	394,74	221,44
1250	202,10	157,89
1500	116,96	109,65
1750	73,65	80,56
2000	49,34	61,68

Profili in acciaio zincato

Materiale: Acciaio FePO2 zincato UNI EN 10111-2008

Peso specifico	78,5	KN/m ³
Modulo di elasticità longitudinale	210000	N/mm ²
Modulo di elasticità tangenziale	79000	N/mm ²
Coefficiente dilatazione termica lineare	1,2*10 ⁻⁵	1/°C
Resistenza al limite ultimo fy	-	N/mm ²
Resistenza al limite di snervamento fy	430	N/mm ²
Resistenza al limite elastico f0,2	190	N/mm ²

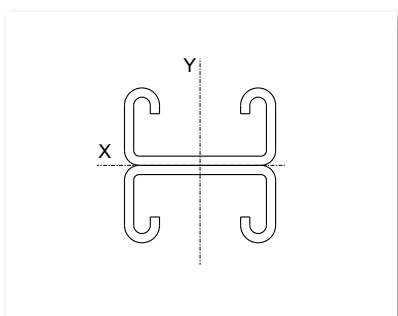
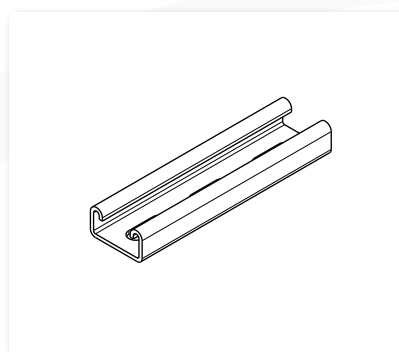

PROFILO 41x21x2,5 mm - Asolato sul fondo			
Caratteristiche meccaniche			
Area della sezione	A	204,44	mm ²
Peso al metro lineare	pp	1,60	daN/m
Momento d'inerzia X	Jx	11295,41	mm ⁴
Momento d'inerzia Y	Jy	53344,92	mm ⁴
Momento resistente X	Wx	10000,99	mm ³
Momento resistente Y	Wy	2602,19	mm ³
Raggio d'inerzia X	ix	7,43	mm
Raggio d'inerzia Y	iy	16,15	mm



Tabella dei carichi ammissibili (con Fmax < L/250)		
Lunghezza trave L (mm)	Carico unif. Distrib. (daN/m)	Carico concentrato in mezzzeria (daN)
500	582,95	152,15
750	172,73	80,97
1000	72,87	45,54
1250	37,31	29,15
1500	21,59	20,24
1750	13,60	14,87
2000	9,11	11,39



PROFILO 41x41x2,5 mm - Asolato sul fondo			
Caratteristiche meccaniche			
Area della sezione	A	304,44	mm ²
Peso al metro lineare	pp	2,39	daN/m
Momento d'inerzia X	Jx	63108,85	mm ⁴
Momento d'inerzia Y	Jy	90453,26	mm ⁴
Momento resistente X	Wx	2947,91	mm ³
Momento resistente Y	Wy	4225,21	mm ³
Raggio d'inerzia X	ix	14,40	mm
Raggio d'inerzia Y	iy	17,24	mm

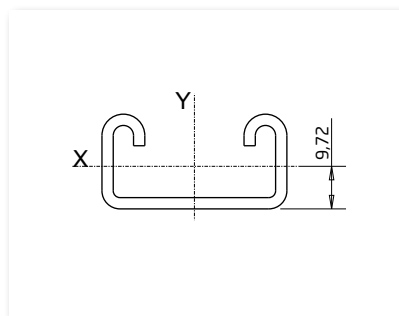
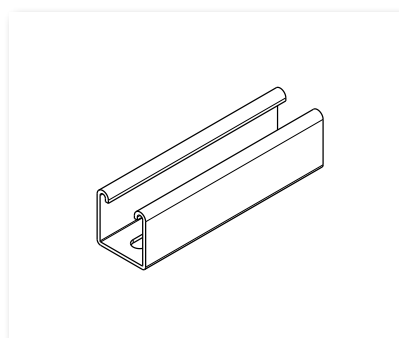

Tabella dei carichi ammissibili (con Fmax < L/250)		
Lunghezza trave L (mm)	Carico unif. Distrib. (daN/m)	Carico concentrato in mezzzeria (daN)
500	1792,33	448,08
750	786,59	298,72
1000	407,13	224,04
1250	208,45	162,85
1500	120,63	113,09
1750	75,97	83,09
2000	50,89	63,61

Profili in acciaio zincato

Materiale: Acciaio FeP02 zincato UNI EN 10111-2008		
Peso specifico	78,5	KN/m ³
Modulo di elasticità longitudinale	210000	N/mm ²
Modulo di elasticità tangenziale	79000	N/mm ²
Coefficiente dilatazione termica lineare	1,2*10 ⁻⁵	1/°C
Resistenza al limite ultimo fy	-	N/mm ²
Resistenza al limite di snervamento fy	430	N/mm ²
Resistenza al limite elastico f0,2	190	N/mm ²

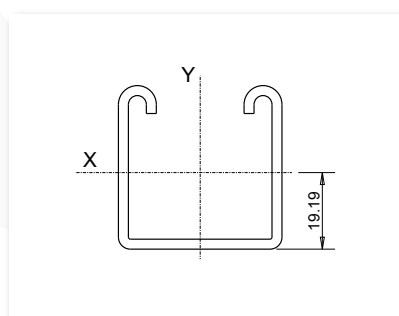
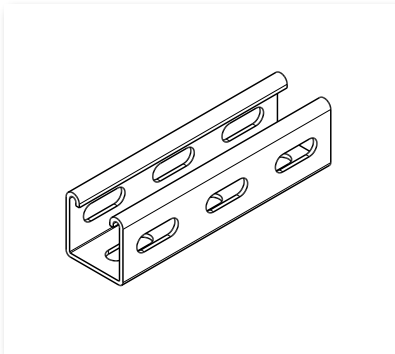

PROFILO 41x41x2,5 mm - Asolato su tre lati			
Caratteristiche meccaniche			
Area della sezione	A	249,44	mm ²
Peso al metro lineare	pp	1,96	daN/m
Momento d'inerzia X	Jx	62498,93	mm ⁴
Momento d'inerzia Y	Jy	70043,67	mm ⁴
Momento resistente X	Wx	2892,37	mm ³
Momento resistente Y	Wy	3241,53	mm ³
Raggio d'inerzia X	ix	15,83	mm
Raggio d'inerzia Y	iy	16,76	mm



Tabella dei carichi ammissibili (con Fmax < U/250)		
Lunghezza trave L (mm)	Carico unif. Distrib. (daN/m)	Carico concentrato in mezzeria (daN)
500	1758,56	439,64
750	781,58	293,09
1000	403,19	219,82
1250	206,43	161,28
1500	119,46	112,00
1750	75,23	82,28
2000	50,40	63,00



PROFILO 41x21x2 mm - Asolato			
Caratteristiche meccaniche			
Area della sezione	A	170,84	mm ²
Peso al metro lineare	pp	1,34	daN/m
Momento d'inerzia X	Jx	10000,81	mm ⁴
Momento d'inerzia Y	Jy	45364,89	mm ⁴
Momento resistente X	Wx	8959,94	mm ³
Momento resistente Y	Wy	2212,92	mm ³
Raggio d'inerzia X	ix	24,19	mm
Raggio d'inerzia Y	iy	16,30	mm

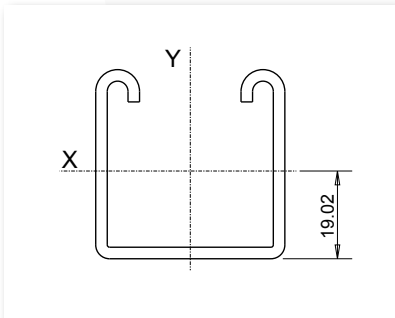
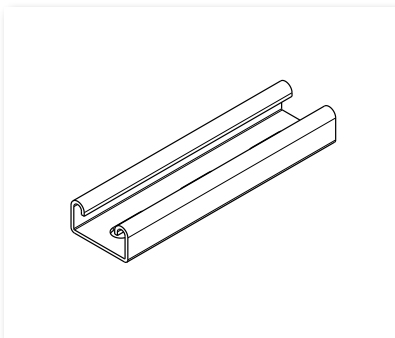

Tabella dei carichi ammissibili (con Fmax < U/250)		
Lunghezza trave L (mm)	Carico unif. Distrib. (daN/m)	Carico concentrato in mezzeria (daN)
500	516,14	136,19
750	152,93	71,69
1000	64,52	40,32
1250	33,03	25,81
1500	19,12	17,92
1750	12,04	13,17
2000	8,06	10,08

Profili in acciaio zincato

Materiale: Acciaio FeP02 zincato UNI EN 10111-2008

Peso specifico	78,5	KN/m ³
Modulo di elasticità longitudinale	210000	N/mm ²
Modulo di elasticità tangenziale	79000	N/mm ²
Coeff. dilatazione termica lineare	1,2*10 ⁻⁵	1/°C
Resistenza al limite ultimo fy	-	N/mm ²
Resistenza al limite di snervamento fy	430	N/mm ²
Resistenza al limite elastico f _{0,2}	190	N/mm ²

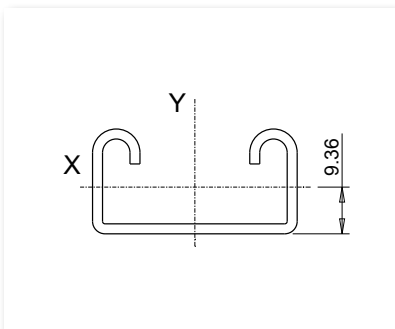
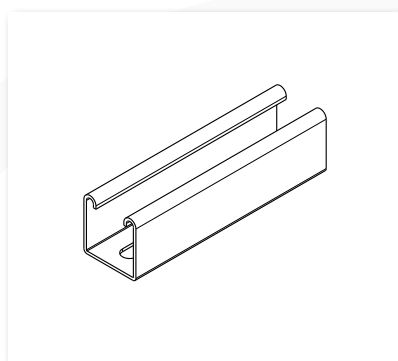

PROFILO 41x41x2 mm - Asolato sul fondo			
Caratteristiche meccaniche			
Area della sezione	A	250,84	mm ²
Peso al metro lineare	pp	1,97	daN/m
Momento d'inerzia X	Jx	53935,51	mm ⁴
Momento d'inerzia Y	Jy	75811,55	mm ⁴
Momento resistente X	Wx	2541,24	mm ³
Momento resistente Y	Wy	3571,96	mm ³
Raggio d'inerzia X	ix	14,66	mm
Raggio d'inerzia Y	iy	17,38	mm



Tabella dei carichi ammissibili (con Fmax < L/250)		
Lunghezza trave L (mm)	Carico unif. Distrib. (daN/m)	Carico concentrato in mezzzeria (daN)
500	1545,07	386,27
750	686,70	257,51
1000	347,70	193,13
1250	178,15	139,18
1500	103,10	96,65
1750	64,92	71,01
2000	43,49	54,37



PROFILO 41x41x2 mm - Asolato su tre lati			
Caratteristiche meccaniche			
Area della sezione	A	206,84	mm ²
Peso al metro lineare	pp	1,62	daN/m
Momento d'inerzia X	Jx	53463,86	mm ⁴
Momento d'inerzia Y	Jy	59065,89	mm ⁴
Momento resistente X	Wx	2500,87	mm ³
Momento resistente Y	Wy	2762,92	mm ³
Raggio d'inerzia X	ix	16,08	mm
Raggio d'inerzia Y	iy	16,90	mm

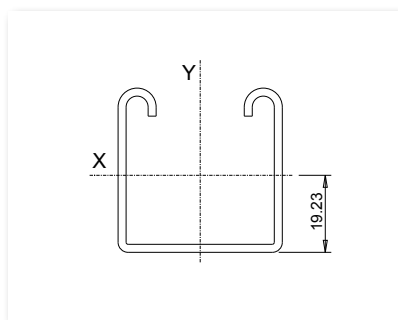
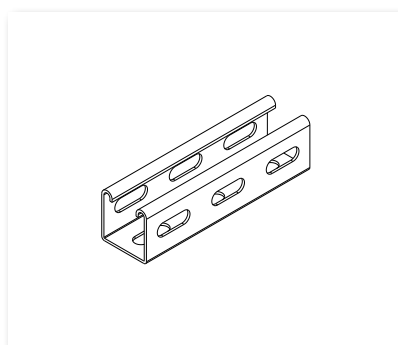

Tabella dei carichi ammissibili (con Fmax < L/250)		
Lunghezza trave L (mm)	Carico unif. Distrib. (daN/m)	Carico concentrato in mezzzeria (daN)
500	1520,53	380,13
750	675,79	253,42
1000	344,91	190,07
1250	176,59	137,96
1500	102,19	95,18
1750	64,36	70,39
2000	43,11	53,89

Profili in acciaio zincato

Materiale: Acciaio zincato Sendzimir UNI EN 10346-2009

Peso specifico	78,5	KN/m ³
Modulo di elasticità longitudinale	210000	N/mm ²
Modulo di elasticità tangenziale	79000	N/mm ²
Coeff. dilatazione termica lineare	1,2*10 ⁻⁵	1/°C
Resistenza al limite ultimo fy	-	N/mm ²
Resistenza al limite di snervamento fy	430	N/mm ²
Resistenza al limite elastico f _{0,2}	190	N/mm ²

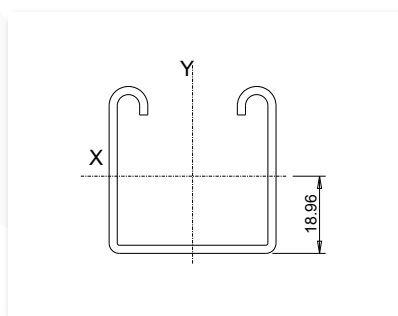
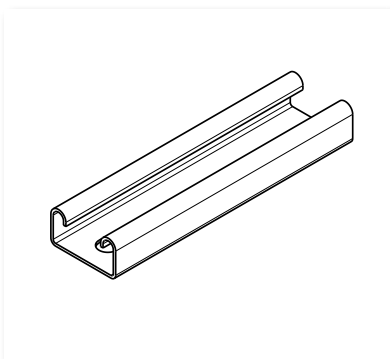

PROFILO 41x21x1,5 mm - Asolato sul fondo

Caratteristiche meccaniche

Area della sezione	A	130,80	mm ²
Peso al metro lineare	pp	1,03	daN/m
Momento d'inerzia X	Jx	7584,98	mm ⁴
Momento d'inerzia Y	Jy	35130,76	mm ⁴
Momento resistente X	Wx	657,32	mm ³
Momento resistente Y	Wy	1713,70	mm ³
Raggio d'inerzia X	ix	7,62	mm
Raggio d'inerzia Y	iy	16,39	mm



Tabella dei carichi ammissibili (con Fmax < L/250)

Lunghezza trave L (mm)	Carico unif. Distrib. (daN/m)	Carico concentrato in mezzeria (daN)
500	391,46	99,91
750	115,99	54,37
1000	48,93	30,58
1250	25,05	19,57
1500	14,50	13,59
1750	9,13	9,99
2000	6,12	7,65

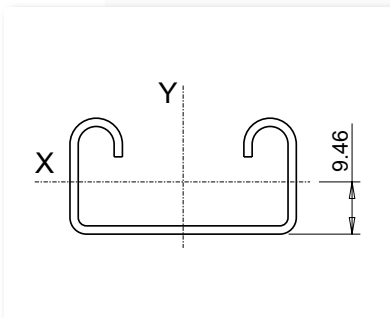
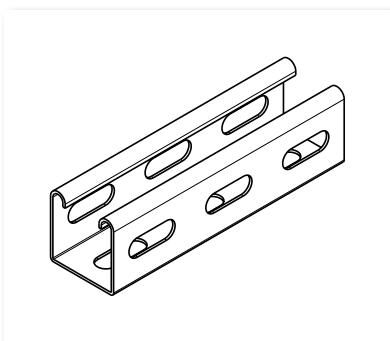

PROFILO 41x41x1,5 mm - Asolato sui tre lati

Caratteristiche meccaniche

Area della sezione	A	159,09	mm ²
Peso al metro lineare	pp	1,25	daN/m
Momento d'inerzia X	Jx	41221,01	mm ⁴
Momento d'inerzia Y	Jy	46199,61	mm ⁴
Momento resistente X	Wx	1899,66	mm ³
Momento resistente Y	Wy	2253,64	mm ³
Raggio d'inerzia X	ix	16,10	mm
Raggio d'inerzia Y	iy	17,04	mm



Tabella dei carichi ammissibili (con Fmax < L/250)

Lunghezza trave L (mm)	Carico unif. Distrib. (daN/m)	Carico concentrato in mezzeria (daN)
500	1155,00	288,75
750	513,33	192,50
1000	265,92	144,37
1250	136,15	106,37
1500	78,79	73,87
1750	49,62	54,27
2000	33,24	41,55

Profili in acciaio inox

Materiale: Acciaio inox AISI 304 n. 14301 EN 10088-3 2005

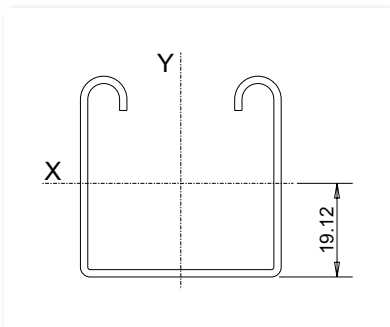
Peso specifico	79,1	KN/m ³
Modulo di elasticità longitudinale	196000	N/mm ²
Modulo di elasticità tangenziale	86000	N/mm ²
Coefficiente dilatazione termica lineare	1,65*10 ⁻⁵	1/°C
Resistenza al limite ultimo fy	500	N/mm ²
Resistenza al limite di snervamento fy	430	N/mm ²
Resistenza al limite elastico f0,2	190	N/mm ²

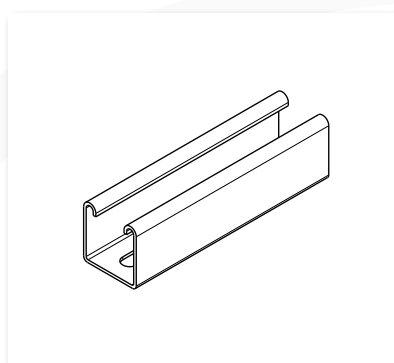

PROFILO 41x41x2 mm - Asolato sul fondo

Caratteristiche meccaniche

Area della sezione	A	250,23	mm ²
Peso al metro lineare	pp	1,98	daN/m
Momento d'inerzia X	Jx	52501,29	mm ⁴
Momento d'inerzia Y	Jy	75547,03	mm ⁴
Momento resistente X	Wx	2414,95	mm ³
Momento resistente Y	Wy	3685,22	mm ³
Raggio d'inerzia X	ix	14,48	mm
Raggio d'inerzia Y	iy	17,38	mm



Tabella dei carichi ammissibili (con Fmax < L/250)

Lunghezza trave L (mm)	Carico unif. Distrib. (daN/m)	Carico concentrato in mezzzeria (daN)
500	1468,29	367,07
750	652,57	244,72
1000	316,12	183,54
1250	161,85	126,45
1500	93,66	87,81
1750	58,98	64,51
2000	39,51	49,39

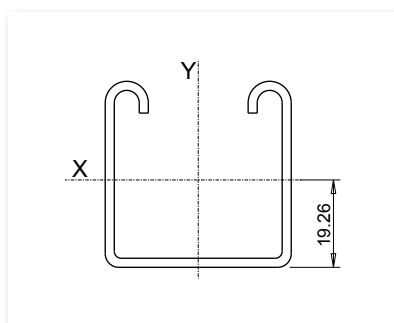
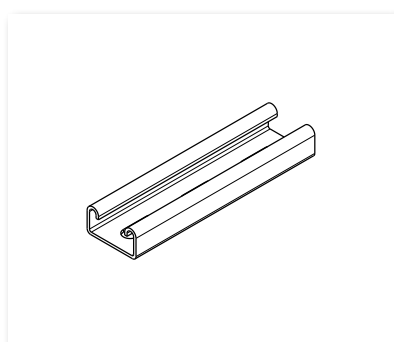

PROFILO 41x21x2 mm - Asolato sul fondo

Caratteristiche meccaniche

Area della sezione	A	170,23	mm ²
Peso al metro lineare	pp	1,35	daN/m
Momento d'inerzia X	Jx	9417,69	mm ⁴
Momento d'inerzia Y	Jy	45100,36	mm ⁴
Momento resistente X	Wx	810,52	mm ³
Momento resistente Y	Wy	2200,02	mm ³
Raggio d'inerzia X	ix	7,44	mm
Raggio d'inerzia Y	iy	16,28	mm



Tabella dei carichi ammissibili (con Fmax < L/250)

Lunghezza trave L (mm)	Carico unif. Distrib. (daN/m)	Carico concentrato in mezzzeria (daN)
500	453,64	123,20
750	134,41	63,01
1000	56,71	35,44
1250	29,03	22,68
1500	16,80	15,75
1750	10,58	11,57
2000	7,09	8,86

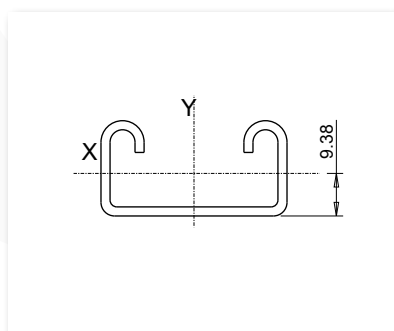

Ω STRUT - Mensole in acciaio

Come già accennato, una delle famiglie di componenti più importanti della gamma Ω Strut è rappresentata dalle mensole di supporto in acciaio.

La gamma si divide in due macro categorie distinte:

- 1) mensole realizzate con profilato 41x41 sp. 2,5mm e zincate a caldo, disponibili nelle versioni con profilo singolo o con profilo doppio.
- 2) mensole realizzate da lamiera stampata nella versione con trattamento superficiale in zincatura elettrolitica e nella versione nervata con trattamento superficiale di zincatura a caldo.

Le mensole in profilo sono fornibili in varie lunghezze standard fino al metro e grazie alla loro resistenza sono particolarmente indicate per sorreggere impiantistica elettrica e idraulica anche con carichi considerevoli.

Raccomandate nelle installazioni dove è richiesta una verifica e certificazione come struttura "sismo-resistente". Oltre al classico utilizzo "a parete", possono essere utilizzate come discese verticali dal soffitto, dando la possibilità di eseguire "tipici" ad albero con più livelli sovrapposti.

La gamma di mensole stampate è invece indicata per il supporto di canaline elettriche porta cavi.

La loro forma e le loro lunghezze ne fanno un prodotto universale utilizzabile con le più svariate tipologie di passerelle disponibili nel mercato, ottimizzando ed uniformando sia lo stock del distributore che il magazzino "picking" dell'impiantista.

Ricordiamo che tutta la gamma di mensole Strut dispone di prove di carico disponibili su richiesta.



NB: Le mensole in profilo, in adeguate quantità, possono essere realizzate su specifica del cliente.

Mensola in profilo 41x41 doppio asolato

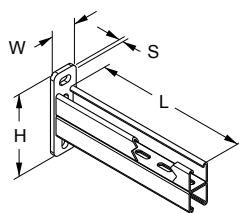

Codice	Riferimento		F	L (mm)	Peso (kg)	Sp. (mm)	Asola profilo (mm)	Dim. piastra	
								HxWxS (mm)	Asola (mm)
MSL1000	MSL-P300-D-Z	6	Z	300	2,14	2,5	30x11	160x50x8	14x25
MSL1005	MSL-P400-D-Z	6	Z	400	2,68	2,5	30x11	160x50x8	14x25
MSL1010	MSL-P500-D-Z	6	Z	500	3,21	2,5	30x11	160x50x8	14x25
MSL1015	MSL-P600-D-Z	1	Z	600	3,76	2,5	30x11	160x50x8	14x25
MSL1020	MSL-P750-D-Z	1	Z	750	4,57	2,5	30x11	160x50x8	14x25
MSL1030	MSL-P900-D-Z	1	Z	900	4,91	2,5	30x11	160x50x8	14x25
MSL1035	MSL-P1000-D-Z	1	Z	1000	5,91	2,5	30x11	160x50x8	14x25

Mensola in profilo 41x41 asolato

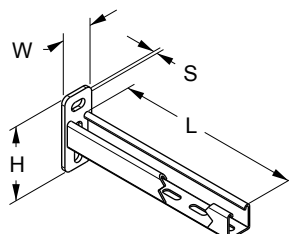

Codice	Riferimento		F	L (mm)	Peso (kg)	Sp. (mm)	Asola profilo (mm)	Dim. piastra	
								HxWxS (mm)	Asola (mm)
MSL1040	MSL-P150-F-Z	10	Z	150	0,69	2,5	30x11	120x50x6	14x25
MSL1045	MSL-P200-F-Z	10	Z	200	0,82	2,5	30x11	120x50x6	14x25
MSL1050	MSL-P300-F-Z	10	Z	300	1,09	2,5	30x11	120x50x6	14x25
MSL1055	MSL-P450-F-Z	6	Z	450	1,73	2,5	30x11	160x50x8	14x25
MSL1060	MSL-P500-F-Z	6	Z	500	1,86	2,5	30x11	160x50x8	14x25
MSL1065	MSL-P600-F-Z	1	Z	600	2,13	2,5	30x11	160x50x8	14x25
MSL1070	MSL-P750-F-Z	1	Z	750	2,53	2,5	30x11	160x50x8	14x25
MSL1071	MSL-P900-F-Z	1	Z	900	2,94	2,5	30x11	160x50x8	14x25
MSL1072	MSL-P1000-F-Z	1	Z	1000	3,21	2,5	30x11	160x50x8	14x25

Mensola stampata - Zincatura elettrolitica

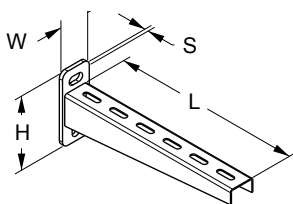

Codice	Riferimento		F	L (mm)	Peso (kg)	Sp. (mm)	Asola profilo (mm)	Dim. piastra	
								HxWxS (mm)	Asola (mm)
MSL1500	MSL-L110-F-E	20	E	110	0,43	1,8	30x9	120x50x6	14x25
MSL1505	MSL-L160-F-E	20	E	160	0,50	1,8	30x9	120x50x6	14x25
MSL1510	MSL-L210-F-E	20	E	210	0,59	1,8	30x9	120x50x6	14x25
MSL1515	MSL-L310-F-E	20	E	310	0,79	1,8	30x9	120x50x6	14x25
MSL1520	MSL-L410-F-E	20	E	410	1,24	1,8	30x9	160x50x6	14x25
MSL1525	MSL-L510-F-E	10	E	510	1,50	1,8	30x9	160x50x8	14x25
MSL1530	MSL-L610-F-E	10	E	610	1,79	1,8	30x9	160x50x8	14x25

Mensola stampata - Zincatura a caldo

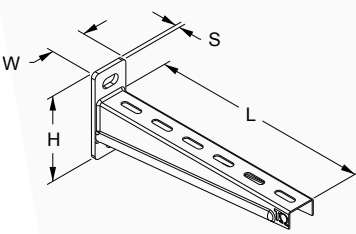

Codice	Riferimento		F	L (mm)	Peso (kg)	Sp. (mm)	Asola profilo (mm)	Dim. piastra	
								HxWxS (mm)	Asola (mm)
MSL2000	MSL-L110-FC-Z	20	Z	110	0,43	1,8	30x9	120x50x6	14x25
MSL2005	MSL-L160-FC-Z	20	Z	160	0,50	1,8	30x9	120x50x6	14x25
MSL2010	MSL-L210-FC-Z	20	Z	210	0,59	1,8	30x9	120x50x6	14x25
MSL2015	MSL-L310-FC-Z	20	Z	310	0,79	1,8	30x9	120x50x6	14x25
MSL2020	MSL-L410-FC-Z	20	Z	410	1,24	1,8	30x9	160x50x6	14x25
MSL2025	MSL-L510-FC-Z	10	Z	510	1,50	1,8	30x9	160x50x8	14x25
MSL2030	MSL-L610-FC-Z	10	Z	610	1,79	1,8	30x9	160x50x8	14x25

Carichi espressi in kg gamma mensole in acciaio



MENSOLA IN PROFILO 41x41 DOPPIO sp.2,5 mm

Codice	Lung. (mm)	Carico max centrale	Carico di punta
MSL1000	300	850	410
MSL1005	400	655	310
MSL1010	500	525	245
MSL1015	600	420	205
MSL1020	750	335	168
MSL1030	900	285	132
MSL1035	1000	245	108

MENSOLA IN PROFILO 41x41 sp.2,5 mm

Codice	Lung. (mm)	Carico max centrale	Carico di punta
MSL1040	150	608	280
MSL1045	200	420	180
MSL1050	300	290	150
MSL1055	450	200	90
MSL1060	500	180	80
MSL1065	600	140	58
MSL1070	750	100	53
MSL1071	900	70	30
MSL1072	1000	52	20

MENSOLA STAMPATA ZINCATURA Elettrolitica

Codice	Lung. (mm)	Carico max centrale	Carico di punta
MSL1500	110	343	219
MSL1505	160	315	157
MSL1510	210	238	120
MSL1515	310	188	117
MSL1520	410	152	71
MSL1525	510	140	67
MSL1530	610	121	80



MENSOLA STAMPATA ZINCATURA A CALDO

Codice	Lung. (mm)	Carico max centrale	Carico di punta
MSL2000	110	343	219
MSL2005	160	315	157
MSL2010	210	238	120
MSL2015	310	188	117
MSL2020	410	152	71
MSL2025	510	140	67
MSL2030	610	121	80



NB: A richiesta sono disponibili i risultati dei test delle prove di carico

Ω STRUT - TABELLE CARICHI MENSOLE

Ω STRUT Spessore 6 mm - Diametro fori 14 mm

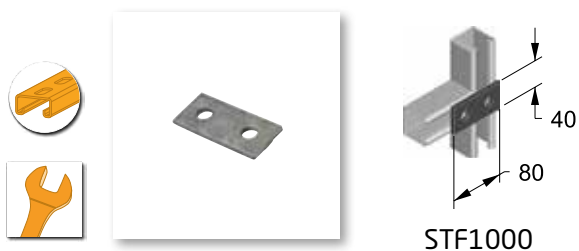

STF1000

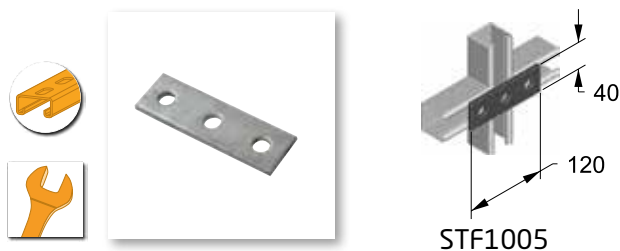

STF1005

STAFFE PIANE - TIPO "P"

Codice	Riferimento	
STF1000	STF-P2	10

Codice	Riferimento	
STF1005	STF-P3	10

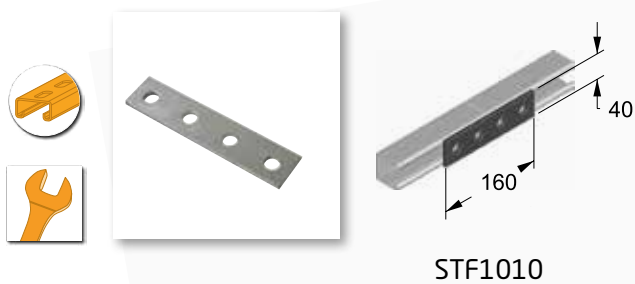

STF1010

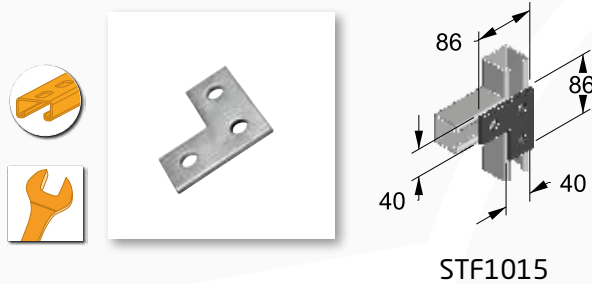

STF1015

Codice	Riferimento	
STF1010	STF-P4	10

Codice	Riferimento	
STF1015	STF-PL3	10

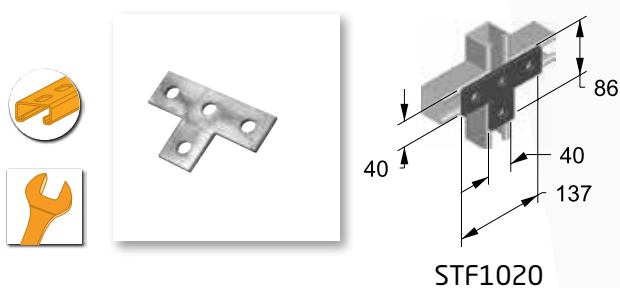

STF1020

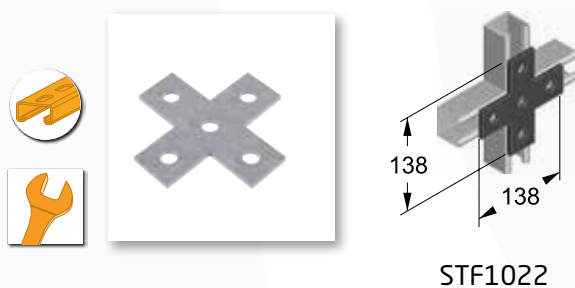

STF1022

Codice	Riferimento	
STF1020	STF-PT4	10

Codice	Riferimento	
STF1022	STF-PC4	10

Spessore 6 mm - Diametro fori 14 mm

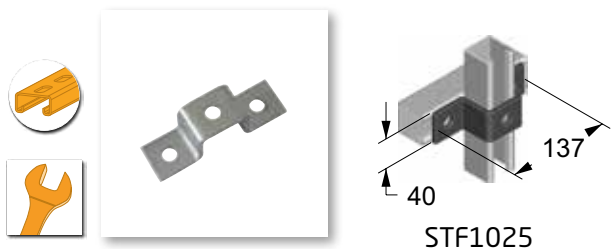

STF1025

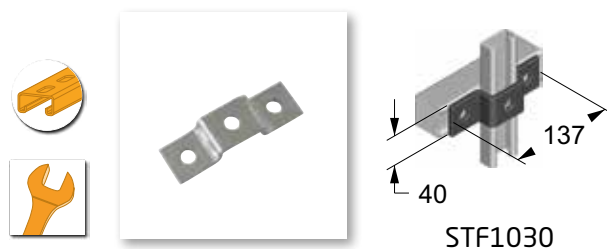

STF1030

STAFFE A OMEGA - TIPO "O"

Codice	Riferimento	
STF1025	STF-041	10

Codice	Riferimento	
STF1030	STF-021	10

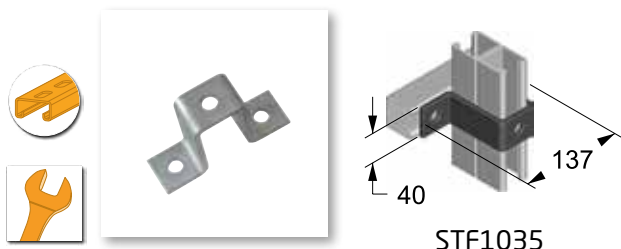

STF1035

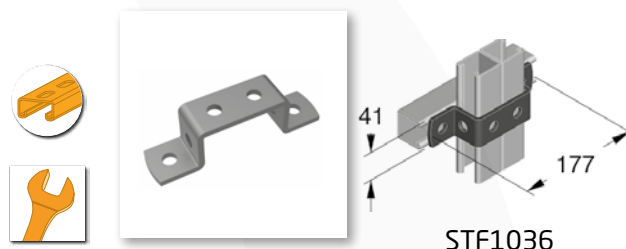

STF1036

Codice	Riferimento	
STF1035	STF-082	10

Codice	Riferimento	
STF1036	STF-082-0	10

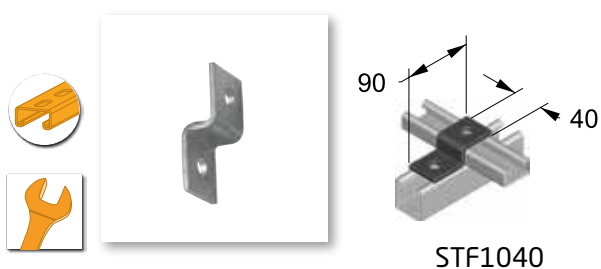

STF1040

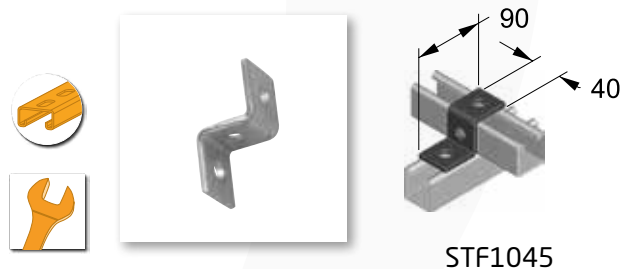

STF1045

STAFFE PER INCROCIO - TIPO "Z"

Codice	Riferimento	
STF1040	STF-Z21	10

Codice	Riferimento	
STF1045	STF-Z41	10

Spessore 6 mm - Diametro fori 14 mm

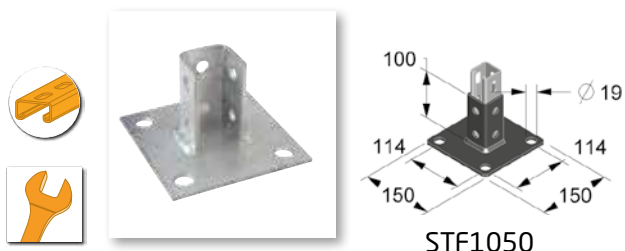

STF1050

PIASTRE BASE - TIPO "B"

Codice	Riferimento	
STF1050	STF-B41	1

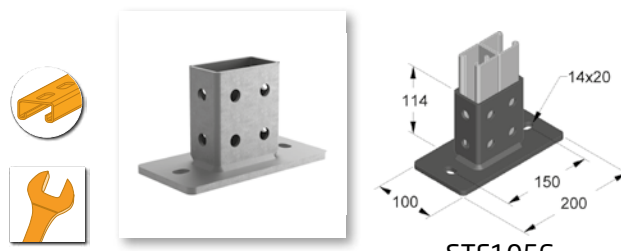

STF1056

Codice	Riferimento	
STF1056	STF-B82	1

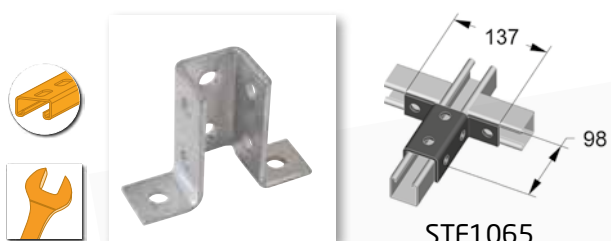

STF1065

STAFFA A CANNONCINO - TIPO "C"

Codice	Riferimento	
STF1065	STF-C41	10

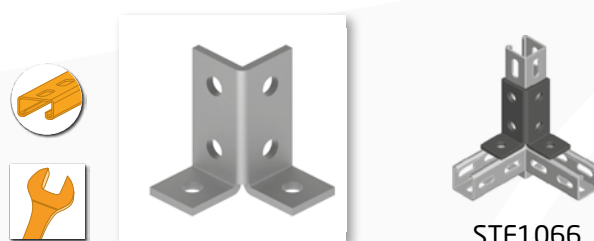

STF1066

Codice	Riferimento	
STF1066	STF-C41-2	10



STF1140

STAFFA DI RINFORZO A SAETTA

Codice	Riferimento	
STF1140	STF-SR300	1

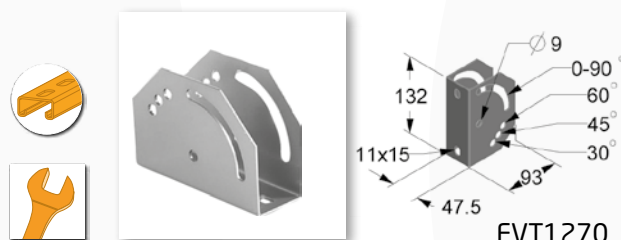

FVT1270

STAFFA AD ANGOLAZIONE VARIABILE

Codice	Riferimento	
FVT1270	FVS-AV-ZC	10

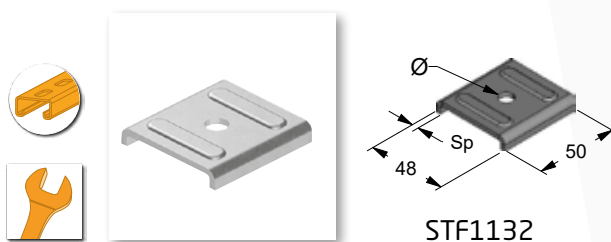

STF1132

PIASTRINA - ZINCATURA ELETTROLITICA

Codice	Riferimento	F	Ø (mm)	Sp. (mm)	
STF1131	STF-PP9-E	E	9	3	50
STF1132	STF-PP11-E	E	11	3	50

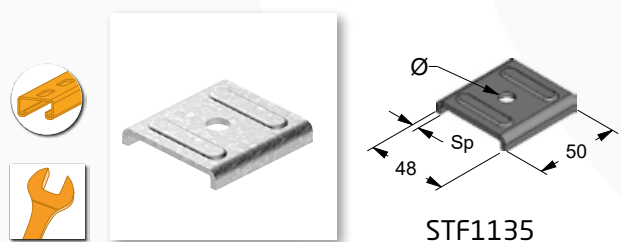

STF1135

PIASTRINA - ZINCATURA A CALDO

Codice	Riferimento	F	Ø (mm)	Sp. (mm)	
STF1135	STF-PP13,5	Z	13,5	3	50

Spessore 6 mm - Diametro fori 14 mm



STF1150

STAFFA AD ANGOLAZIONE VARIABILE PER PROFILO

Codice	Riferimento	
STF1150	STF-AV-PR	8



STF1155

STAFFA AD ANGOLAZIONE VARIABILE PER BARRA FILETTATA

Codice	Riferimento	
STF1155	STF-AV-BF	10



STF1076

GANASCE PER TRAVE METALLICA - TIPO "G"

Codice	Riferimento	
STF1076	STF-G21-G41	10

Utilizzabile per profilo 41x21, 41x21 doppio e profilo 41x41



STF1081

Codice	Riferimento	
STF1081	STF-G82	10

Utilizzabile per profilo 41x41 doppio



STF1095

Codice	Riferimento	
STF1095	STF-GP41	10



STF1096

Codice	Riferimento	
STF1096	STF-GI	10

Ganasce per trave metallica - tipo "G"

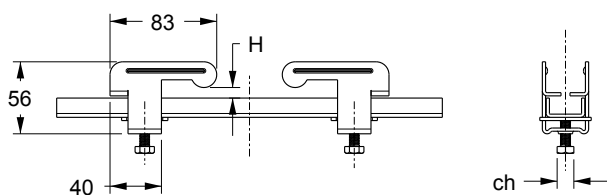
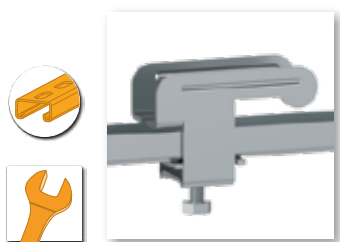

Codice	Riferimento		H max (mm)	ch (mm)
STF2500	STF-GLE-30	20	15	13

Codice ganascia

Profilo per ganascia

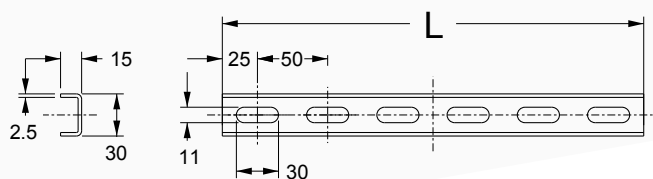
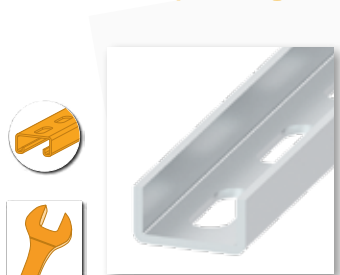

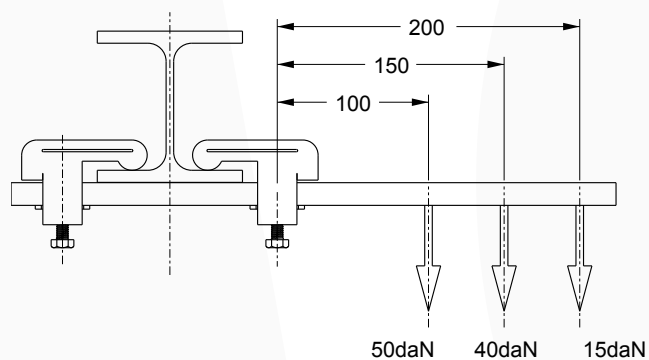

Codice	Riferimento		L (mm)
STF2505	STF-PLE-30	10	300
STF2510	STF-PLE-40	10	400
STF2515	STF-PLE-50	10	500
STF2520	STF-PLE-60	10	600

Codici profili

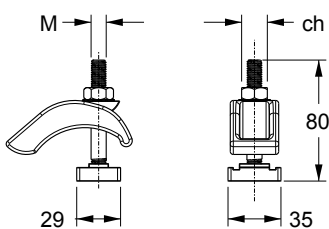

Ganasce per trave metallica - tipo "G"



Codice	Riferimento		H max (mm)	M	ch (mm)	CM (kg)
STF3000	STF-GPE41	10	30	M10	17	360

Staffe da utilizzare con spezzoni di profilo della gamma PRF (vedi da pag. 29 a pag. 36), da ordinare separatamente. Per i valori dei carichi posizionati a sbalzo, contattare il nostro ufficio tecnico.

Staffa completa di piastrina STF1131.

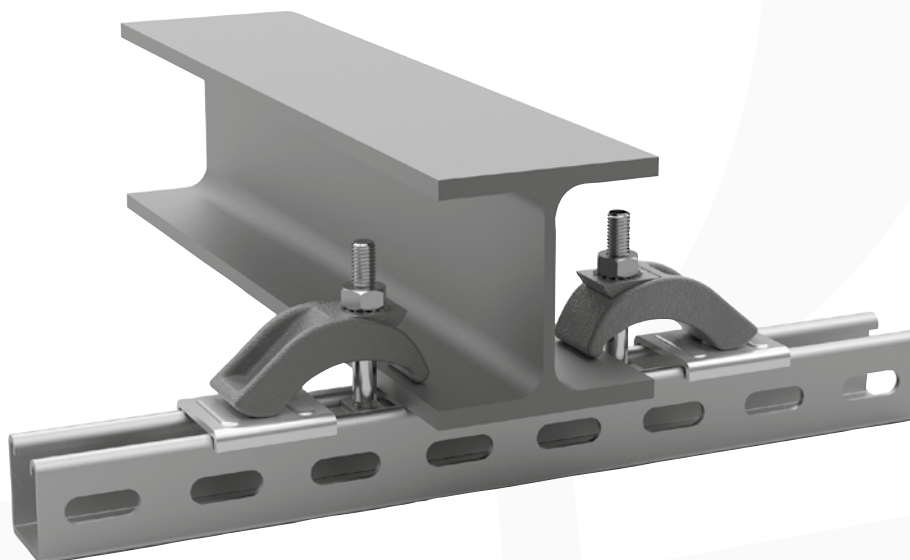
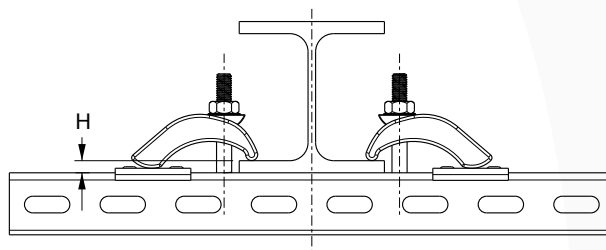

Spessore 6 mm - Diametro fori 14 mm

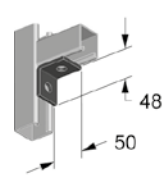
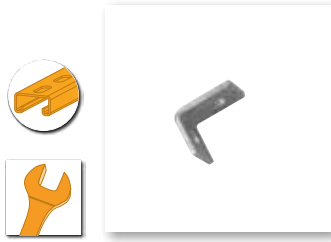

STF1105

Codice	Riferimento	
STF1105	STF-WL2	10

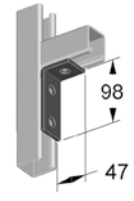
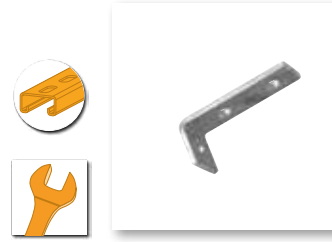

STF1110

Codice	Riferimento	
STF1110	STF-WL3	10

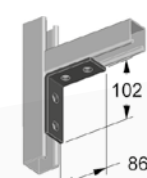
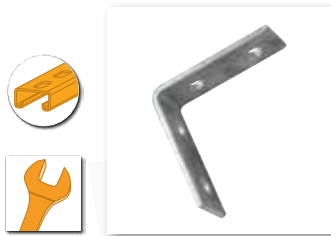

STF1115

Codice	Riferimento	
STF1115	STF-WL4	10

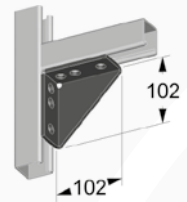
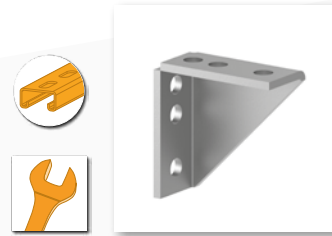

STF1120

Codice	Riferimento	
STF1120	STF-WL4R	10

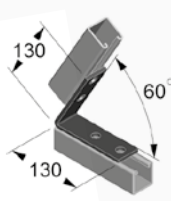

STF1101

Codice	Riferimento	
STF1101	STF-W30A	10

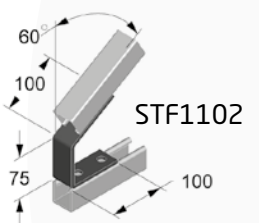
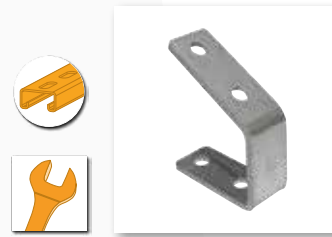

STF1102

Codice	Riferimento	
STF1102	STF-W30-90A	10

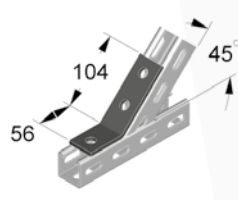
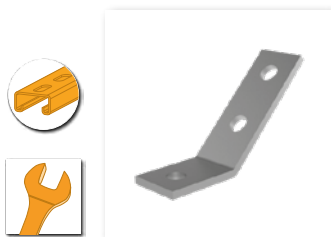

STF1100

Codice	Riferimento	
STF1100	STF-W45	10

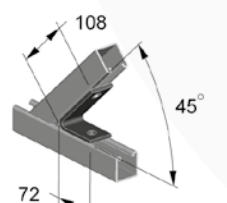
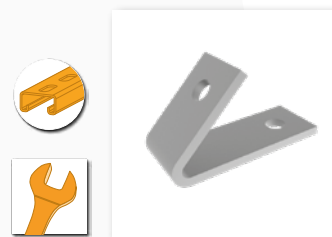

STF1145

Codice	Riferimento	
STF1145	STF-W45A	10

STAFFE ANGOLARI - TIPO "W"



Ω STRUT - Accessori

Per essere davvero completa, una gamma dedicata ai sistemi di fissaggio deve anche comprendere una ricca famiglia di accessori sinergici tra loro.

Partendo dalla vasta serie di dadi dedicati al profilato Ω Strut, zincati ed inox, con molla corta o lunga, proseguiamo poi con una ampia gamma di viteria ed accessori ad essa abbinati.

Di primaria importanza risulta anche la nostra gamma di collari dedicata sia all'idraulica che all'impiantistica elettrica.

Conclude infine l'importante gamma di accessori la famiglia dedicata a morsetti e Ω Clamp sia per struttura metallica che per travi in cemento.



ELETTROZINCATI

Codice	Riferimento		F	M	Sp (mm)
DAP1000	DAP-M6S	100	E	M6	6,5
DAP1005	DAP-M8S	100	E	M8	6,5
DAP1010	DAP-M10S	100	E	M10	8
DAP1015	DAP-M12S	100	E	M12	10
DAP1020	DAP-M6C	100	E	M6	6,5
DAP1025	DAP-M8C	100	E	M8	6,5
DAP1030	DAP-M10C	100	E	M10	8
DAP1035	DAP-M12C	100	E	M12	10
DAP1040	DAP-M6L	100	E	M6	6,5
DAP1045	DAP-M8L	100	E	M8	6,5
DAP1050	DAP-M10L	100	E	M10	8
DAP1055	DAP-M12L	100	E	M12	10

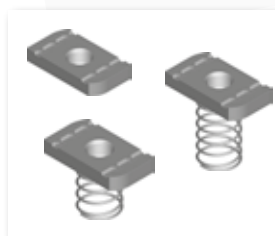
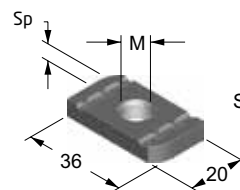

ZINCATI A CALDO

Codice	Riferimento		F	M	Sp (mm)
DAP2000	DAP-M6S-ZC	100	Z	M6	6,5
DAP2005	DAP-M8S-ZC	100	Z	M8	6,5
DAP2010	DAP-M10S-ZC	100	Z	M10	8
DAP2020	DAP-M6C-ZC	100	Z	M6	6,5
DAP2025	DAP-M8-C-ZC	100	Z	M8	6,5
DAP2030	DAP-M10-C-ZC	100	Z	M10	8
DAP2040	DAP-M6-L-ZC	100	Z	M6	6,5
DAP2045	DAP-M8-L-ZC	100	Z	M8	6,5
DAP2050	DAP-M10-L-ZC	100	Z	M10	8

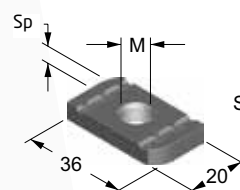

DAP - Dadi per profili STRUT

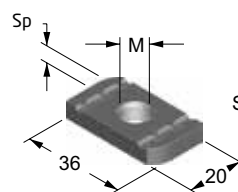

INOX AISI304

Codice	Riferimento		F	M	Sp (mm)
DAP3005	DAP-M8-S-SS	100	SS	M8	6,5
DAP3010	DAP-M10-S-SS	100	SS	M10	8
DAP3025	DAP-M8-C-SS	100	SS	M8	6,5
DAP3030	DAP-M10-C-SS	100	SS	M10	8
DAP3045	DAP-M8L-SS	100	SS	M8	6,5
DAP3050	DAP-M10L-SS	100	SS	M10	8

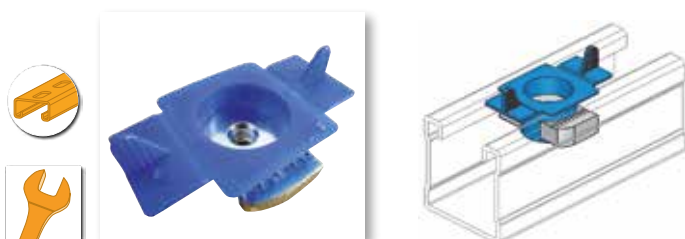

DADI AD ALETTE - ELETTOZINCATI

Codice	Riferimento		F	M	Sp (mm)
DAP1100	DAP-FKA-6	100	E	M6	6,5
DAP1105	DAP-FKA-8	100	E	M8	6,5
DAP1110	DAP-FKA-10	100	E	M10	8
DAP1115	DAP-FKA-12	100	E	M12	10

DAP - Dadi per profili STRUT

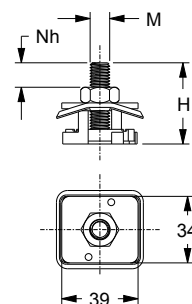
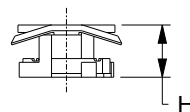

FAST KIT

Codice	Riferimento		F	M	Nh (mm)	CM (kg)
DAP1060	DAP-FK8	100	E	M8		600
DAP1065	DAP-FK10	100	E	M10		950
DAP1070	DAP-FK12	100	E	M12		1000
DAP1075	DAP-FK-M8x40	100	E	M8x40	13	600
DAP1080	DAP-FK-M8x60	100	E	M8x60	33	600
DAP1085	DAP-FK-M10x40	100	E	M10x40	11	950
DAP1090	DAP-FK-M10x60	100	E	M10x60	31	950

Dado e piastrina in acciaio zincato elettrolitico con inserto in plastica pre-assemblato in kit
Utilizzabile sia con profili Strut 41x41 che 41x21 spessore 2,5 - 2 mm

ESEMPIO DI MONTAGGIO



Viti testa martello

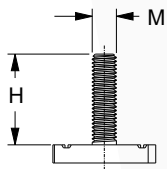

FVT1395

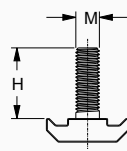

FVT1400

ZINCATURA ELETTROLITICA

Codice	Riferimento	MxH	
FVT1395	FVA-TM-8X30-ZC	M8x30	100
FVT1400	FVA-TM-10X30-ZC	M10x30	100

Viti a testa cilindrica esagono incassato

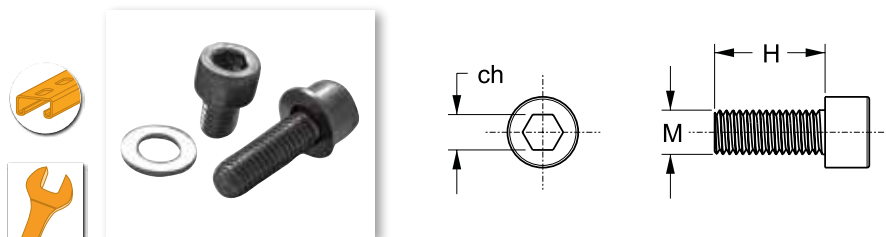

INOX AISI 304

Codice	Riferimento	MxH	ch (mm)	
FVT1330	FVA-TCEI-8x10-INOX	M8x10	6	100
FVT1332	FVA-TCEI-8x20-INOX	M8x20	6	100
FVT1335	FVA-TCEI-8x25-INOX	M8x25	6	100
FVT1337	FVA-TCEI-8x30-INOX	M8x30	6	100
FVT1338	FVA-TCEI-8x35-INOX	M8x35	6	100
FVT1340	FVA-TCEI-8x40-INOX	M8x40	6	100
FVT1341	FVA-TCEI-8x45-INOX	M8x45	6	100
FVT1342	FVA-TCEI-8x50-INOX	M8x50	6	100
FVT1343	FVA-TCEI-8x55-INOX	M8x55	6	100

Codice	Riferimento	MxH	ch (mm)	
FVT1331	FVA-TCEI-8x60-INOX	M8x60	6	100
FVT1333	FVA-TCEI-8x65-INOX	M8x65	6	100
FVT1344	FVA-TCEI-8x70-INOX	M8x70	6	100
FVT1334	FVA-TCEI-8x75-INOX	M8x75	6	100
FVT1345	FVA-TCEI-10x25-INOX	M10x25	8	100
FVT1346	FVA-TCEI-10x20-INOX	M10x20	8	100
FVT1347	FVA-TCEI-10x30-INOX	M10x30	8	100
FVT1350	FVA-TCEI-10x40-INOX	M10x40	8	100
FVT1355	FVA-TCEI-10x50-INOX	M10x50	8	100

Kit Vite TE con dado e rondella

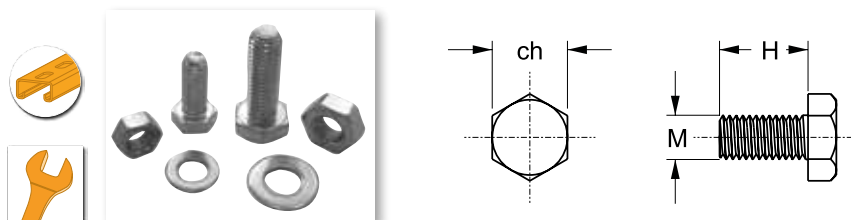

INOX AISI 304

Codice	Riferimento	MxH	ch (mm)	
FVT1320	FVA-TE-8x16-INOX	M8x16	13	100
FVT1325	FVA-TE-10x20-INOX	M10x20	17	100

Kit dado e rondella

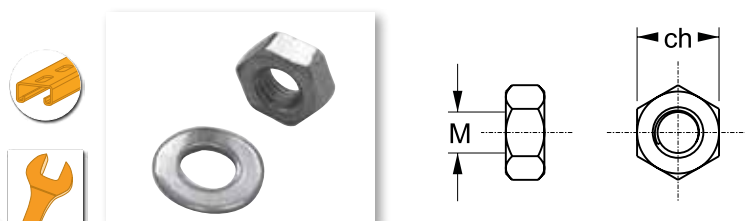

INOX AISI 304

Codice	Riferimento	M	ch (mm)	
FVT1358	FVA-DR-M8-INOX	M8	13	100
FVT1359	FVA-DR-M10-INOX	M10	17	100

Accessori

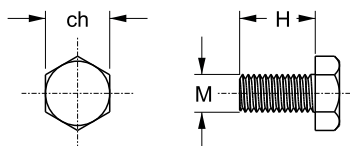
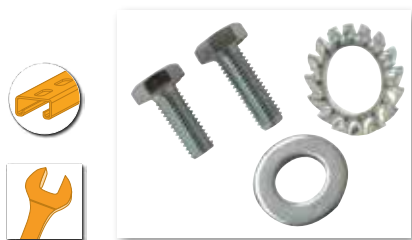

BUL-VITI E RONDELLE PER ELEMENTI STRUT- ZINCATURA ELETTROLITICA

Codice	Riferimento		F	ch (mm)	Ø est. (mm)	MxH
BUL1000	BUL-VTE-M10-25	100	E	17	-	M10x25
BUL1005	BUL-VTE-M10-30	100	E	17	-	M10x30
BUL1006	BUL-VTE-M10-20	100	E	17	-	M10x20
BUL1008	BUL-DADO-M10	100	E	17	-	-
BUL1010	BUL-R-10,5	500	E	-	20	-
BUL1012	BUL-R-30	500	E	-	30	-
BUL1015	BUL-RG-10,5	500	E	-	-	-

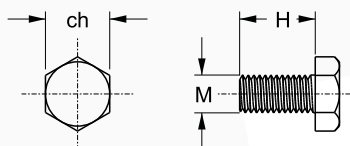
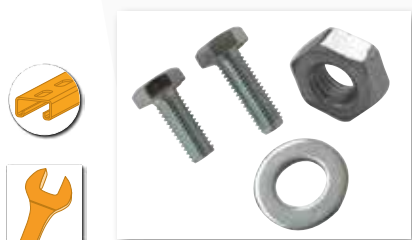

BUL-VITI E RONDELLE PER ELEMENTI STRUT - ZINCATURA A CALDO

Codice	Riferimento		F	ch (mm)	Ø est. (mm)	MxH
BUL1050	BUL-VTE-M10-20-Z	100	Z	17	-	M10x20
BUL1052	BUL-VTE-M10-25-Z	100	Z	17	-	M10x25
BUL1055	BUL-VTE-M10-30-Z	100	Z	17	-	M10x30
BUL1060	BUL-DADO-M10-Z	100	Z	17	-	-
BUL1065	BUL-R-10,5-Z	500	Z	-	20	-
BUL1070	BUL-R-30-Z	500	Z	-	30	-



TAPPI PER PROFILI

Codice	Riferimento	
BUL1020	BUL-TP21	100
BUL1025	BUL-TP41	100

Accessori

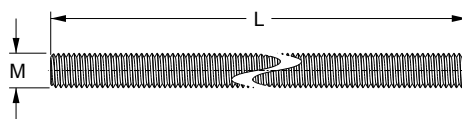
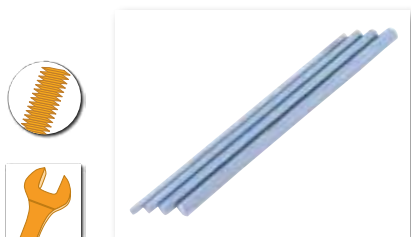

BFA - BARRE FILETTATE

Codice	Riferimento		F	M	L (mm)
ELETTROZINCATE					
BFA1000	BFA1-M6	10	E	M6	1000
BFA1005	BFA3-M6	10	E	M6	3000
BFA1010	BFA1-M8	10	E	M8	1000
BFA1015	BFA3-M8	10	E	M8	3000
BFA1020	BFA1-M10	10	E	M10	1000
BFA1025	BFA3-M10	10	E	M10	3000
BFA1030	BFA1-M12	10	E	M12	1000
BFA1035	BFA3-M12	10	E	M12	3000
INOX					
FVT1405	FVA-BF-M8-inox	10	SS	M8	1000
FVT1410	FVA-BF-M10-inox	10	SS	M10	1000

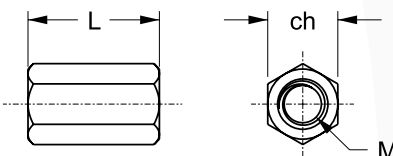

MANICOTTI

Codice	Riferimento		F	M	ch (mm)	L (mm)
ELETTROZINCATI						
BFA1040	GBF-M6-30	100	E	M6	10	30
BFA1045	GBF-M8-30	100	E	M8	13	30
BFA1050	GBF-M10-30	100	E	M10	17	30
INOX						
FVT1415	FVA-MF-8x30-inox	100	SS	M8	13	30
FVT1420	FVA-MF-10x30-inox	100	SS	M10	17	30

Accessori

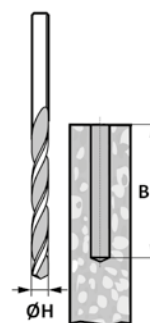
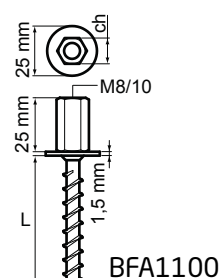
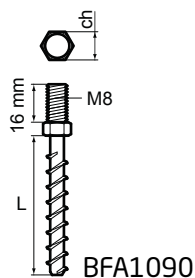

VITI AUTO-FILETTANTI PER CALCESTRUZZO

Codice	Riferimento		F	L (mm)	ØH (mm)	B min (mm)	ch (mm)	M	CM (kg)
BFA1090	FBF-VAC-M	50	A	55	6	60	10	M8	430
BFA1100	FBF-VAC-F	50	A	35	6	40	13	M8/M10	60

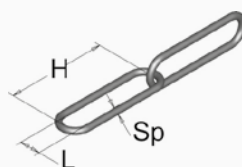

CTN - CATENELLA

Codice	Riferimento		F	H x L (mm)	Sp. (mm)	CL (kg)
CTN1000	CTN-L-Box	50 m	E	13x4	1,6	40
CTN1005	CTN-M-Box	30 m	E	24x5	2,4	80
CTN1010	CTN-P-Box	20 m	E	26x6	3,0	110
CTN1015	CTN-M-Max	100 m	E	24x5	2,4	80
CTN1020	CTN-P-Max	100 m	E	26x6	3,0	110
CTN1025*	CTN-GS	50	E			
CTN1030**	CTN-OM8	50	E	M8 x20		

* CTN1025 gancio a "S" spessore 3 mm; **CTN1030 occhiello M8 - spessore 7 mm - Ø 12 mm

N.B. prodotto non idoneo al sollevamento e alla trazione

Accessori

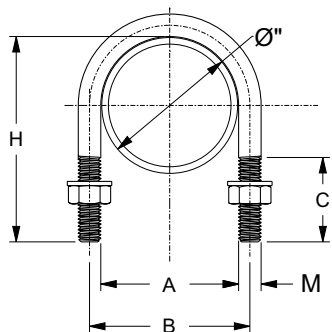
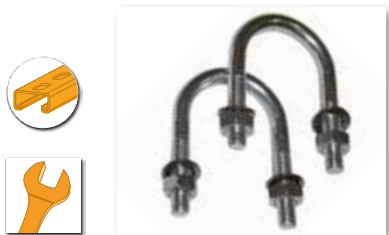

UBT - U-BOLT CAVALLOTTO FISSA TUBO

Codice	Riferimento		F	Ø"	M	A	B	C	H
UBT1000	UBT-1/2"- 6	50	E	1/2	M6	22	28	25	43
UBT1005	UBT-3/4"- 6	50	E	3/4	M6	27	33	25	47
UBT1010	UBT-1"- 6	50	E	1	M6	34	40	25	55
UBT1015	UBT-1"1/4"- 8	50	E	1-1/4	M8	43	51	30	72
UBT1020	UBT-1"1/2"- 8	50	E	1-1/2	M8	49	57	30	73
UBT1025	UBT-2"- 8	50	E	2	M8	61	69	30	85
UBT1030	UBT-2" 1/2 - 8	50	E	2-1/2	M8	77	85	30	101
UBT1035	UBT- 3"- 8	25	E	3	M8	89	97	30	113
UBT1040	UBT- 4"- 8	25	E	4	M8	115	123	35	142



CPR - COLLARI PER PROFILO

Codice	Riferimento		F	Ø"	Ø (mm)
CPR2000	CPR-I-050	50	E	1/2"	20
CPR2005	CPR-I-075	50	E	3/4"	25
CPR2010	CPR-I-100	50	E	1"	32
CPR2015	CPR-I-125	50	E	1-1/4"	40
CPR2020	CPR-I-150	50	E	1-1/2"	50
CPR2025	CPR-I-200	50	E	2"	63
CPR2030	CPR-I-250	50	E	2-1/2"	-
CPR2035	CPR-I-300	25	E	3"	-
CPR2040	CPR-I-400	25	E	4"	-

Accessori

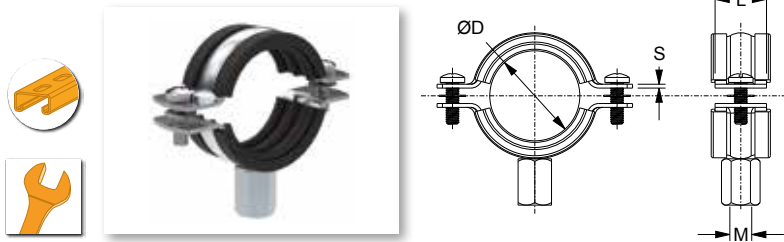

CARATTERISTICHE TECNICHE

- Acciaio zincato elettrolitico
- Isolamento in gomma EPDM (serie "G")
- Riduzione vibrazioni secondo norme DIN 4109: 18db (serie "G")
- Viti di serraggio imperdibili grazie a speciali rondelle in plastica
- Temperatura di utilizzo: -40/ +110 (serie "G")
- Idonei per installazioni sia verticali che orizzontali
- Attacco filettato M8/M10/M12
- Carico di rottura a trazione: 6000N

PCL - Ω PIPE "G" - COLLARI ISOLATI EPDM

Codice	Riferimento		F	Ø"	Ø (mm)	M	L x S (mm)
PCL1000	PCL-G-3/8	100	E	3/8"	16 - 20	M8 / M10	20 x 1,5
PCL1005	PCL-G-1/2	100	E	1/2"	20 - 24	M8 / M10	20 x 1,5
PCL1010	PCL-G-3/4	100	E	3/4"	25 - 28	M8 / M10	20 x 1,5
PCL1015	PCL-G-1	100	E	1"	32 - 35	M8 / M10	20 x 1,5
PCL1020	PCL-G-1-1/4	50	E	1-1/4"	39 - 46	M8 / M10	20 x 1,5
PCL1025	PCL-G-1-1/2	50	E	1-1/2"	48 - 53	M8 / M10	20 x 1,5
PCL1030	PCL-G-2	25	E	2"	59 - 66	M8 / M10	20 x 1,5
PCL1035	PCL-G-2-1/2	25	E	2-1/2"	74 - 80	M8 / M10	25 x 2
PCL1040	PCL-G-3	25	E	3"	87 - 94	M10 / M12	25 x 2
PCL1045	PCL-G-4	12	E	4"	108 - 116	M10 / M12	30 x 3
PCL1050	PCL-G-5	6	E	5"	135 - 143	M10 / M12	40 x 4

Morsetti

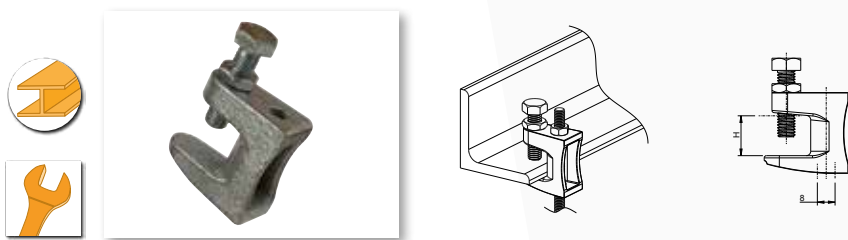

TKM - MORSETTI IN GHISA PER FISSAGGIO A TRAVE

Codice	Riferimento		F	H (mm)	M / Ø	CM (kg)
TKM1000	TKM- M6	50	G	18	M6	120
TKM1005	TKM 8	50	G	18	Ø 9	120
TKM1010	TKM-M8	50	G	18	M8	120
TKM1015	TKM10	50	G	20	Ø 11	250
TKM1020	TKM-M10	50	G	20	M10	250
TKM1025	TKM12	50	G	26	Ø 13	350
TKM1030	TKM-M12	50	G	26	M12	350
TKM1035	TKM-M16	50	G	28	M16	550

Morsetti e collari

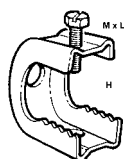

MRT1000

MRT - MORSETTI IN ACCIAIO PER FISSAGGIO A TRAVE

Codice	Riferimento		F	H (mm)	M x L	CM (kg)
MRT1000	MRT-S24	20	D	≤20	M8x35	110
MRT1005	MRT-S32	20	D	≤30	M8x35	120
MRT1010	MRT-S45	10	D	≤45	M8x35	130



MRT - COLLARI AD INCASTRO PER MORSETTI

Codice	Riferimento		F	D (mm)	L x S (mm)	M
MRT1105	MRT-C21	20	D	16-20	16x1,5	M5
MRT1110	MRT-C27	20	D	20,4-25	16x1,5	M5
MRT1115	MRT-C33	20	D	26,9-32	16x1,5	M5
MRT1120	MRT-C39	20	D	33,7-38	20x1,5	M6
MRT1122	MRT-C40	20	D	40-44,5	20x1,5	M6
MRT1125	MRT-C50	20	D	47-51	20x1,5	M6
MRT1130	MRT-C64	20	D	59,2-63,5	20x1,5	M6

Ω CLAMP Staffa universale per profilato Strut

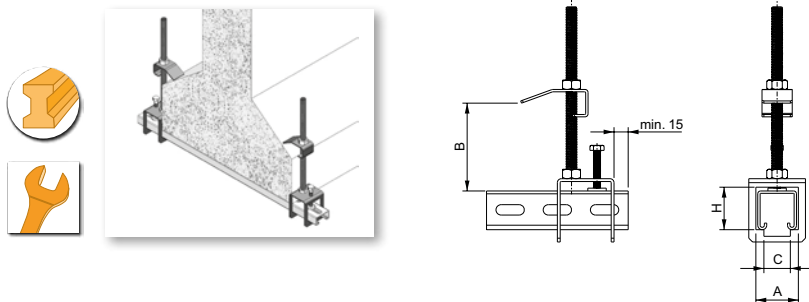

Codice	Riferimento		F	B min-max (mm)	A x H/C (mm)	M	CL (kg)
FTC2021	FTU-41x21	20	E	30-160	43x23/28	M10	75
FTC2041	FTU-41x41	20	E	30-160	43x43/28	M10	75

Profilo da ordinare separatamente. Ogni staffaggio necessita di 2 staffe ed un profilo
Vedi da pag. 29 a pag. 36

ISTRUZIONI DI MONTAGGIO

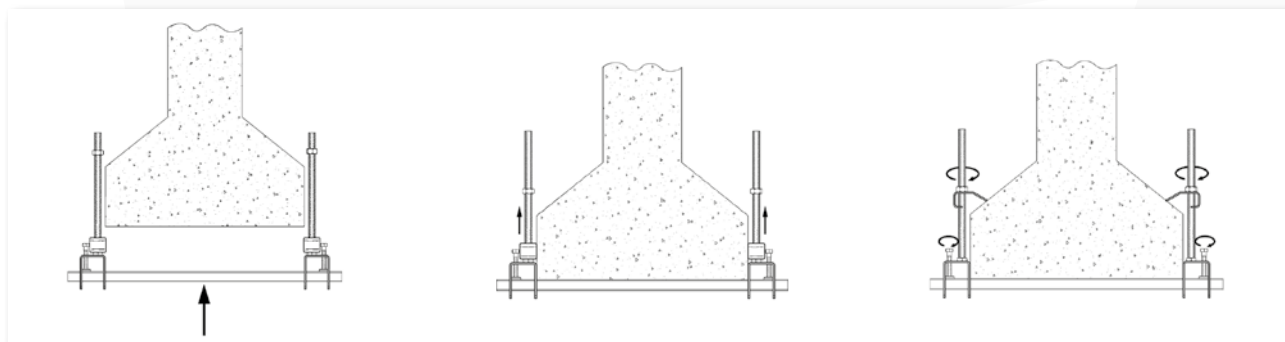

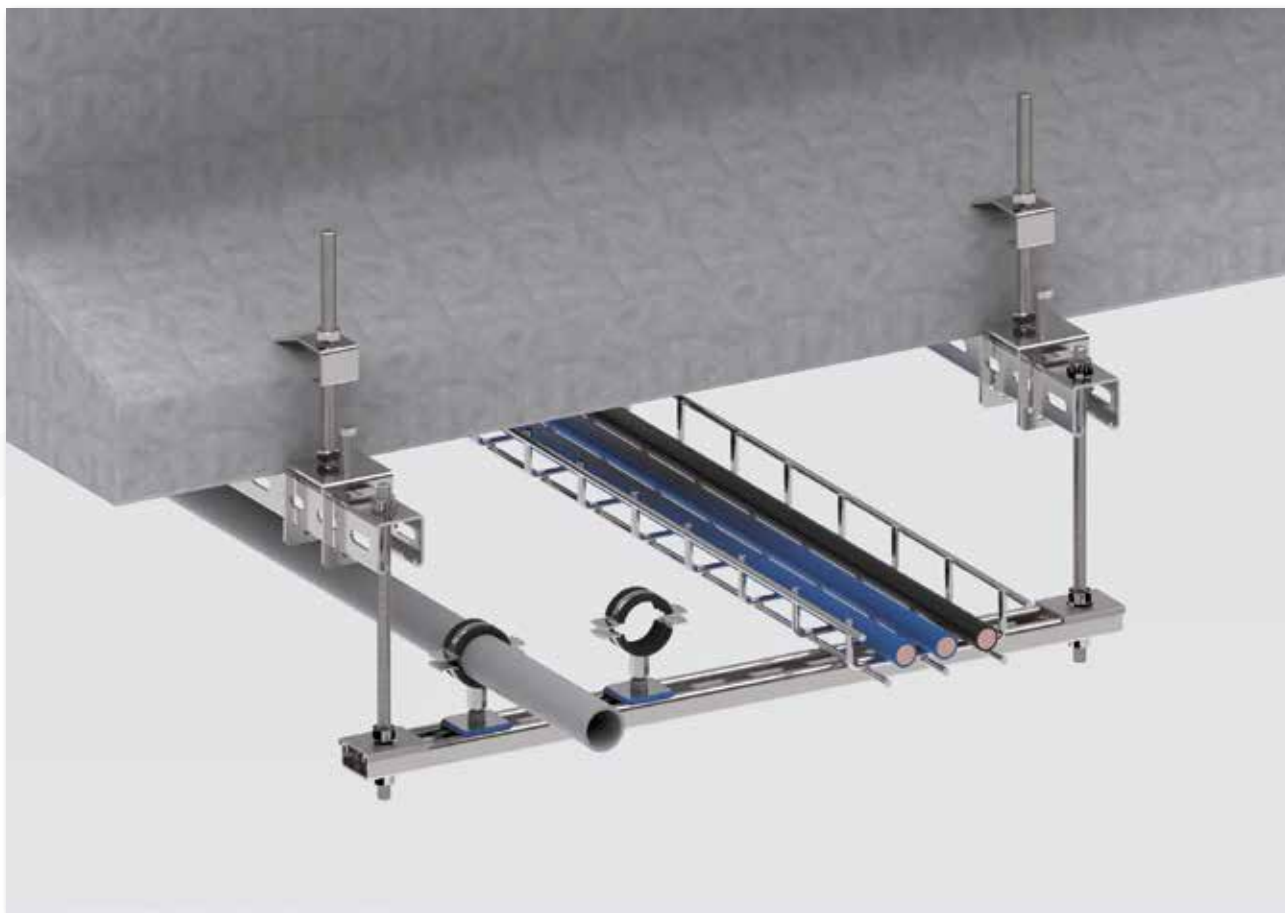



Ω ZIP - Cavetto metallico per sospensione

La nuova generazione di sospensioni a cavetto metallico

Da qualche anno le sospensioni eseguite con catenelle e barre filettate stanno lasciando spazio all'alternativa realizzata con cavetti metallici e sistemi di bloccaggio rapido.

Teknomega da tempo propone al mercato un sistema di sospensioni a cavetto regolabile che vanta una grande affidabilità, oltre che una completezza di gamma all'avanguardia.

Questa gamma permette di utilizzare sia cavo a metraggio di varie sezioni, sia spezzoni di cavo ad alta resistenza pre intestati e tagliati a misura.

Questa duplice soluzione, da accoppiare ai blocchetti di fissaggio rapido della sezione indicata, permette di eseguire sospensioni da 10 a 500 Kg, mantenendo sempre un fattore di sicurezza di 5:1.

Il cavo pre-tagliato a misura Ω ZIP è disponibile con varie tipologie di terminali: chiuso a cappio, con ancorina di fissaggio, con anello dia. 5 mm, con tassello rapido e con terminale provvisto di moschettone.

Completano questa gamma una serie di componenti a "Y" indispensabili per la sospensione di passerelle a griglia e corpi illuminanti.

Visto il grande successo e la diffusione del sistema Ω ZIP siamo lieti di presentare altre due nuove gamme prodotte:

- le sospensioni "a tesata" utili in tutti i casi nei quali non sia possibile fissarsi alla soletta dell'edificio creando una soluzione ideale per la sospensione di corpi illuminanti o altro.
- i rack multilevel eseguiti con cavi portanti e ripiani realizzati con spezzoni di profilati Strut tagliati a misura.

Queste nuove soluzioni si fanno apprezzare per la grandissima affidabilità e per la loro facilità e rapidità d'installazione.

Per tutta la gamma il morsetto di regolazione e bloccaggio è realizzato interamente in zinco ed al suo interno ospita due cunei opportunamente dentellati in acciaio sinterizzato che hanno il compito di far scorrere il cavo in una direzione ma non permetterne lo sfilamento nella direzione opposta.

Operando infine su un comodo pulsante posizionato sul fianco del blocchetto, risulterà semplicissimo regolare la sospensione fino all'altezza desiderata, semplificando enormemente l'operazione della "messa in bolla" dell'intero sistema sospeso. Richiedi maggiori informazioni al nostro Ufficio Tecnico.

CERTIFICAZIONI DISPONIBILI A RICHIESTA



Cavo in matassa e morsetti

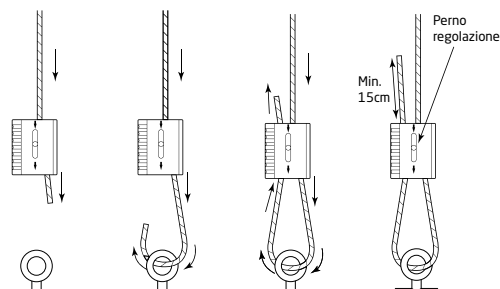

GAMMA GREEN (da 0 a 10 kg) - CAVO Ø 1 (mm)

Codice	Riferimento		L (m)	CL (kg)
ZCT2005	R200GREEN	1	200	10
ZCT2010	R500GREEN	1	500	10

GAMMA GREEN - MORSETTI

Codice	Riferimento		CL (kg)
ZCT3000	KL50	100	10
ZCT3020	KL50PK	10	10

STARTER KIT - GAMMA GREEN

Codice	Riferimento		Cavo (m)	Clip	CL (kg)
ZCT9015	KITGREEN-C&M	1	200	100	10

Nota: Kit composto da 200m di cavo Green e 100 clip

GAMMA SILVER (da 0 a 50 kg) - CAVO Ø 2 (mm)

Codice	Riferimento		L (m)	CL (kg)
ZCT2015	R100SILVER	1	100	50
ZCT2020	R200SILVER	1	200	50

GAMMA SILVER - MORSETTI

Codice	Riferimento		CL (kg)
ZCT3005	KL100	100	50
ZCT3025	KL100PK	10	50

STARTER KIT - GAMMA SILVER

Codice	Riferimento		Cavo (m)	L (m)	CL (kg)
ZCT9016	KITSILVER-C&M	1	200	100	50

Nota: Kit composto da 200m di cavo Silver e 100 clip

GAMMA YELLOW (da 0 a 120 kg) - CAVO Ø 3 (mm)

Codice	Riferimento		L (m)	CL (kg)
ZCT2040	R100YELLOW	1	100	120

GAMMA YELLOW - MORSETTI

Codice	Riferimento		CL (kg)
ZCT3010	KL150	100	120
ZCT3030	KL150PK	10	120
ZCT3050	KL150LOK	10	120

GAMMA PURPLE (da 0 a 230 kg) - CAVO Ø 4 (mm)

Codice	Riferimento		L (m)	CL (kg)
ZCT2050	R100PURPLE	1	100	230

GAMMA PURPLE - MORSETTI

Codice	Riferimento		CL (kg)
ZCT3015	KL200	100	230
ZCT3035	KL200PK	10	230
ZCT3055	KL200LOK	10	230

GAMMA NECTARINE (da 0 a 500 kg) - CAVO Ø 6,35 (mm)

Codice	Riferimento		L (m)	CL (kg)
ZCT2052	R100NECT	1	100	500

GAMMA NECTARINE - MORSETTI

Codice	Riferimento		CL (kg)
ZCT3018	KL600	10	500
ZCT3060	KL600LOK	10	500

Ω ZIP Cavi con terminale a cappio e morsetti



GAMMA GREEN (da 0 a 10 kg)

Codice	Riferimento		L (m)	CL (kg)
ZCT2055	PLE1GREEN	10	1	10
ZCT2057	PLE2GREEN	10	2	10
ZCT2060	PLE3GREEN	10	3	10
ZCT2062	PLE4GREEN	10	4	10
ZCT2065	PLE5GREEN	10	5	10

GAMMA SILVER (da 0 a 45 kg)

Codice	Riferimento		L (m)	CL (kg)
ZCT2070	PLE1SILVER	10	1	45
ZCT2072	PLE2SILVER	10	2	45
ZCT2075	PLE3SILVER	10	3	45
ZCT2077	PLE4SILVER	10	4	45
ZCT2080	PLE5SILVER	10	5	45
ZCT2082	PLE10SILVER	10	10	45

GAMMA YELLOW (da 0 a 90 kg)

Codice	Riferimento		L (m)	CL (kg)
ZCT2150	PLE1YELLOW	10	1	90
ZCT2152	PLE2YELLOW	10	2	90
ZCT2155	PLE3YELLOW	10	3	90
ZCT2157	PLE4YELLOW	10	4	90
ZCT2160	PLE5YELLOW	10	5	90

NB: Kit sospensione composto da cavo e morsetto

Per applicazioni particolari, gamma disponibile a richiesta in versione nero opaco.

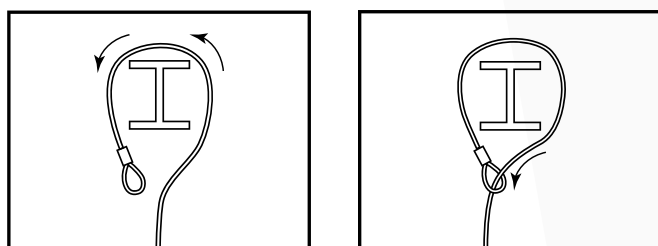

Cavi con terminale ad ancorina e morsetti



GAMMA GREEN (da 0 a 10 kg)

Codice	Riferimento		L (m)	CL (kg)
ZCT2100	PTE1GREEN	10	1	10
ZCT2102	PTE2GREEN	10	2	10
ZCT2105	PTE3GREEN	10	3	10
ZCT2107	PTE4GREEN	10	4	10
ZCT2110	PTE5GREEN	10	5	10

GAMMA SILVER (da 0 a 35 kg)

Codice	Riferimento		L (m)	CL (kg)
ZCT2115	PTE1SILVER	10	1	35
ZCT2117	PTE2SILVER	10	2	35
ZCT2120	PTE3SILVER	10	3	35
ZCT2122	PTE4SILVER	10	4	35
ZCT2125	PTE5SILVER	10	5	35

GAMMA YELLOW (da 0 a 90 kg)

Codice	Riferimento		L (m)	CL (kg)
ZCT2130	PTE1YELLOW	10	1	90
ZCT2132	PTE2YELLOW	10	2	90
ZCT2135	PTE3YELLOW	10	3	90
ZCT2137	PTE4YELLOW	10	4	90
ZCT2140	PTE5YELLOW	10	5	90

(CL= con terminale ad ancorina risultano inferiori a causa della resistenza della stessa)

NB: Kit sospensione composto da cavo e morsetto

Per applicazioni particolari, gamma disponibile a richiesta in versione nero opaco.

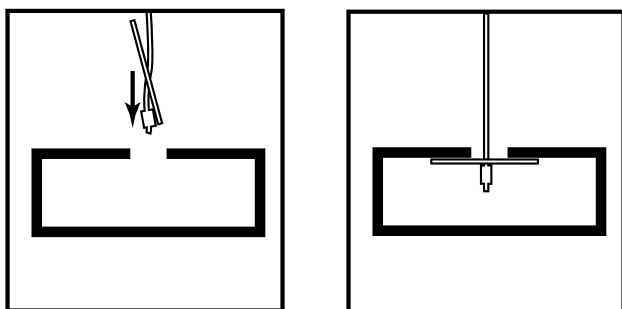

Ω ZIP Cavi con terminale ad anello e morsetti

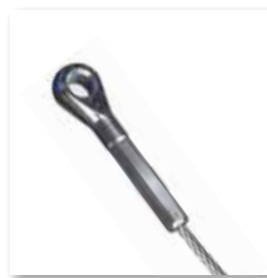

GAMMA GREEN (da 0 a 10 kg)

Codice	Riferimento		L (m)	CL (kg)
ZCT1000	ZLG1	10	1	10
ZCT1005	ZLG2	10	2	10
ZCT1010	ZLG3	10	3	10
ZCT1012	ZLG4	10	4	10
ZCT1015	ZLG5	10	5	10
ZCT1020	ZLG10	10	10	10

GAMMA SILVER (da 0 a 50 kg)

Codice	Riferimento		L (m)	CL (kg)
ZCT1025	ZLS1	10	1	50
ZCT1030	ZLS2	10	2	50
ZCT1035	ZLS3	10	3	50
ZCT1037	ZLS4	10	4	50
ZCT1040	ZLS5	10	5	50
ZCT1045	ZLS10	10	10	50

Ø interno anello: 5mm

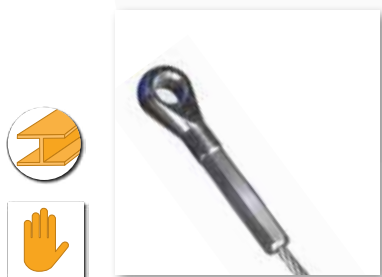

GAMMA YELLOW (da 0 a 120 kg)

Codice	Riferimento		L (m)	CL (kg)
ZCT1050	ZLY1	10	1	120
ZCT1055	ZLY2	10	2	120
ZCT1060	ZLY3	10	3	120
ZCT1062	ZLY4	10	4	120
ZCT1065	ZLY5	10	5	120
ZCT1070	ZLY10	10	10	120

Ø interno anello: 5mm

NB: Kit sospensione composto da cavo e morsetto

Per applicazioni particolari, gamma disponibile a richiesta in versione nero opaco.

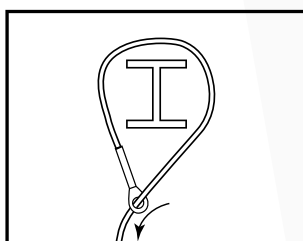
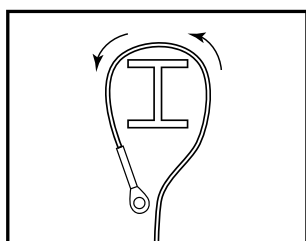

Cavi con terminale a tassello e morsetti



GAMMA GREEN (da 0 a 10 kg)

Codice	Riferimento		L (m)	CL (kg)
ZCT1075	CLG1	10	1	10
ZCT1080	CLG2	10	2	10
ZCT1085	CLG3	10	3	10
ZCT1087	CLG4	10	4	10
ZCT1090	CLG5	10	5	10
ZCT1095	CLG10	10	10	10

GAMMA SILVER (da 0 a 50 kg)

Codice	Riferimento		L (m)	CL (kg)
ZCT1100	CLS1	10	1	50
ZCT1105	CLS2	10	2	50
ZCT1110	CLS3	10	3	50
ZCT1112	CLS4	10	4	50
ZCT1115	CLS5	10	5	50
ZCT1120	CLS10	10	10	50

GAMMA YELLOW (da 0 a 90 kg)

Codice	Riferimento		L (m)	CL (kg)
ZCT1125	CLY1	10	1	90
ZCT1130	CLY2	10	2	90
ZCT1135	CLY3	10	3	90
ZCT1137	CLY4	10	4	90
ZCT1140	CLY5	10	5	90
ZCT1145	CLY10	10	10	90



NB: Kit sospensione composto da cavo e morsetto
Per applicazioni particolari, gamma disponibile a richiesta in versione nero opaco.

ISTRUZIONI DI MONTAGGIO

Utilizzabile su cemento armato-precompresso-calcestruzzo C12/15 e da C20/25 a C50/60

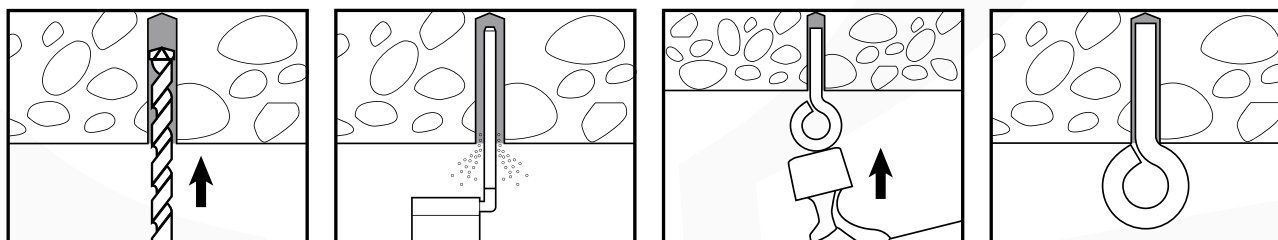

Foro: Ø 6 mm - Profondità min. 30 mm

Cavi per tesate



CAVI DA UTILIZZARE PER LE TESATE

Le tesate si realizzano collegando due punti fissi (pareti laterali o travi) attraverso un cavo metallico assicurato ad entrambe le estremità, tramite gli appositi morsetti e messo in tensione tramite l'apposito attrezzo.

Sul cavo andranno posizionati gli accessori di pagina 77 ai quali andrà fissato il carico da sospendere.

La portata del sistema varia in base al diametro del cavo di supporto utilizzato:

- Yellow : 30kg
- Purple : 75kg
- Nectarine : 100kg

Questi carichi sono da considerarsi con un coefficiente di sicurezza di 5:1 e per installazioni che non prevedono supporti intermedi lungo la tesata.

Prima di realizzare la sospensione, verificare che i punti di ancoraggio siano in grado di sopportare i carichi indotti dalla stessa.

Per le sospensioni dove potrebbero presentarsi ondulazioni o vibrazioni si raccomanda l'utilizzo di morsetti con vite di bloccaggio, vedi pagina 71.

Di seguito lo schema di installazione.

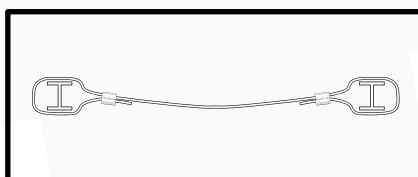
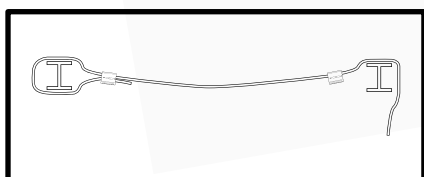

Kit di fissaggio a trave

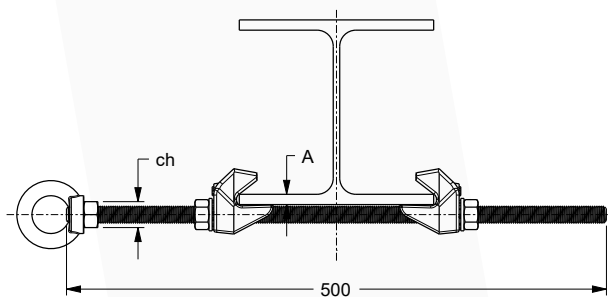

Codice	Riferimento		F	A	ch
ZCT2500	KIT-FSG-TR	1	E	8 ÷ 16	24

Cavi di sospensione per tesate

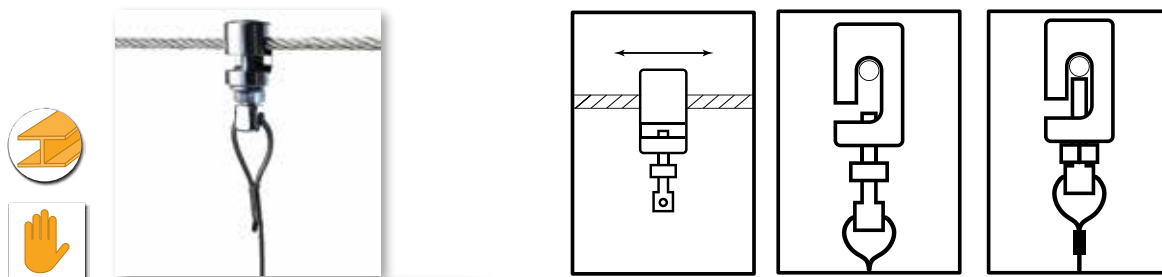

PER UTILIZZO CON CAVI YELLOW E PURPLE

Codice	Riferimento		L (m)	CL (kg)
ZCT2510	GLS-M6-1	10	1	35
ZCT2520	GLS-M6-3	10	3	35
ZCT2530	GLS-M6-5	10	5	35

PER UTILIZZO CON CAVI NECTARINE

Codice	Riferimento		L (m)	CL (kg)
ZCT2550	GLS-M8-1	10	1	35
ZCT2560	GLS-M8-3	10	3	35
ZCT2570	GLS-M8-5	10	5	35



Morsetti per Rack Ω STRUT

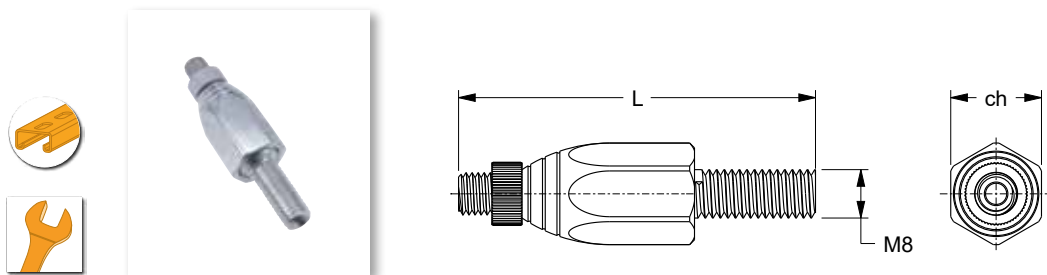

MORSETTI GAMMA SILVER (da 0 a 45 kg)

Codice	Riferimento		Descrizione	L	ch	CL (kg)
ZCT2200	CL-SL-100	10	Morsetto per cavo Silver	59	15	45

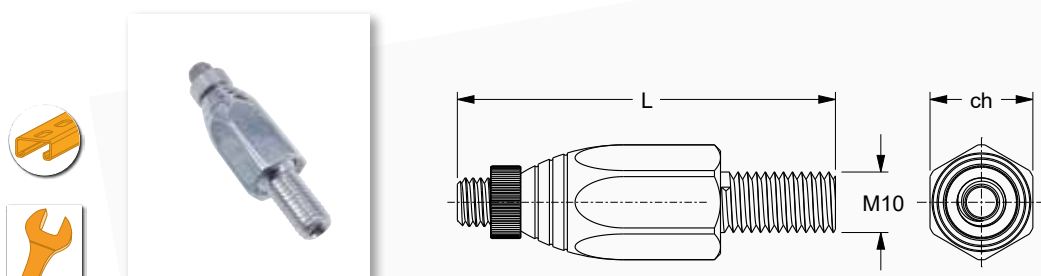

MORSETTI GAMMA YELLOW (da 0 a 90 kg)

Codice	Riferimento		Descrizione	L	ch	CL (kg)
ZCT2210	CL-SL-150	10	Morsetto per cavo Yellow	62,5	17	90

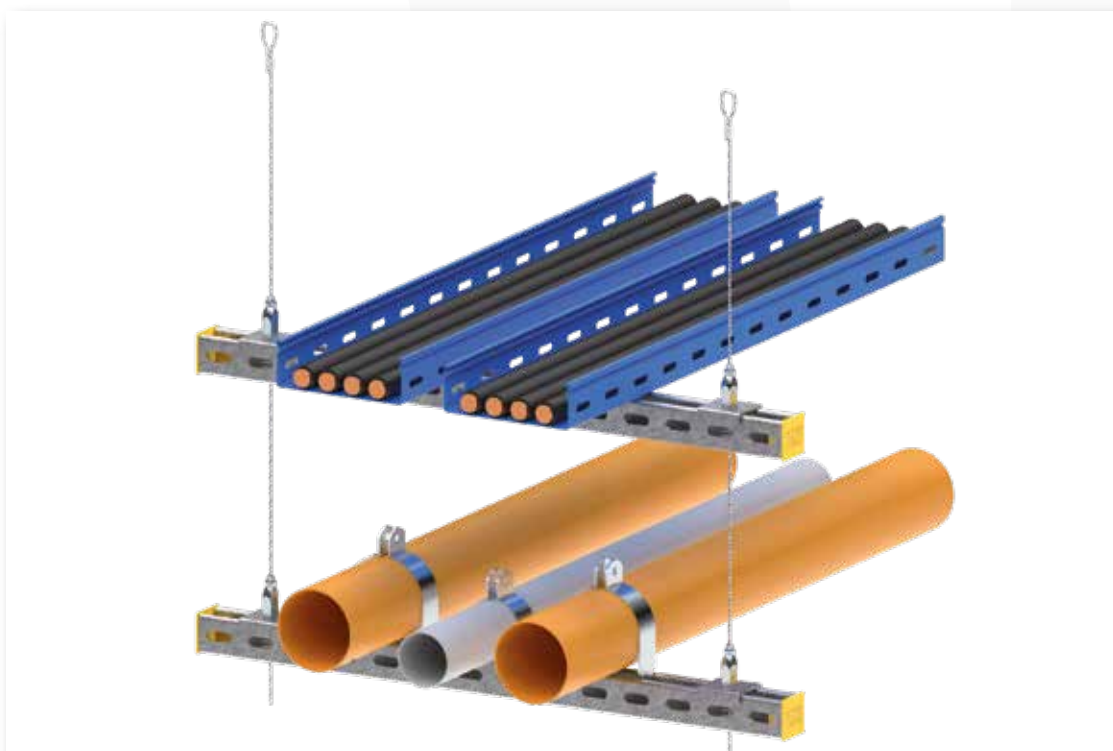

Cavi per Rack Ω STRUT



CAVI TERMINALE A CAPPIO GAMMA SILVER (da 0 a 45 kg)

Codice	Riferimento		L (m)	CL (kg)
ZCT2235	PLE-SL-2S	10	2	45
ZCT2240	PLE-SL-3S	10	3	45
ZCT2250	PLE-SL-5S	10	5	45

CAVI TERMINALE A CAPPIO GAMMA YELLOW (da 0 a 90 kg)

Codice	Riferimento		L (m)	CL (kg)
ZCT2265	PLE-SL-2Y	10	2	90
ZCT2270	PLE-SL-3Y	10	3	90
ZCT2280	PLE-SL-5Y	6	5	90



CAVI TERMINALE A TASSELLO GAMMA SILVER (da 0 a 45 kg)

Codice	Riferimento		L (m)	CL (kg)
ZCT2305	CL-SL-2S	10	2	45
ZCT2310	CL-SL-3S	10	3	45
ZCT2320	CL-SL-5S	10	5	45

CAVI TERMINALE A TASSELLO GAMMA YELLOW (da 0 a 90 kg)

Codice	Riferimento		L (m)	CL (kg)
ZCT2335	CL-SL-2Y	10	2	90
ZCT2340	CL-SL-3Y	10	3	90
ZCT2350	CL-SL-5Y	6	5	90



- Profili gamma PRF vedi pag. 29-36
- Piastrine STF1131/ STF1132 vedi pag. 50
- Dadi STRUT vedi pag. 56

Cavi con terminale a moschettone e morsetti

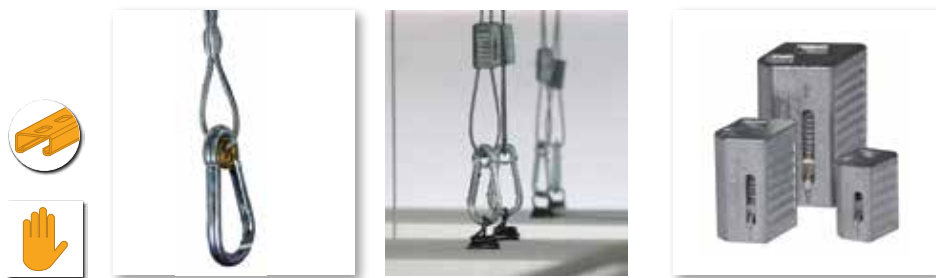

GAMMA GREEN (da 0 a 10 kg)

Codice	Riferimento		L (m)	CL (kg)
ZCT1150	KL1	10	1	10
ZCT1155	KL2	10	2	10
ZCT1160	KL3	10	3	10
ZCT1162	KL4	10	4	10
ZCT1165	KL5	10	5	10
ZCT1170	KL10	10	10	10

GAMMA SILVER (da 0 a 50 kg)

Codice	Riferimento		L (m)	CL (kg)
ZCT1175	KLS1	10	1	50
ZCT1180	KLS2	10	2	50
ZCT1185	KLS3	10	3	50
ZCT1187	KLS4	10	4	50
ZCT1190	KLS5	10	5	50
ZCT1195	KLS10	10	10	50

NB: Kit sospensione composto da cavo e morsetto

Per applicazioni particolari, gamma disponibile a richiesta in versione nero opaco.

Cavi per supporti a "Y"



GAMMA "Y" CON MOSCHETTONE

Codice	Riferimento		L (mm)	CL (kg)
ZCT1205	TRS150-200	10	300	50
ZCT1210	TRS300-400	10	460	50

GAMMA "Y" CON ANCORINA

Codice	Riferimento		L (mm)	CL (kg)
ZCT1220	LUM-150-200	10	300	35
ZCT1225	LUM-300-400	10	460	35

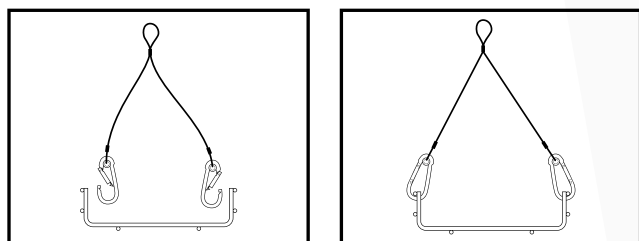

Cavi con staffa a 45° per controventature



GAMMA SILVER (da 0 a 45 kg)

Codice	Riferimento		L (m)	CL (kg)
ZCT4000	SR2S	8	2	45
ZCT4005	SR3S	8	3	45
ZCT4010	SR5S	8	5	45

GAMMA YELLOW (da 0 a 90 kg)

Codice	Riferimento		L (m)	CL (kg)
ZCT4015	SR2Y	8	2	90
ZCT4020	SR3Y	8	3	90
ZCT4025	SR5Y	8	5	90

GAMMA PURPLE (da 0 a 200 kg)

Codice	Riferimento		L (m)	CL (kg)
ZCT4030	SR2P	4	2	200
ZCT4035	SR3P	4	3	200
ZCT4040	SR5P	4	5	200

NB: Kit sospensione composto da cavo e morsetto

Per le staffe da utilizzare con i cavi, vedi nostro catalogo per soluzioni di fissaggio sismo-resistente.

ZIP Clip - Accessori



Codice	Riferimento		Descrizione
ZCT1230	UNI1	10	Adattatore M6x20 mm
ZCT1235	UNI2	10	Adattatore M6x45 mm
ZCT1240	CPA1	50	Angolare isolante
ZCT1245	PVC1	1	Guaina in PVC per gamma Silver e Yellow
ZCT1250	CUT1	1	Pinza tronchese per cavo G, S e Y
ZCT1255	CUT3	1	Pinza tronchese per cavo P e N
ZCT1260	TT1	1	Attrezzo per tensionamento cavi



Strutture per impianti fotovoltaici

Lo sviluppo avuto nel settore delle fonti di energie alternative è strettamente legato alla ricerca di soluzioni che aiutino a diminuire la dipendenza da materie prime come petrolio, gas e carbone.

Per ovviare alle problematiche dettate dalle "vecchie" fonti di sostentamento sono stati avviati programmi ecologici che incentivano soluzioni a basso impatto ambientale; esempio eclatante risulta essere la realizzazione di impianti Fotovoltaici in tutte le più svariate accezioni.

Il cuore dell'impianto è composto da moduli che sfruttano l'energia del sole producendo corrente continua, da inverter che la trasformano in alternata utile per l'immissione nella normale rete elettrica, da contatori che misurano sia l'energia prodotta sia quella immessa nella rete.

È qui che Teknomega entra in azione. Sfruttando le ampie conoscenze nel settore dei "Sistemi di Fissaggio Industriale", abbiamo studiato un nuovo programma dedicato al mondo del fissaggio per impianti Fotovoltaici. Tutte le parti dell'impianto devono essere fissate alla struttura portante; noi abbiamo creato soluzioni nate per durare nel tempo garantendo qualità ed affidabilità di tutti i suoi componenti. La gamma di fissaggio TEKNOMEGA copre le più svariate applicazioni: su tetto piano, su lamiera grecata o su tetto inclinato a falda, fornendo sempre la soluzione più idonea all'utilizzo. Un altro fiore all'occhiello di Teknomega è dato dall'estrema importanza ricoperta dalla ricerca di nuove soluzioni, sempre pensate e sviluppate per risolvere problematiche legate alla rapidità ed universalità di installazione. Lo staff Teknomega è inoltre in grado di affiancarvi in fase di scelta prodotto e, su richiesta, di certificare i tipici più idonei per la Vostra installazione.

In questo catalogo potrete trovare numerose nuove soluzioni per risolvere le vostre problematiche di cantiere, sempre nel rispetto delle normative, seguendo lo stile e l'affidabilità che contraddistingue il marchio Teknomega.

Abbiamo fissato il sole

SOMMARIO

Ω ALU	Profili in alluminio	82
Ω STRUT	Profili in acciaio	84
Fissaggio per pannelli fotovoltaici		
	Ganasce laterali di fissaggio	86
	Ganasce a "Ω" per fissaggio intermedio	87
	Staffe per tetto a falda	90
	Staffe per lamiera grecata	92
	Kit universali per lamiera grecata	93
	Profili ALU per lamiera grecata	95
	Vitoni a doppia filettatura	96
Strutture di fissaggio per tetto piano		
	Triangoli	98
	Triangoli doppi	99
	Zavorre in cemento	100
Staffe in acciaio per profilo Ω STRUT		
	Staffe zincate a caldo	103
	Viteria e minuteria metallica	105
	Accessori	108
Ω BLOCK	Ripartitori	112
	Foto di applicazioni	118
Caratteristiche dei profili		
	Profili in acciaio	122
	Profili in alluminio	124
Elenco Codici Alfanumerico		129

LEGENDA

DIMENSIONI

M = Foro filettato
D = Foro passante Ø... o Diametro utilizzabile
L = Lunghezza in metri

CARICHI

CL kg = Carico statico di lavoro espresso in kg
CM kg = Carico massimo ammissibile espresso in kg
fattore di sicurezza 1 : 1

FINITURA (F)

S = Zincatura Sendzimir
Z = Zincatura a caldo secondo DIN 50976 - CEI 7.6
E = Zincatura elettrolitica secondo UNI 4721
SS = Acciaio Inossidabile AISI304
AL = Alluminio

• ALU ALLUMINIO LEGA 6060 -T6
(EN AW-ALMGS-UNI EN 573/3)

L'adozione di profilati in alluminio garantisce un'ottima resistenza alle sollecitazioni mantenendo grande leggerezza, evitando quindi di sovraccaricare le strutture portanti.

Z → ACCIAIO ZINCATO A CALDO

(Acciaio FeP02 zincato UNI EN 10111-2008)
L'acciaio, dopo una preparazione chimica, viene immerso in un bagno di zinco in fusione (450-460°C). Gli spessori variano dai 60 agli 80 micron. L'eventuale patina bianca, dovuta alla formazione di idrossicarbonato di zinco non influisce minimamente sulle prestazioni di resistenza alla corrosione.

S+V → SENDZIMIR + VERNICIATURA A POLVERE

Utilizzando una base di lamiera zincata Sendzimir (UNI EN 10327-DX51D) si effettua un ulteriore rivestimento con polveri poliesteri termoindurenti. La resistenza alla corrosione del suddetto trattamento si è dimostrata più che ottima (Il materiale a catalogo può essere ordinato a richiesta con colori RAL a scelta).

SS → ACCIAIO INOX AISI 304 e AISI 430

Una qualità ineccepibile degli acciai inossidabili garantiscono ai componenti installati un'imbattibile durata nel tempo; mai come in applicazioni dedicate a staffaggi nel settore fotovoltaico detta affidabilità nel tempo è risultata tanto importante..6

INSTALLARE CON:



Mano



Cacciavite



Martello



Trapano



Chiave

APPLICARE SU:



Trave
cemento



Pendino
metallico



Putrella
metallica



Muro
cemento



Profilo
metallico



Lamiera
grecata



Profilo
controsoffitto



Tetto
a falda



Barra
filettata



Tetto
piano

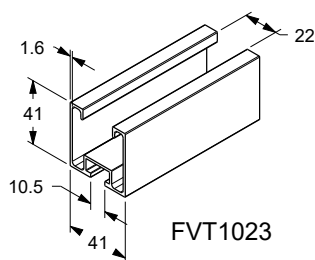

FVT1023

PROFILO SEMPLICE - Sp. 1,6mm

Codice	Riferimento	L (m)	Sp. (mm)	Peso (kg)	
FVT1023	FVP-L3,3-SL-ALU	3,3	1,6	2,52	1
FVT1024	FVP-L4,4-SL-ALU	4,4	1,6	3,57	1
FVT1015	FVP-L6,2-SL-ALU	6,2	1,6	4,75	1

* Utilizzare dadi tipo DAP con molla lunga (vedi pag. 105)

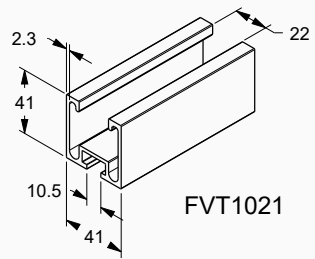

FVT1021

PROFILO SEMPLICE - Sp. 2,3mm

Codice	Riferimento	L (m)	Sp. (mm)	Peso (kg)	
FVT1021	FVP-L3,3-SL-ALU	3,3	2,3	3,72	1
FVT1026	FVP-L4,4-SL-ALU	4,4	2,3	4,96	1
FVT1005	FVP-L6,2-SL-ALU	6,2	2,3	7,00	1

* Utilizzare dadi tipo DAP con molla lunga (vedi pag. 105)

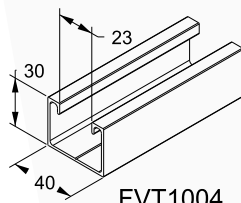

FVT1004

PROFILO RIBASSATO

Codice	Riferimento	L (m)	Sp. (mm)	Peso (kg)	
FVT1004	FVP-L3,1-RI-ALU	3,1	1,6	1,66	1
FVT1009	FVP-L6,2-RI-ALU	6,2	1,6	3,32	1

* Utilizzare dadi tipo DAP con molla lunga (vedi pag. 105)

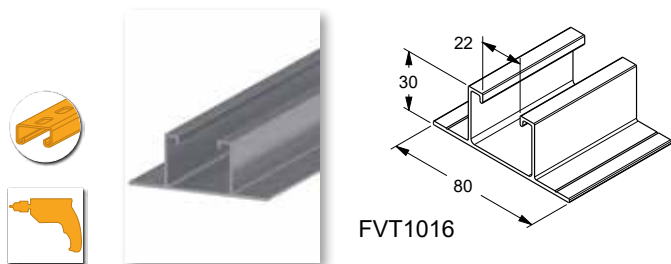

PROFILO A BASE LARGA

Codice	Riferimento	L (m)	Sp. (mm)	Peso (kg)	
FVT1016	FVP-L3,1-UNI-ALU	3,1	2	2,32	1
FVT1017	FVP-L4,2-UNI-ALU	4,2	2	3,14	1
FVT1018	FVP-L6,2-UNI-ALU	6,2	2	4,63	1
FVT1019	FVP-L0,4-UNI-ALU	0,4	2	0,3	1

Con i profili FVT1016, FVT1017 e FVT1018 possono essere utilizzate le ganasce premontate.



ANGOLARE 60x40x4

Codice	Riferimento	L (m)	Sp. (mm)	Peso (kg)	
FVT1011	FVP-L3,1-ANG-ALU	3,1	4	3,22	1
FVT1012	FVP-L6,2-ANG-ALU	6,2	4	6,44	1

Giunti per profili

ESEMPIO DI MONTAGGIO

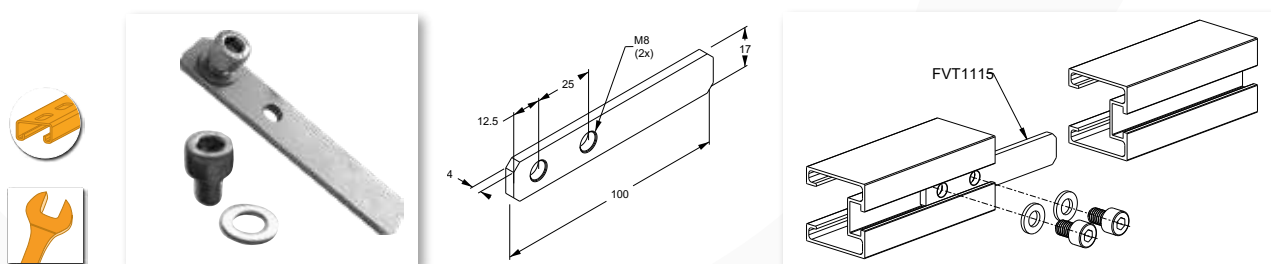

Codice	Riferimento	Da utilizzare per	F	
FVT1115	FVS-PU-INOX	Profili in alluminio gamma FVT	SS	25

FVT1115 è comprensivo di 2 viti di serraggio TCEI M8x10

Profili STRUT in acciaio

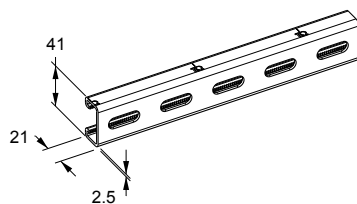

41x21 FORATO SUL FONDO

Codice	Riferimento	L (m)	Sp. (mm)	Peso (kg)	Asola profilo (mm)	Inter. asola (mm)	F	
PRF1145	PRF-B3-ZF	3	2,5	5,1	30x11	50	Z	1
PRF1150	PRF-B4-ZF	4	2,5	6,8	30x11	50	Z	1
PRF1155*	PRF-B6-ZF	6	2,5	10,2	30x11	50	Z	1
PRF9004	PRF-B3-SSF	3	2	4,3	20x11	50	SS	1

Utilizzare dadi tipo DAP con molla corta (vedi pag. 105)

*Su richiesta

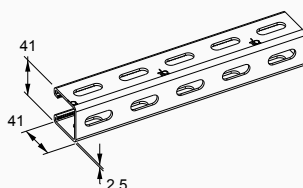

41x41 FORATO SU 3 LATI

Codice	Riferimento	L (m)	Sp. (mm)	Peso (kg)	Asola profilo (mm)	Inter. asola (mm)	F	
PRF1225	PRF-A3-ZF3	3	2,5	7,5	30x11	50	Z	1
PRF1230	PRF-A4-ZF3	4	2,5	10	30x11	50	Z	1
PRF1235*	PRF-A6-ZF3	6	2,5	15	30x11	50	Z	1
PRF9000	PRF-A3-SSF	3	2	6,2	20x11	50	SS	1

Utilizzare dadi tipo DAP con molla lunga (vedi pag. 105)

Profilo Inox (cod. PRF9000) forato solo sul fondo

*Su richiesta

Giunti per profili acciaio

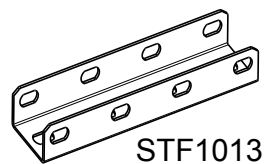
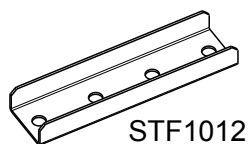

Codice	Riferimento	Da utilizzare per	F	
STF1012	STF-GI-PB-Inox	41x21	SS	20
STF1013	STF-GI-PA-Inox	41x41	SS	20

ESEMPIO DI MONTAGGIO

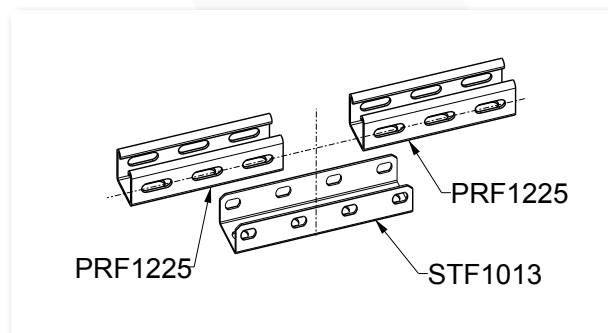
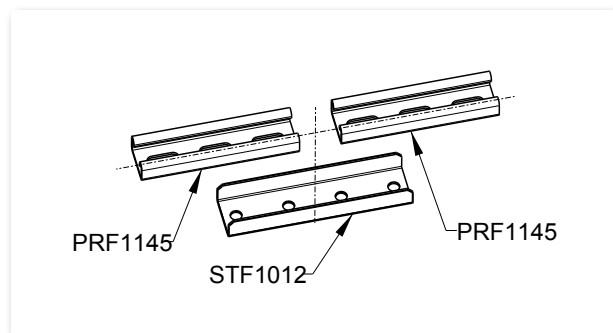

Ganasce a "Z" per fissaggio laterale

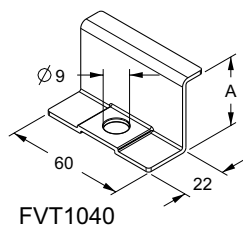

FVT1040

INOX AISI 304

Codice	Riferimento	A (mm)	Sp (mm)	
FVT1040	FVS-Z33-INOX	33	34	50
FVT1045	FVS-Z34-INOX	34	35	50
FVT1050	FVS-Z35-INOX	35	36	50
FVT1055	FVS-Z37-INOX	37	38	50
FVT1060	FVS-Z39-INOX	39	40	50
FVT1065	FVS-Z41-INOX	41	42	50
FVT1066	FVS-Z43-INOX	43	44	50
FVT1070	FVS-Z45-INOX	45	46	50
FVT1075	FVS-Z47-INOX	47	48	50
FVT1080	FVS-Z49-INOX	49	50	50

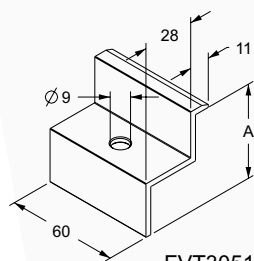

FVT3051

ALLUMINIO

Codice	Riferimento	A (mm)	Sp (mm)	
FVT3031	FVS-Z-31-ALU	31	29-30-31	50
FVT3034	FVS-Z-34-ALU	34	32-33-34	50
FVT3036	FVS-Z-36-ALU	36	35-36	50
FVT3039	FVS-Z-39-ALU	39	37-38-39	50
FVT3041	FVS-Z-41-ALU	41	40-41	50
FVT3044	FVS-Z-44-ALU	44	42-43-44	50
FVT3046	FVS-Z-46-ALU	46	45-46	50
FVT3049	FVS-Z-49-ALU	49	47-48-49	50
FVT3051	FVS-Z-51-ALU	51	50-51	50

Ganasce a "Ω" universali per fissaggio intermedio

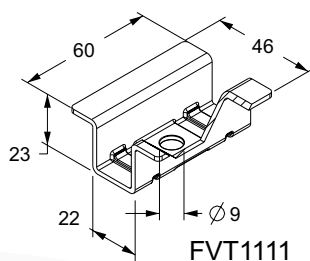

INOX AISI 304

Codice	Riferimento	
FVT1111	FVS-OM-U-EVO	100

Ganasce a "Ω" universali per fissaggio intermedio

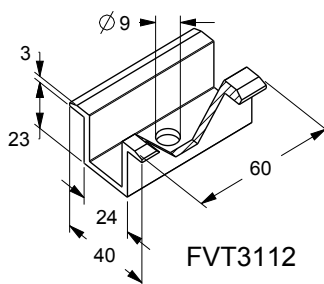

ALLUMINIO

Codice	Riferimento	
FVT3112	FVS-Ω-U-ALU	100

Piastrina fissaggio intermedio pannelli

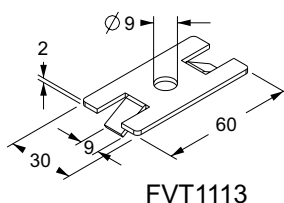

INOX AISI 304

Codice	Riferimento	
FVT1113	FVT-FPP-INOX	50

Per indicazioni sulla lunghezza delle viti da utilizzare per il montaggio, chiedere all'ufficio tecnico indicando lo spessore del modulo

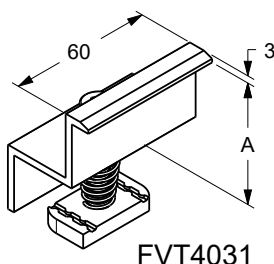

FVT4031

ALLUMINIO

Codice	Riferimento	A (mm)	Sp (mm)	
FVT4031	FVS-ZP-31-ALU	31	29-30-31	20
FVT4034	FVS-ZP-34-ALU	34	32-33-34	20
FVT4036	FVS-ZP-36-ALU	36	35-36	20
FVT4039	FVS-ZP-39-ALU	39	37-38-39	20
FVT4041	FVS-ZP-41-ALU	41	40-41	20
FVT4044	FVS-ZP-44-ALU	44	42-43-44	20
FVT4046	FVS-ZP-46-ALU	46	45-46	20
FVT4049	FVS-ZP-49-ALU	49	47-48-49	20
FVT4051	FVS-ZP-51-ALU	51	50-51	20

Ganasce a "Ω" per fissaggio intermedio-premontate

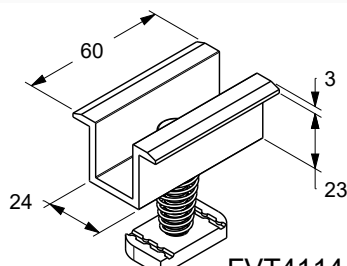

FVT4114

ALLUMINIO

Codice	Riferimento	
FVT4114	FVS-Ω-UP-ALU-29-35	50
FVT4115	FVS-Ω-UP-ALU-36-45	50
FVT4116	FVS-Ω-UP-ALU-46-51	50

Le tre versioni sono dedicate al range di spessori (mm) evidenziati nel riferimento.

Staffa tipo "S"

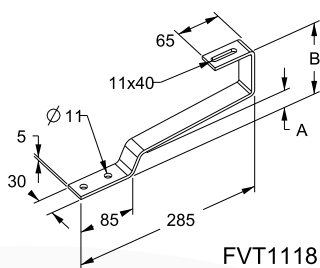

FVT1118

PER STAFFAGGIO SU CEMENTO

Codice	Riferimento	A (mm)	B (mm)	F	
FVT1118	FVSO-S-125-INOX	30	125	SS	16

Staffa tipo "S" regolabile

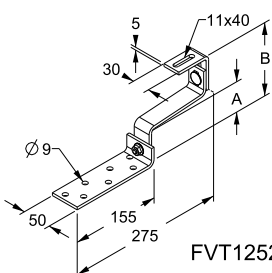

FVT1252

PER STAFFAGGIO SU LEGNO/CEMENTO

Codice	Riferimento	A (mm)	B (mm)	F	
FVT1252	FVSO-P-RGL-SS	50 min - 62 max	110 min - 145 max	SS	16

Staffa tipo "S" regolabile

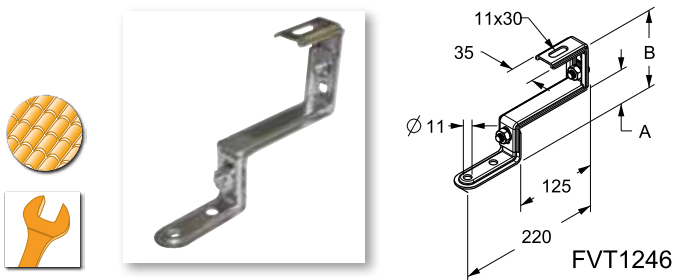

PER STAFFAGGIO SU CEMENTO

Codice	Riferimento	A (mm)	B (mm)	F	
FVT1246	FVS-S-RGL-EVO	48 min - 58 max	111 min - 145 max	SS	16
		* 57 min - 70 max	* 124 min - 145 max		

* : Misure ottenute invertendo il fissaggio della parte centrale

Staffa tipo "P" regolabile

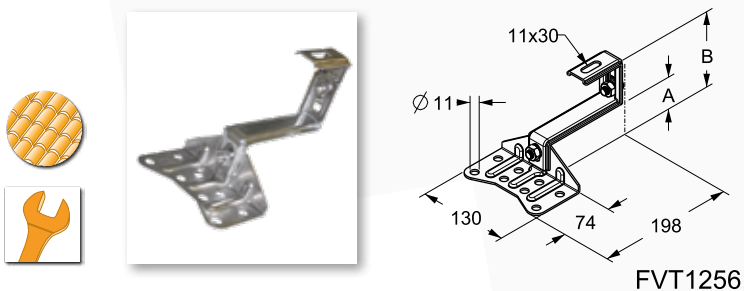

PER STAFFAGGIO SU LEGNO

Codice	Riferimento	A (mm)	B (mm)	F	
FVT1256	FVS-P-RGL-EVO	44 min - 56 max	114 min - 148 max	SS	16
		* 55 min - 66 max	* 126 min - 148 max		

* Misure ottenute invertendo il fissaggio della parte centrale

Staffa tipo "C" regolabile

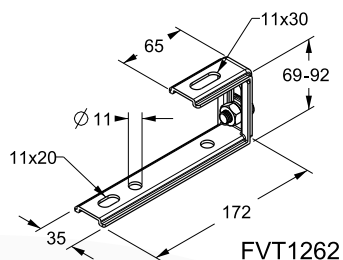

PER STAFFAGGIO SU CEMENTO

Codice	Riferimento	Regolazione (mm)	F	
FVT1262	FVS-CST-RGL-INOX	da 69 a 92	SS	20

Staffa tipo "R" regolabile

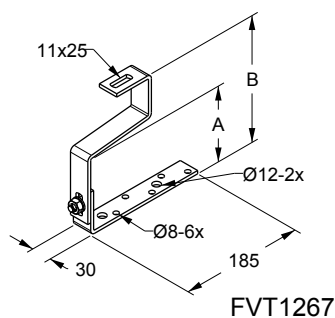

PER STAFFAGGIO SU LEGNO/CEMENTO

Codice	Riferimento	A (mm)	B (mm)	F	
FVT1267	FVS-R-RGL-INOX	94 min - 132 max	171 min - 209 max	SS	8

Staffe Inox a disegno per lamiere grecate

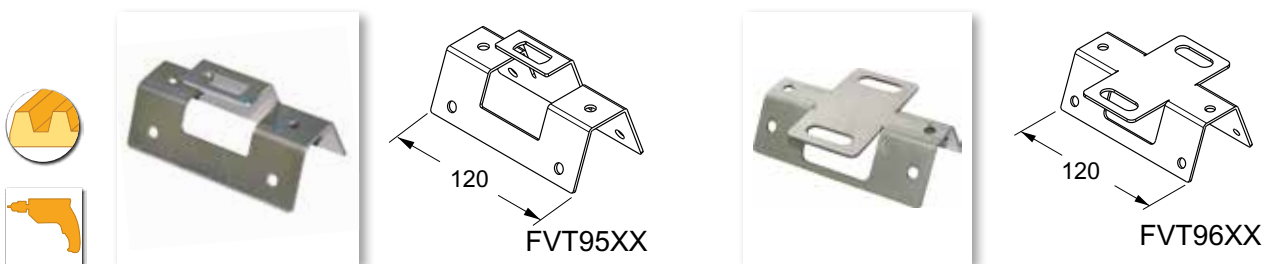

Codice	Riferimento	F	
FVT95XX	FVT-SLG-R	SS	1
FVT96XX	FVT-SLG-P	SS	1

Per la realizzazione della staffa è necessario indicare sempre le dimensioni delle greche della lamiera di copertura. Se possibile, meglio l'invio della relativa scheda tecnica. Si consiglia l'utilizzo della guarnizione in gomma neoprenica (vedi pag. 111).

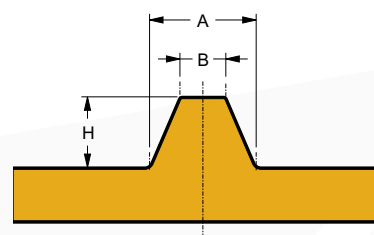

ESEMPIO DI MONTAGGIO STAFFE FVT95XX E FVT96XX

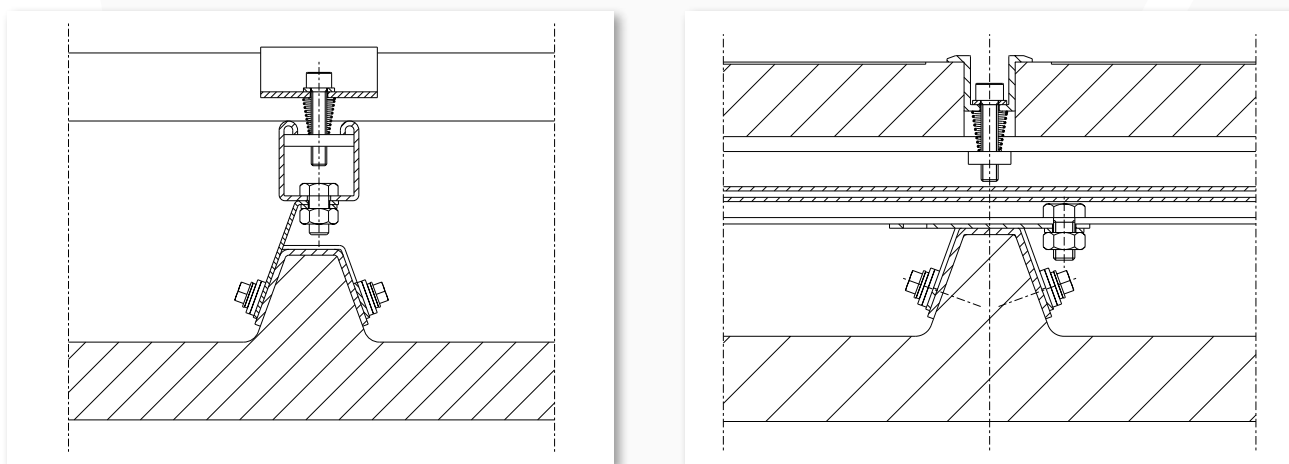

Morsetto Inox per lamiere aggraffate

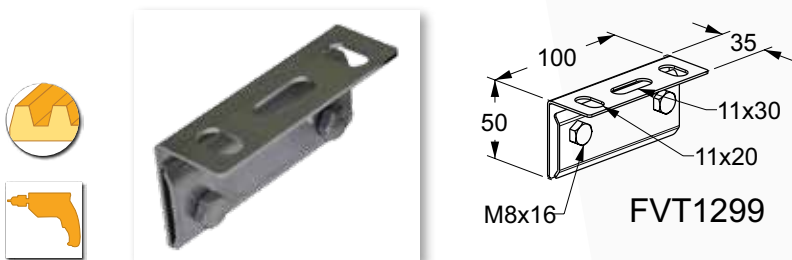

Codice	Riferimento	F	
FVT1299	FVT-SLG-MRS-INOX	SS	10

Completo di dadi e viti TE M8x16-coppia di serraggio max 40 N/m.

Kit universali per lamiera grecata e pannello sandwich

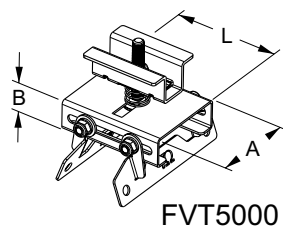

FVT5000

KIT PREMONTATO PER FISSAGGIO MODULO ORIZZONTALE INOX AISI 304

Codice	Riferimento	A (mm)	B (mm)	L (mm)	F	
FVT5000	FVT-SLG-U080-INOX	63	23	80	SS	20
FVT50XX	Dima di fissaggio	Fornire la Larghezza del pannello			S	1

Per il serraggio della staffa utilizzare chiave a bussola tipo Beta serie 900L o chiave a bussola tipo Usag codice 235543 da 13 mm.
Per la coppia di serraggio attenersi a quanto prescritto dal produttore del modulo.

ESEMPIO DI MONTAGGIO

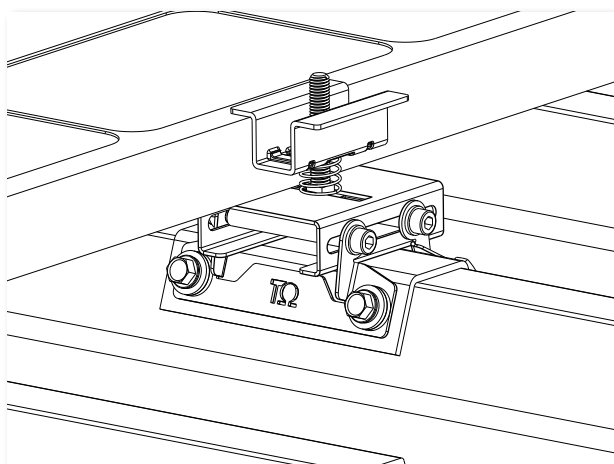

Patent pending



Compensatore laterale

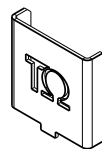

FVT5041

INOX AISI 304

Codice	Riferimento	A (mm)	Sp* (mm)	
FVT5030	FVS-UP-30-INOX	30	29-30-31	20
FVT5033	FVS-UP-33-INOX	33	32-33-34	20
FVT5036	FVS-UP-36-INOX	36	35-36	20
FVT5038	FVS-UP-38-INOX	38	37-38-39	20
FVT5041	FVS-UP-41-INOX	41	40-41	20
FVT5043	FVS-UP-43-INOX	43	42-43-44	20
FVT5046	FVS-UP-46-INOX	46	45-46	20
FVT5048	FVS-UP-48-INOX	48	47-48-49	20
FVT5051	FVS-UP-51-INOX	51	50-51	20

* Spessore del modulo fotovoltaico utilizzato.

Viti autoperforanti - autofilettanti per staffe lamiera grecata

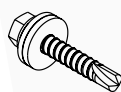

FVT1545

Codice	Riferimento	M	F	
FVT1545	FVT-VLG-6x25-INOX	6	SS	100

Complete di guarnizione in EPDM

Profili ALU per lamiera grecata o pannello sandwich

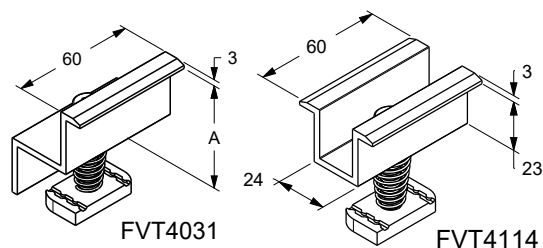
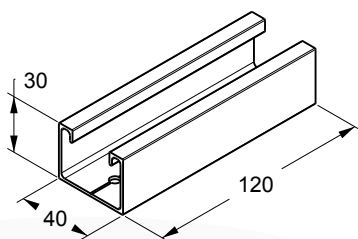

Da ordinare separatamente (vedi pag. 90)

Spezzone di profilo ALU per fissaggio pannelli in orizzontale

Codice	Riferimento	L (mm)	Sp (mm)	Peso (kg)	
FVT5120	FVP-L120-RI-ALU	120	1,6	0,062	16

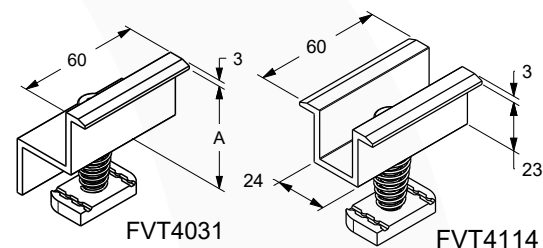
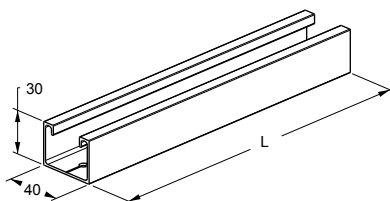

Da ordinare separatamente (vedi pag. 90)

Spezzone di profilo ALU per fissaggio pannelli in verticale

Codice	Riferimento	L (mm)	Sp (mm)	Peso (kg)	
FVT5250	FVP-L230-RI-ALU	230	1,6	0,123	16
FVT5300	FVP-L280-RI-ALU	280	1,6	0,150	16
FVT5400	FVP-L363-RI-ALU	363	1,6	0,194	16

ESEMPI DI MONTAGGIO

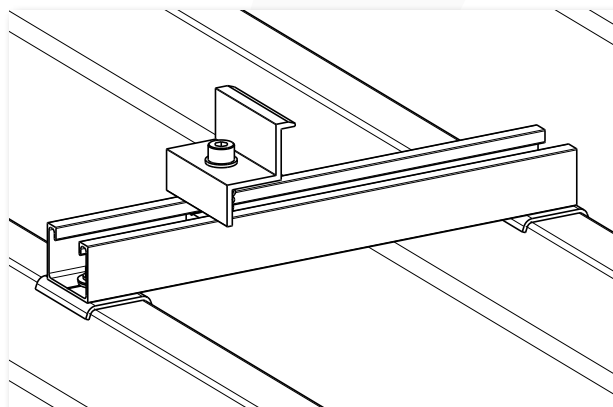
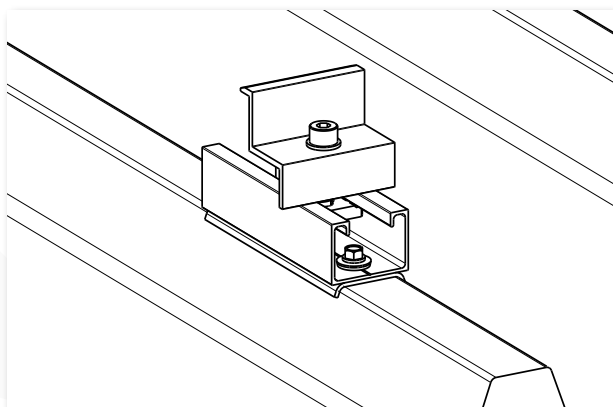

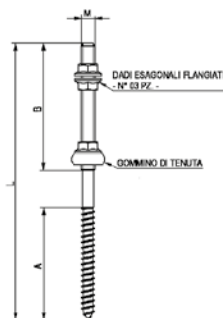

STAFFAGGIO SU LEGNO O CEMENTO

Codice	Riferimento	M	A (mm)	B (mm)	L (mm)	F	
FVT1300	FVA-AF-10X200-INOX	M10	67	110	200	SS	50
FVT1305	FVA-AF-10X250-INOX	M10	67	125	250	SS	50
FVT1310	FVA-AF-12X250-INOX	M12	100	120	250	SS	50
FVT1315	FVA-AF-12X300-INOX	M12	100	170	300	SS	50
FVT1316	FVA-AF-12X350-INOX	M12	100	215	350	SS	50

Dadi - rondelle - guarnizioni incluse. Per impiego su cemento utilizzare un tassello idoneo

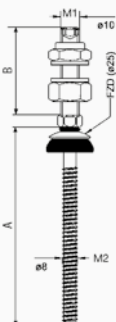

Ø mm preforo per fissaggio su metallo	
Sp struttura (mm)	Preforo (mm)
5,0 ≤ 7,5	7
7,5 ≤ 10	7,2
≥ 10	7,4

FISSAGGIO METALLO

Codice	Riferimento	M1	M2 (mm)	A (mm)	B (mm)	F	
FVT1318	FVA-AF-100-50M10-INOX	M10	8	100	50	SS	25
FVT1319	FVA-AF-150-50M10-INOX	M10	8	150	50	SS	25

Dadi - rondelle - guarnizioni incluse

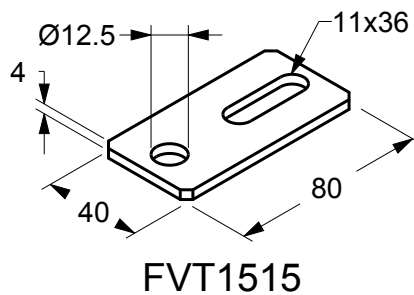

PIASTRINA DI FISSAGGIO

Codice	Riferimento	F	
FVT1515	FVT-P2-SS	SS	50

ESEMPI DI MONTAGGIO

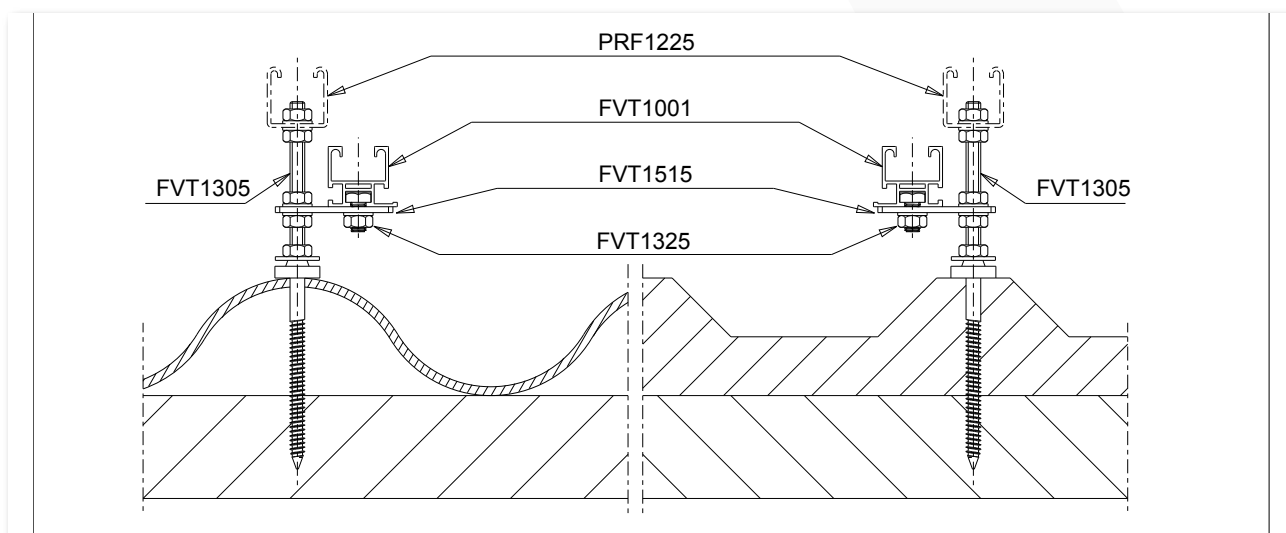

Triangolo supporto pannelli

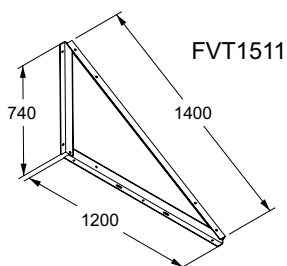

FVT1511

MODULO IN VERTICALE

Codice	Riferimento	Angolo	F	
FVT1511	FVT-TRG-R-EVO	30°-35°-40°-45°	ALU	1

Cod. FVT1511 da utilizzare in abbinamento a zavorra in cemento (FVT1457)

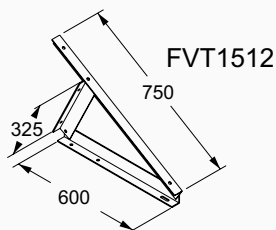

FVT1512

MODULO IN ORIZZONTALE

Codice	Riferimento	Angolo	F	
FVT1512	FVT-TRG-OR	30°	ALU	1

Cod. FVT1512 da utilizzare in abbinamento a zavorra in cemento (FVT1457)

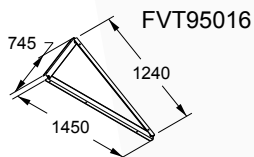

FVT95016

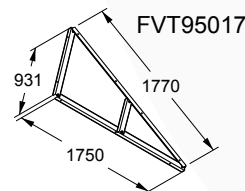

FVT95017

TRIANGOLO UTILIZZATO CON ZAVORRE

Codice	Riferimento	Angolo	Orientamento pannello	Numero di pannelli	F	
FVT95016	FVT-TSV	30°	Verticale	Singolo	ALU	1
FVT95017	FVT-TDH	30°	Orizzontale	Doppio	ALU	1

Per inclinazioni differenti, contattare il nostro U.T. per info circa le tempistiche e le minime quantità.

Triangolo doppio

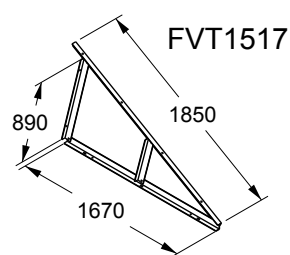
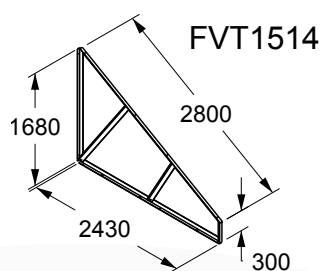
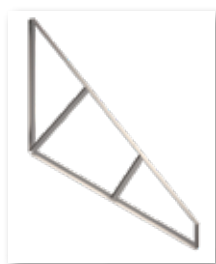

TRIANGOLO UTILIZZATO CON TASSELLI

Codice	Riferimento	Angolo	Orientamento pannello	Numero di pannelli	F	
FVT1514	FVT-TRG-DP	30°	Verticale	Doppio	ALU	1
FVT1517	FVT-TRG-DP-O	30°	Orizzontale	Doppio	ALU	1

Triangoli disponibili a richiesta.

Controvento per triangoli

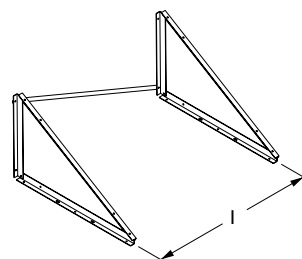

Codice	Riferimento	l (m)	F	
FVT1286	FVT-SCV-ALU	1,5	ALU	10
FVT1287	FVT-SCV-S-ALU	1	ALU	10
FVT1288	FVT-SCV-C-ALU	1	ALU	10

FVT1287: controvento per triangolo FVT1511, FVT1517, FVT95016 e FVT95017.
FVT1288: controvento per triangolo FVT1512

Su richiesta controventi Alu a lunghezza specifica

Per fissaggio ai triangoli consigliamo viti TCEI M10x30 (cod. FVT1347)

ESEMPI DI MONTAGGIO

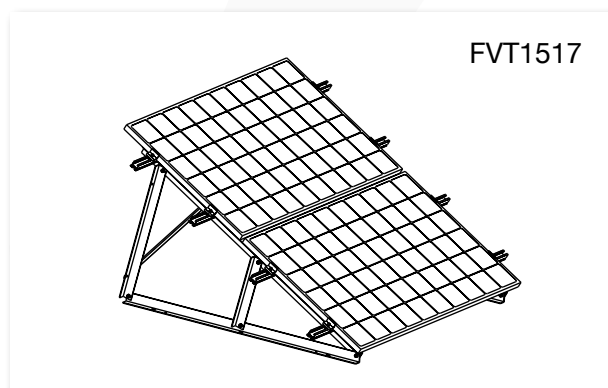
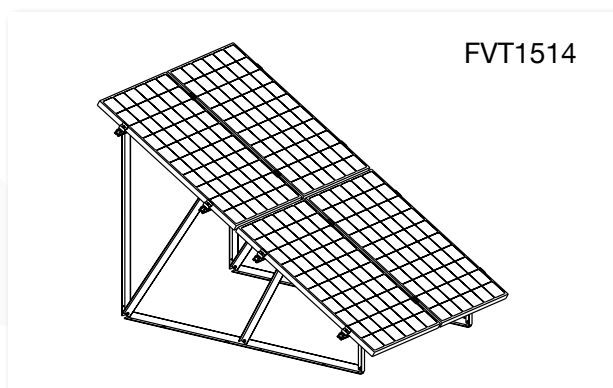

Zavorre in cemento

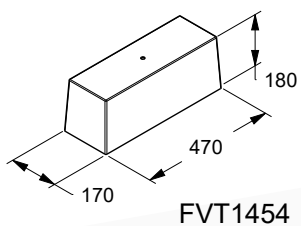
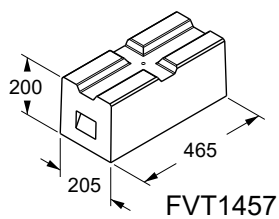

Codice	Riferimento	Peso (kg)	
FVT1457	FVV-ZVC	40	1
FVT1454	FVV-ZVC-30	30	1

Zavorre fornite con un inserto centrale da M10x30.
Per applicazioni con zavorre vedi pag. 115



Zavorre in cemento

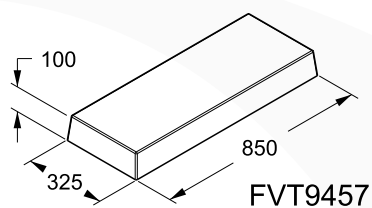
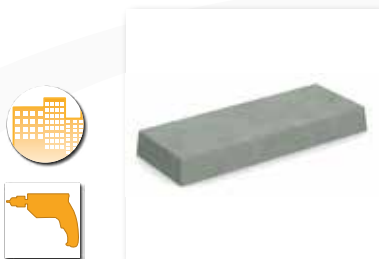
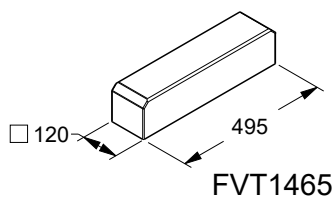

Codice	Riferimento	Peso (kg)	
FVT1465	FVV-ZVC-1002	14	1
FVT9457	FVV-ZMP-C	60	1

Zavorre in cemento - Sistema Flat

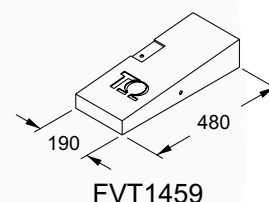
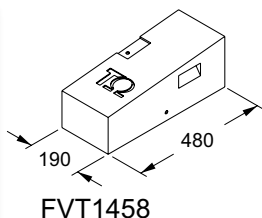
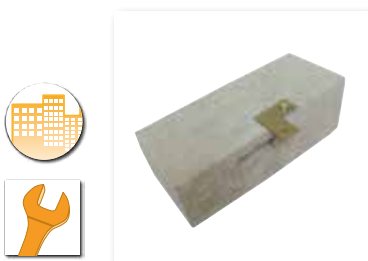

SISTEMA FLAT

Codice	Riferimento	Peso (kg)	
FVT1458	FVV-ZVC-30-1	33	1
FVT1459	FVV-ZVC-30-2	18	1

Con inserti filettati M10
 Staffa e viteria di fissaggio INOX inclusa
 Proiezione H max 30cm utilizzando profilo di fissaggio H 41
 con modulo 1660x990 - sp. 50
 Per istruzioni di montaggio vedi pagina 115



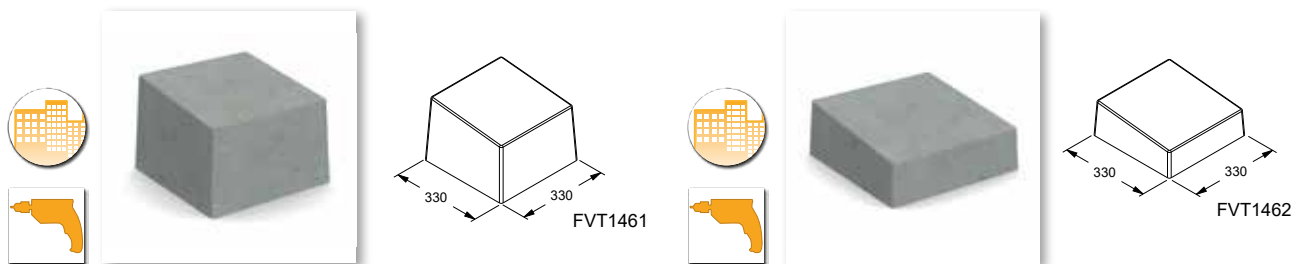

Zavorre in cemento con inclinazione 6°

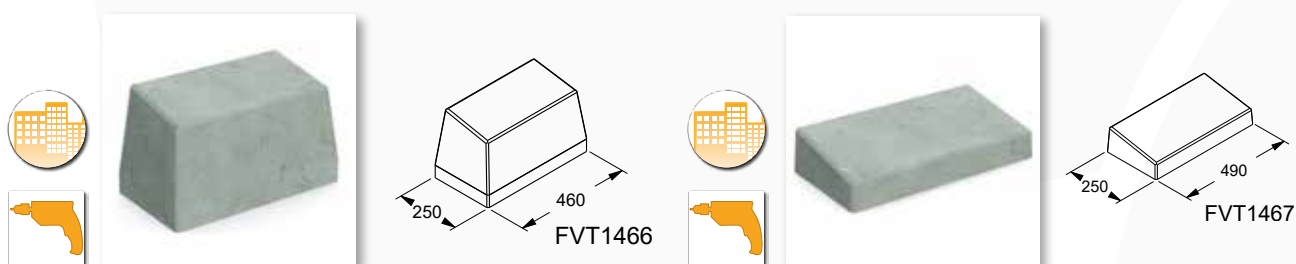

Codice	Riferimento	Peso (kg)	Angolo	
FVT1461	FVV-ZVC-6-52	52	6°	1
FVT1462	FVV-ZVC-6-28	28	6°	1

Zavorre in cemento con inclinazione 10°



Codice	Riferimento	Peso (kg)	Angolo	
FVT1466	FVV-ZVC-10-62	62	10°	1
FVT1467	FVV-ZVC-10-25	25	10°	1



Spessore 6 mm - Diametro fori 14 mm

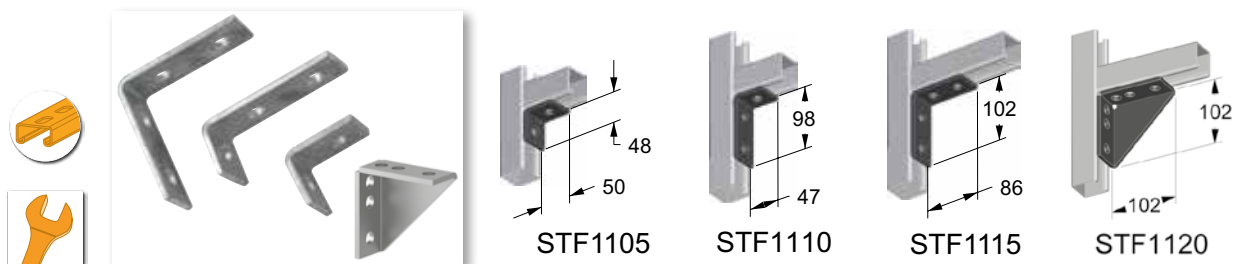

STAFFE ANGOLARI A 90°

Codice	Riferimento	
STF1105	STF-WL2	10
STF1110	STF-WL3	10
STF1115	STF-WL4	10
STF1120	STF-WL4R	10



STAFFA A 45°

Codice	Riferimento	
STF1100	STF-W45	10



STAFFA PER INCLINAZIONE 30°

Codice	Riferimento	
STF1101	STF-W30A	10
STF1102	STF-W30-90A	10

Spessore 6 mm - Diametro fori 14 mm

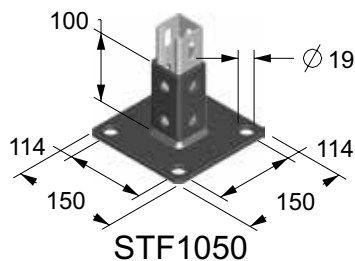

STAFFA PIASTRA BASE

Codice	Riferimento	
STF1050	STF-B41	1

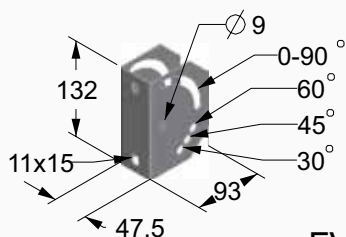

FVT1270

STAFFA AD ANGOLAZIONE VARIABILE

Codice	Riferimento	
FVT1270	FVS-AV-ZC	10

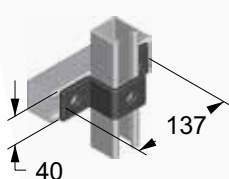

STF1025

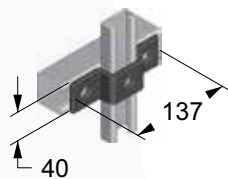

STF1030

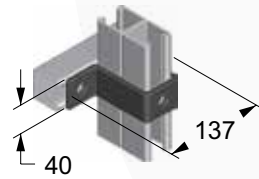

STF1035

STAFFE AD "OMEGA"

Codice	Riferimento	
STF1025	STF-041	10
STF1030	STF-021	10
STF1035	STF-82	10

Spessore 6 mm - Diametro fori 14 mm - Zincate a caldo

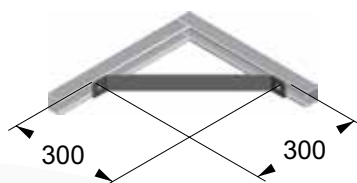

STF1140

STAFFA DI RINFORZO A SAETTA

Codice	Riferimento	
STF1140	STF-SR300	10

Dadi STRUT con molla



ZINCATI A CALDO

Codice	Riferimento	M		F	Sp (mm)
DAP2000	DAP-M6-S-ZC	M6	100	Z	6,5
DAP2005	DAP-M8-S-ZC	M8	100	Z	6,5
DAP2010	DAP-M10-S-ZC	M10	100	Z	8
DAP2020	DAP-M6-C-ZC	M6	100	Z	6,5
DAP2025	DAP-M8-C-ZC	M8	100	Z	6,5
DAP2030	DAP-M10-C-ZC	M10	100	Z	8
DAP2040	DAP-M6-L-ZC	M6	100	Z	6,5
DAP2045	DAP-M8-L-ZC	M8	100	Z	6,5
DAP2050	DAP-M10-L-ZC	M10	100	Z	8

INOX AISI 304

Codice	Riferimento	M		F	Sp (mm)
DAP3005	DAP-M8-S-SS	M8	100	SS	6,5
DAP3010	DAP-M10-S-SS	M10	100	SS	8
DAP3025	DAP-M8-C-SS	M8	100	SS	6,5
DAP3030	DAP-M10-C-SS	M10	100	SS	8
DAP3045	DAP-M8L-SS	M8	100	SS	6,5
DAP3050	DAP-M10L-SS	M10	100	SS	8

Vite testa martello

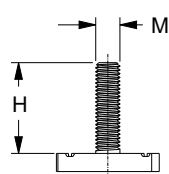

FVT1395

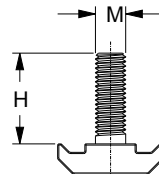

FVT1400

ZINCATURA ELETTROLITICA

Codice	Riferimento	MxH	
FVT1395	FVA-TM-8X30-E	M8x30	100
FVT1400	FVA-TM-10X30-E	M10x30	100

Kit Vite TCEI con rondella

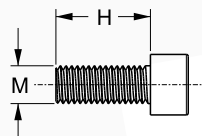
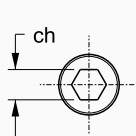

INOX AISI 304

Codice	Riferimento	MxH	ch (mm)	
FVT1330	FVA-TCEI-8x10-INOX	M8x10	6	100
FVT1331	FVA-TCEI-8x60-INOX	M8x60	6	100
FVT1332	FVA-TCEI-8x20-INOX	M8x20	6	100
FVT1333	FVA-TCEI-8x65-INOX	M8x65	6	100
FVT1334	FVA-TCEI-8x75-INOX	M8x75	6	100
FVT1335	FVA-TCEI-8x25-INOX	M8x25	6	100
FVT1337	FVA-TCEI-8x30-INOX	M8x30	6	100
FVT1338	FVA-TCEI-8x35-INOX	M8x35	6	100
FVT1340	FVA-TCEI-8x40-INOX	M8x40	6	100
FVT1341	FVA-TCEI-8x45-INOX	M8x45	6	100
FVT1342	FVA-TCEI-8x50-INOX	M8x50	6	100
FVT1343	FVA-TCEI-8x55-INOX	M8x55	6	100
FVT1344	FVA-TCEI-8x70-INOX	M8x70	6	100
FVT1345	FVA-TCEI-10x25-INOX	M10x25	8	100
FVT1346	FVA-TCEI-10x20-INOX	M10x20	8	100
FVT1347	FVA-TCEI-10x30-INOX	M10x30	8	100
FVT1350	FVA-TCEI-10x40-INOX	M10x40	8	100
FVT1355	FVA-TCEI-10x50-INOX	M10x50	8	100

Kit Vite TE con dado e rondella

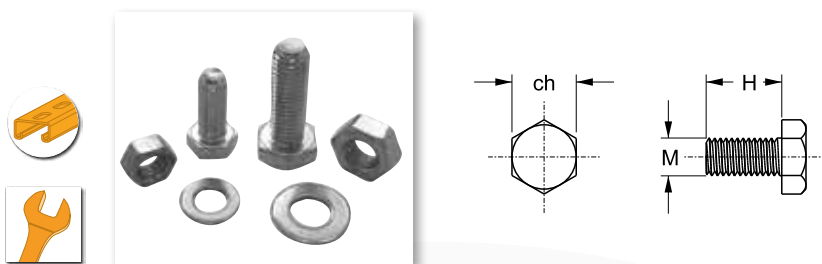

INOX AISI 304

Codice	Riferimento	MxH	ch (mm)	
FVT1320	FVA-TE-8x16-INOX	M8x16	13	100
FVT1325	FVA-TE-10x20-INOX	M10x20	17	100

Kit dado e rondella

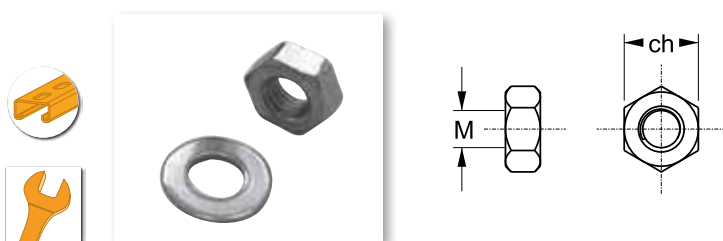

INOX AISI 304

Codice	Riferimento	M	ch (mm)	
FVT1358	FVA-DR-M8-INOX	M8	13	100
FVT1359	FVA-DR-M10-INOX	M10	17	100

Sfera antifurto per viti TCEI M8



INOX AISI 304

Codice	Riferimento	
FVT1356	FVA-SA-8-INOX	100

Diametro sfera = 6,35 mm

Barra filettata

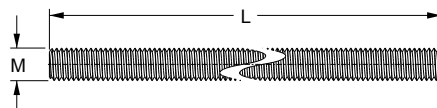

INOX AISI 304

Codice	Riferimento	F	M	L (mm)	
FVT1405	FVA-BF-M8-INOX	SS	M8	1000	10
FVT1410	FVA-BF-M10-INOX	SS	M10	1000	10

Manicotto filettato

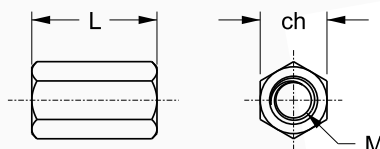

INOX AISI 304

Codice	Riferimento	F	M	ch (mm)	L (mm)	
FVT1415	FVA-MF-8x30-INOX	SS	M8	13	30	10
FVT1420	FVA-MF-10x30-INOX	SS	M10	17	30	10

Rivetti a fiore con guarnizione

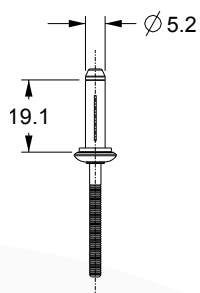
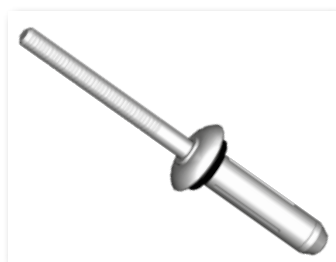

ALLUMINIO

Codice	Riferimento	D (mm)	L (mm)	H (mm)	
FVT9470	RIV-ST-52-191-ALU	5,2	19,1	1,5 ÷ 6,4	100

Foro di montaggio Ø 5,5 mm



Viti autofilettanti per calcestruzzo

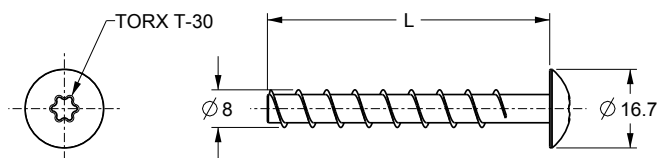

Codice	Riferimento	D (mm)	L (mm)	
FVT9200	FVA-VAC-8-80	8	80	100
FVT9201	FVA-VAC-8-60	8	60	100

Preforo: Ø 6 mm

Inserito antifurto



Codice	Riferimento	
FVT9210	FVA-VAC-IA	100

Da utilizzare con viti autofilettanti per calcestruzzo a codice FVT9200 e FVT9201

Tappi in plastica per profili STRUT



Codice	Riferimento	
BUL1020	BUL-TP21	100
BUL1025	BUL-TP41	100

Guarnizioni in neoprene in rotoli

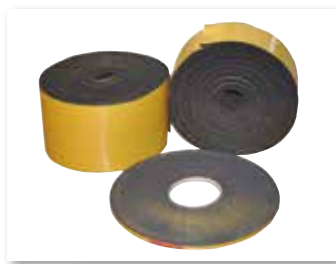

Codice	Riferimento	Dimensioni (mm)	Utilizzo	
FVT1530	FVT-GN-120	120x3 (x10 m)	Saffe x lamiera grecata	1
FVT1535	FVT-GN-80	80x3 (x10 m)	Staffe x lamiera grecata	1

Guarnizioni butiliche e bituminose



Codice	Riferimento	Dimensioni (mm)	Materiale	Utilizzo	
FVT1550	FVT-GBU-50	50x1,5 (x10 m)	Nastro Butilico retato	Sotto staffe e profilati	1
FVT1551	FVT-GBU-10	10x1,5 (x10 m)	Nastro Butilico retato	Sotto staffe e profilati	1
FVT1552	FVT-GBU-120	120x1,5 (x10 m)	Nastro Butilico retato	Sotto staffe e profilati	1
FVT1558	FVT-MG-1200	1200x1,5 (x10m)	Gomma nera SBR	Appoggio zavorre	1

Componenti elettrici



BIPOLARI 125A

CARATTERISTICHE TECNICHE

Conduttore

Testata e certificata x impieghi fino a 1000V DC
 Viti incluse.
 Protezione isolante tra le fasi
 Struttura isolante autoestinguente: UL 94V0
 Innesto rapido su guide DIN
 Icw secondo standard IEC 947-7-1
 RPB1005: ingressi destro o sinistro



Codice	Riferimento	Peso (kg)	L (mm)	H (mm)	P (mm)	Interasse fori (mm)	
RPB1005	RPB 125-14	0,206	132	45	51	112	1

TABELLA TECNICA

Codice	IN/OUT	Cavo (mm ²)	Puntale (mm ²)	N°	Ø (mm)	 (Nm)	Icw rms 1s (kA)	Ipk (kA)	Ui (V)
RPB1005	IN →	10 ÷ 35	10 ÷ 25	1	9,0	2 - 3	4,2	20	500
	IN - OUT ↔	10 ÷ 35	10 ÷ 25	1	9,0	2 - 3			
	← OUT	2,5 ÷ 6	1,5 ÷ 6	11	5,5	2 - 3			
	← OUT	10 ÷ 25	6 ÷ 16	2	7,5	2 - 3			

La morsettiere bipolare RPB1005 testata e certificata per utilizzo in DC è una soluzione ottimale per collettare i cavi di stringa

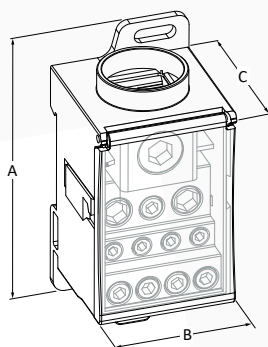

CARATTERISTICHE TECNICHE

Corpo isolante: PA 66 UL 94-V0, grigio RAL 7035
 Coperchio: PC UL 94-V0 giallo trasparente: Ottone
 Corpo conduttore RPU3010: Ottone
 Corpo conduttore RPU3015: Rame stagnato
 Morsetti: acciaio zincato e alluminio
 Viti: acciaio zincato
 Grado di protezione IP20
 Conformità alla norma EN 60947-7-1
 Certificazione secondo norma UL 1059

UNIPOLARE 250A - 400A

Codice	Riferimento		In (A)		Peso (Kg)	A (mm)	B (mm)	C (mm)
			IEC/EN	UL				
RPU3010	RPU 250-11 S	1	250	230	0,331	96	47	50
RPU3015	RPU 400-11 S	1	400	310	0,358	96	47	50

DATI TECNICI

Codice	Tipo	IN/OUT	COFLEX* L (mm)	Sez. cavo nudo (mm ²)	Sez. cavo con puntalino (mm ²)	Nr	Dim. (mm)	 (Nm)	Icw (kA)	Ipk (kA)	Ui (V)	
											IEC/EN	UL
RPU3010	Unipolare 11 uscite 250 A	IN	13-15,5	35 ÷ 120	35 ÷ 95	1	16x14	14	21	51	1000	600
		OUT	-	6 ÷ 35	6 ÷ 25	2	Ø 9	10				
		OUT	-	2,5 ÷ 16	2,5 ÷ 16	5	Ø 6,8	6				
		OUT	-	2,5 ÷ 10	2,5 ÷ 10	4	Ø 6,1	3				
RPU3015	Unipolare 11 uscite 400 A	IN	15,5-20	95 ÷ 185	95 ÷ 120	1	20,5x16	25	21	51	1500	600
		OUT	-	6 ÷ 35	6 ÷ 25	2	Ø 9	10				
		OUT	-	2,5 ÷ 16	2,5 ÷ 16	5	Ø 6,8	6				
		OUT	-	2,5 ÷ 10	2,5 ÷ 10	4	Ø 6,1	3				

Icc pk = Valore di picco della corrente di corto circuito

Ui = Tensione di isolamento nominale

Icw = Corrente massima ammissibile di breve durata, pari a 1 secondo, secondo EN 60947-7-1

* Consultare le tabelle delle barre flessibili COFLEX

Certificazioni disponibili a richiesta.

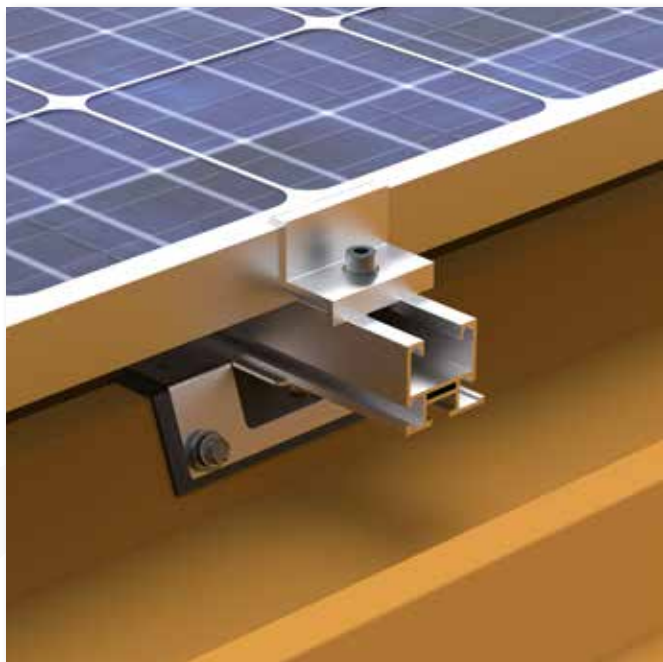

Applicazione modulo verticale con staffa FVT96XX (guarnizione FVT1530) e profilato Alu FVT1021.

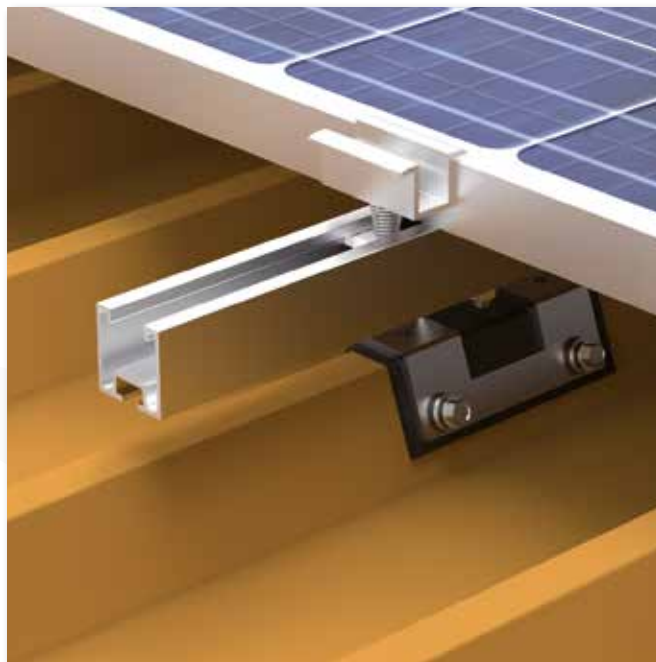

Applicazione modulo orizzontale con staffa FVT95XX (guarnizione FVT1530) e profilato FVT1021.

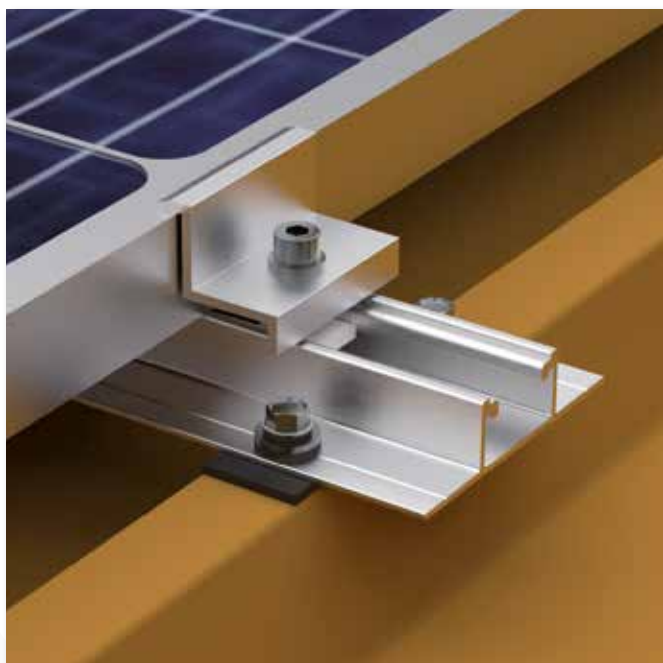

Applicazione modulo verticale con profilato Alu FVT1016 fissato con viti auto perforanti filettanti (guarnizione Butilica FVT1550). La guarnizione auto agglomerante tende ad "impastare" il filetto della vite aumentando l'impermeabilizzazione.

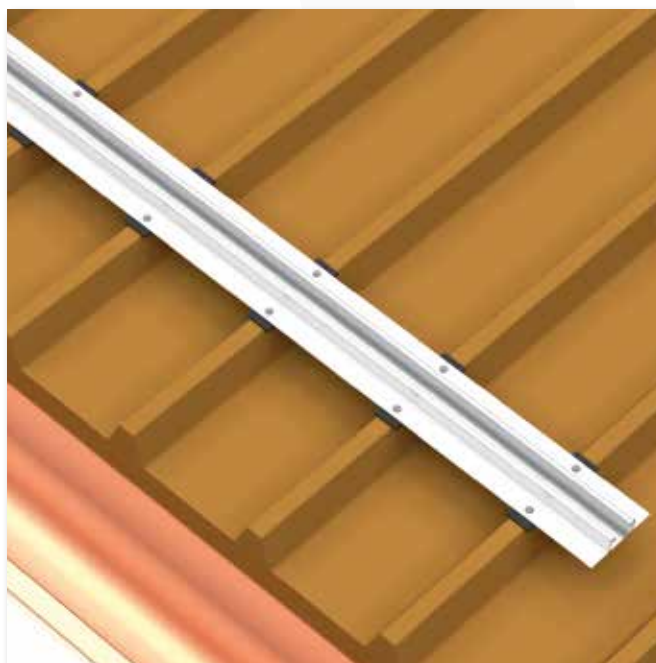

Il profilato FVT1016 può essere fissato anche per mezzo di rivetti a fiore in alluminio FVT9470. Dopo una partenza a doppio rivetto si suggerisce la sequenza alternata (consigliata guarnizione Butilica FVT1550).

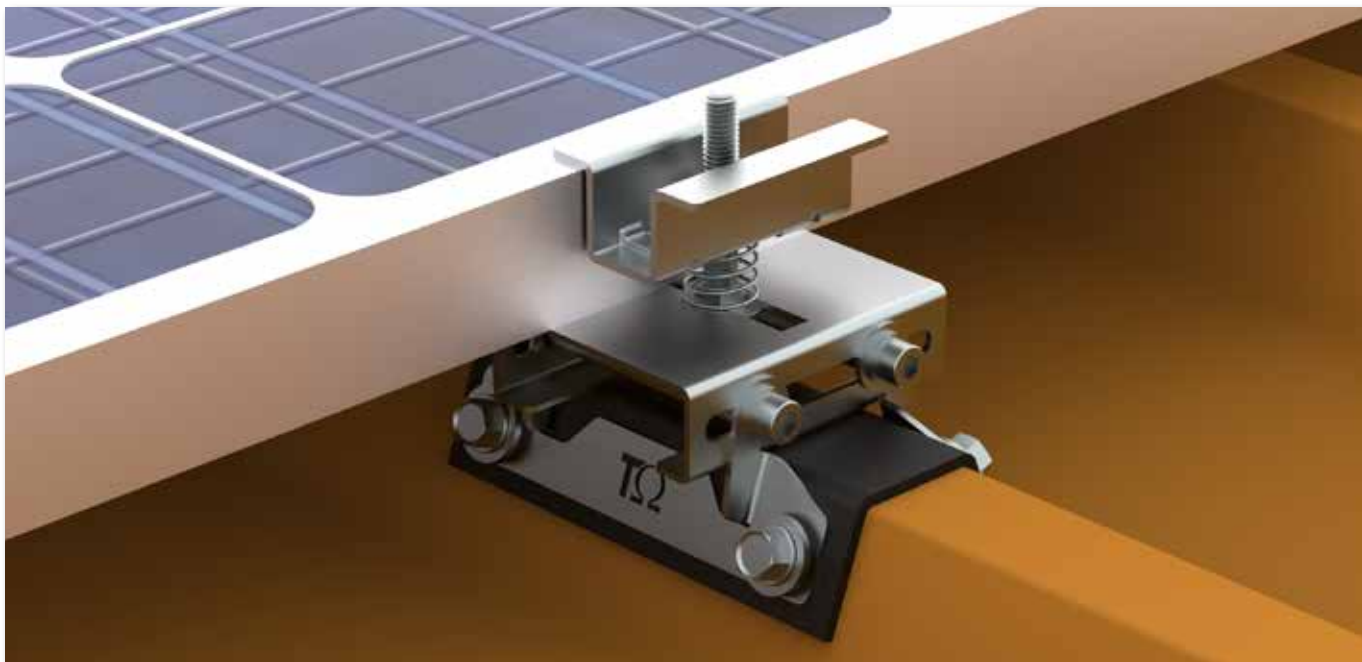

FVT5000 è un sistema universale per il fissaggio orizzontale di moduli fotovoltaici su lamiere grecate con diverse sezioni ed inclinazioni. Questa nuova soluzione non prevede l'utilizzo di profilato, è venduta in kit pre-montati INOX AISI 304 e con l'ausilio della guarnizione butilica FVT1552 rende l'installazione rapida e sicura.

Patent pending



Applicazione per moduli orizzontali

Tipica installazione con zavorre in cemento FVT1457, triangoli FVT1512 regolati a 30° e profilato semplice Ω Alu FVT1021.

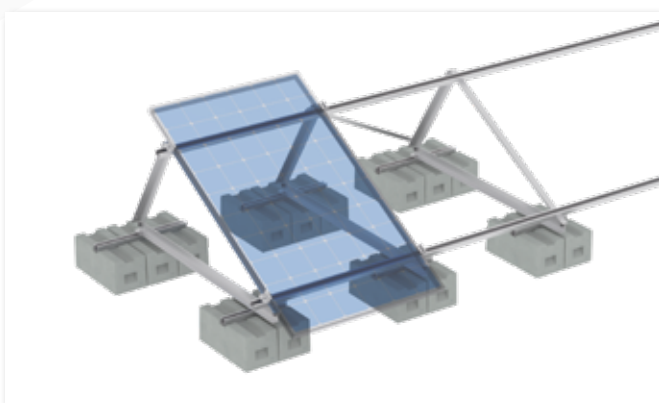

Applicazione per moduli verticali

Tipica installazione con zavorre in cemento FVT1457, triangoli FVT1511 regolati a 30° profilato semplice Ω Alu FVT1021.

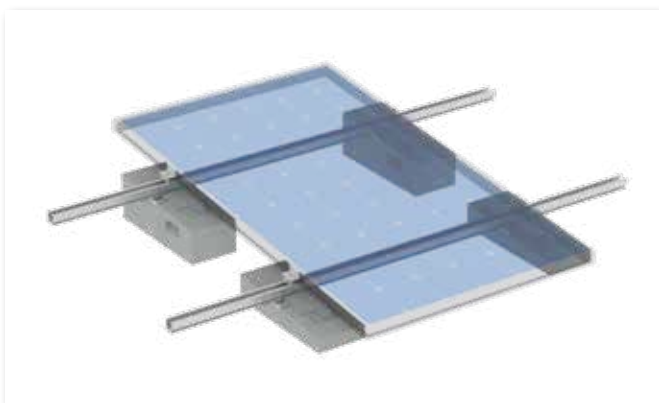

Applicazione per moduli verticali

Tipico a interasse 800 mm con zavorre inclinate in cemento FVT1458-FVT1459, profilato semplice Ω Alu FVT1021. Questo sistema garantisce una proiezione max di 30 cm (vedi pag. 101).

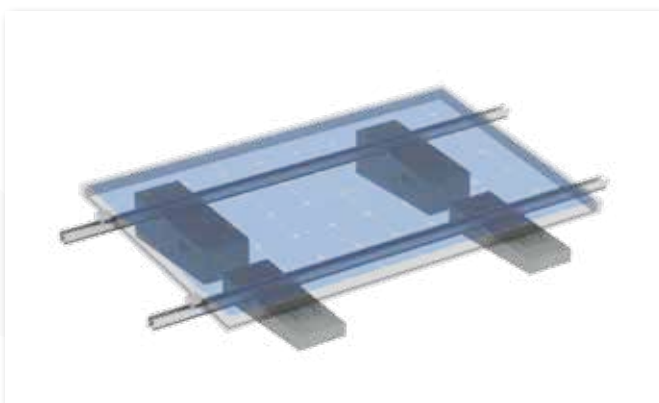
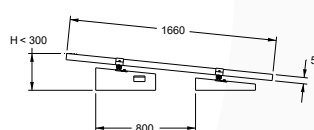

Applicazione per moduli orizzontali

Tipico a interasse 600 mm con zavorre inclinate in cemento FVT1458-FVT1459, profilato semplice Ω Alu FVT1021. Questo sistema garantisce una proiezione max di 30 cm. (vedi pag. 101).

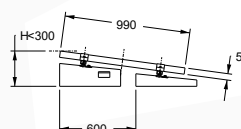

NOTA BENE Tutte le applicazioni che prevedono l'utilizzo di zavorre devono essere dimensionate in conformità alla normativa vigente.

Esempi di fissaggio su tetto piano

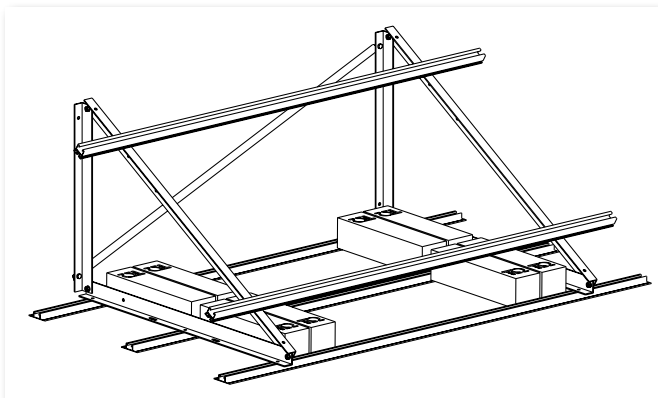

Applicazione per moduli verticali

Tipica installazione con binario FVT1016 zavorrato con FVT1465, triangoli FVT1511 regolati a 30° e profilato semplice Ω Alu FVT1021.

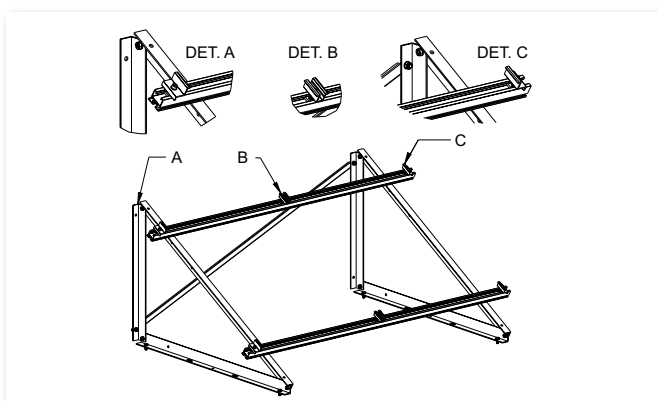

Installazione delle ganasce

Montaggio delle ganasce " Ω intermedia" e "Z laterale" su profilati alluminio o acciaio zincato caldo. L'assemblaggio può essere eseguito con vite TCEI con rondella e dado rettangolare con molla o utilizzando kit pre assemblati. Per la coppia di serraggio delle viti delle ganasce, attenersi a quanto prescritto dal fornitore dei moduli fotovoltaici.

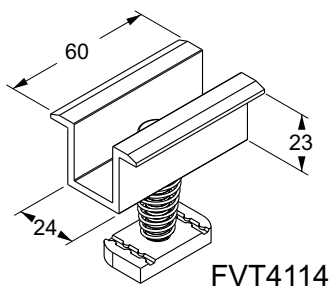

FVT4114

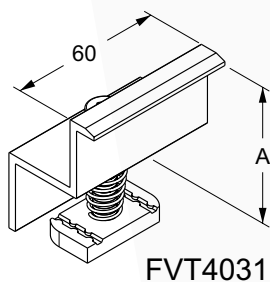

FVT4031

NOTA BENE

Tutte le applicazioni che prevedono l'utilizzo di zavorre devono essere dimensionate in conformità alla normativa vigente.

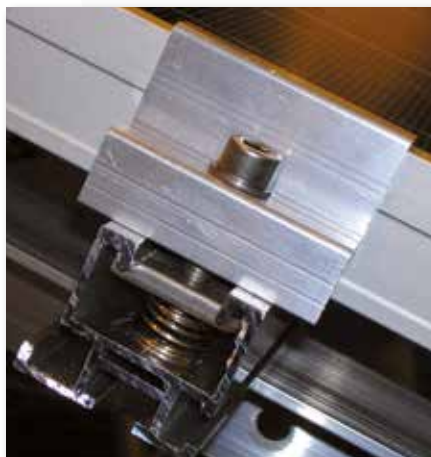

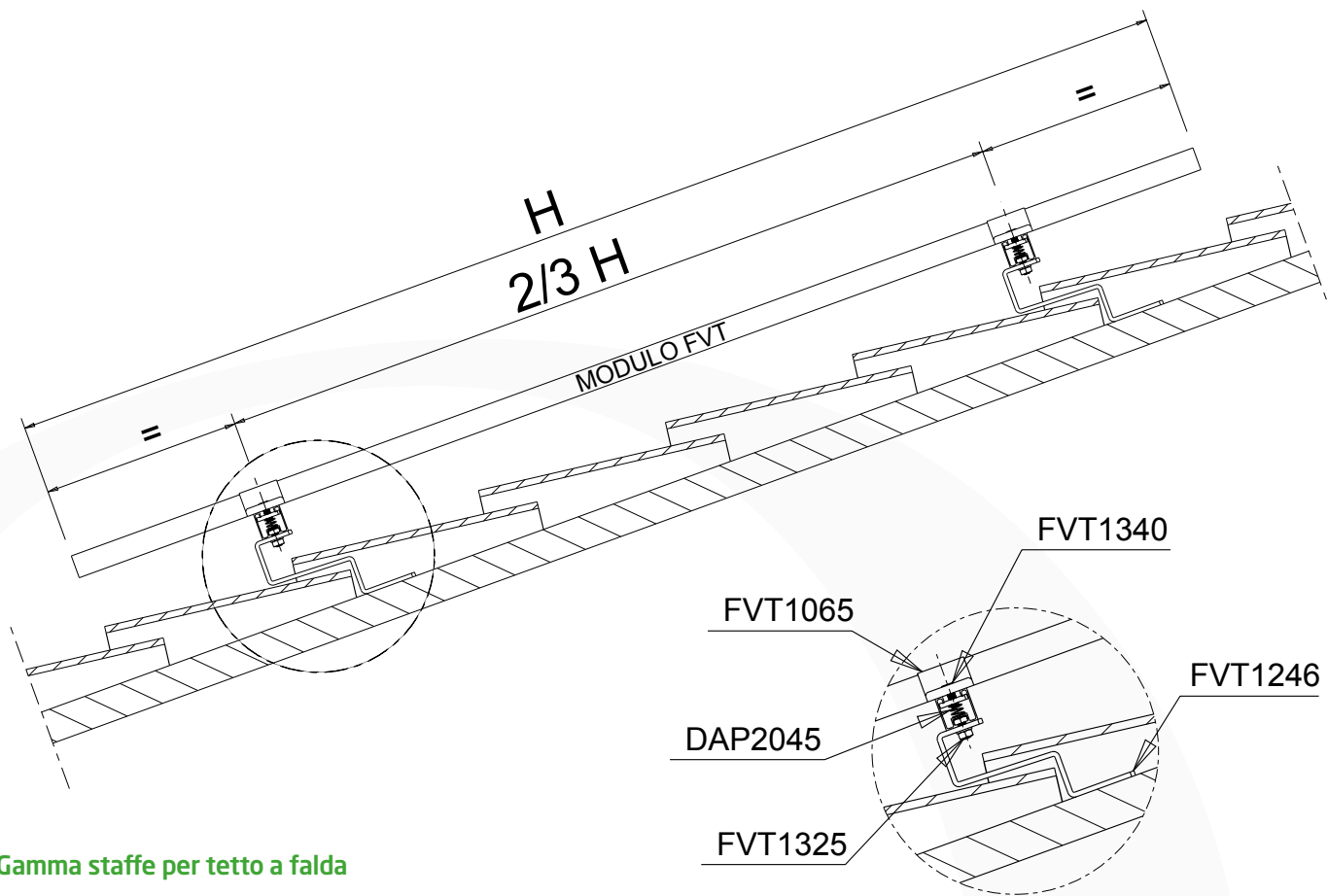

Gamma staffe per tetto a falda

Per staffaggio su cemento

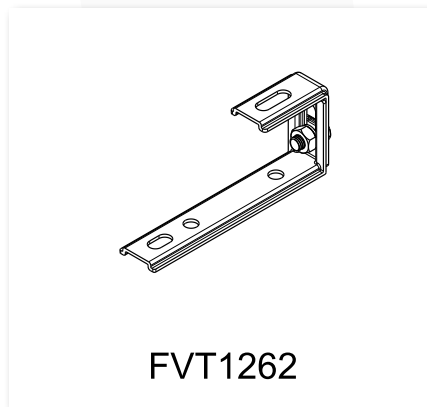
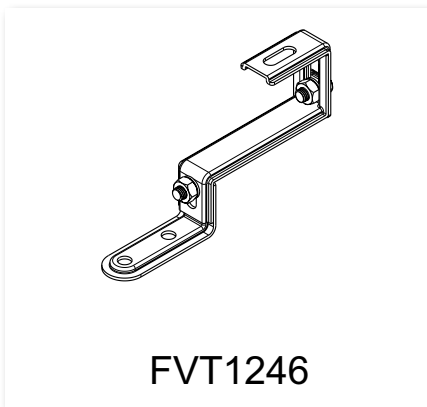
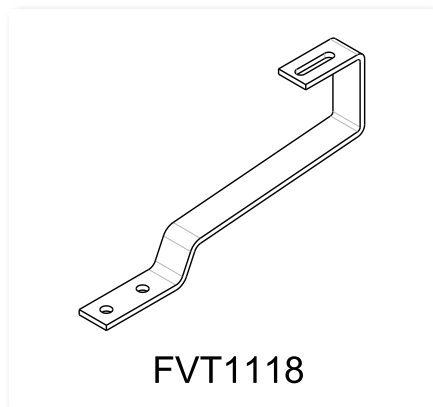

Per staffaggio su legno

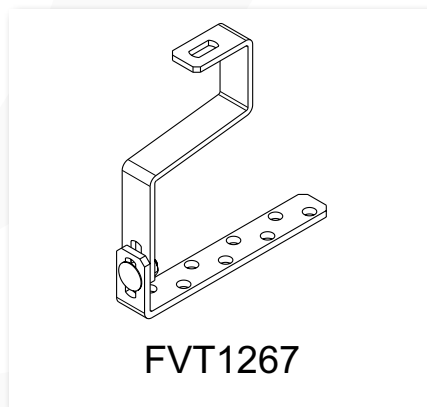
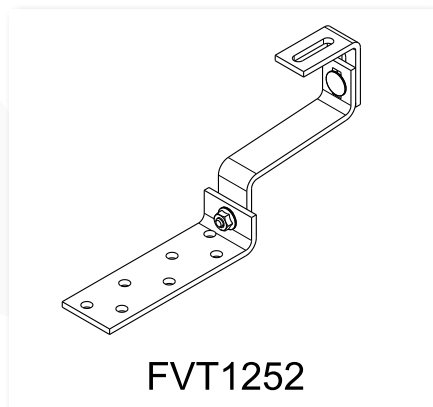



Tetto a falda-recupero amianto. Applicazione con vitoni da legno FVT1315.



Tetto in lamiera grecata. Applicazione con staffe a disegno FVT95XX.



Tetto piano industriale con ghiaia. Applicazione con vasche zavorra FVT1455 e triangoli a 30° FVT1511.



Tetto a falda con tegole. Applicazione con staffa Inox regolabile FVT1256.



Tetto guaina industriale a volta. Applicazione diretta PRF Zincato a Caldo con guarnizione butilica.



Tetto piano industriale con guaina. Applicazione con vasche zavorra FVT1455 e triangoli a 30° FVT1511.



Tetto piano con triangolo singolo verticale zavorrato.



Tetto piano con triangolo quadruplo orizzontale e zavorrato.



Tetto in lamiera grecata e FVT5000.



Tetto piano pannello orizzontale e zavorre flat.



Installazione su tetto e cupolotti e triangolo FVT1511.



Pensilina con pannello triplo orizzontale.



Triangolo triplo orizzontale zavorrato.



Triangolo singolo verticale 30°.



Pannello verticale e zavorre Flat.



Lamiera grecata e FVT5000.



Triangolo doppio orizzontale a 30° zavorrato.



Triangolo singolo verticale a 30° con vasche zavorra.



Triangolo singolo verticale a 30° zavorrato.



Pannello orizzontale e zavorre Flat.



Pannello singolo verticale a 30° con vasche zavorra.



Triangolo doppio orizzontale a 30° e zavorre.



Lamiera grecata e FVT5120.



Pannelli in orizzontale in facciata.

Profili in acciaio zincato a caldo

Materiale: Acciaio FeP02 zincato UNI EN 10111-2008

Peso specifico	78,5	KN/m ³
Modulo di elasticità longitudinale	210000	N/mm ²
Modulo di elasticità tangenziale	79000	N/mm ²
Coeff. dilatazione termica lineare	1,2*10 ⁻⁵	1/°C
Resistenza al limite ultimo fy	-	N/mm ²
Resistenza al limite di snervamento fy	430	N/mm ²
Resistenza al limite elastico f0,2	190	N/mm ²

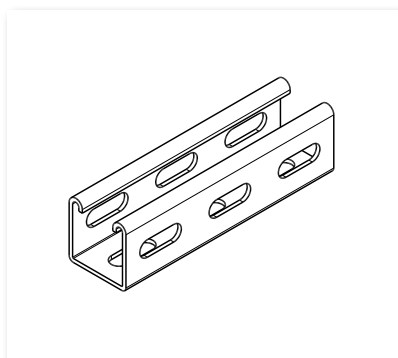

PROFILO 41x41x2,5 mm - Asolato sui tre lati

Caratteristiche meccaniche

Area della sezione	A	249,44	mm ²
Peso al metro lineare	pp	1,96	daN/m
Momento d'inerzia X	Jx	62498,93	mm ⁴
Momento d'inerzia Y	Jy	70043,67	mm ⁴
Momento resistente X	Wx	2892,37	mm ³
Momento resistente Y	Wy	3241,53	mm ³
Raggio d'inerzia X	ix	15,83	mm
Raggio d'inerzia Y	iy	16,76	mm



Tabella dei carichi ammissibili (con Fmax < L/250)

Lunghezza trave L (mm)	Carico unif. Distrib. (daN/m)	Carico concentrato in mezzeria (daN)
500	1758,56	439,64
750	781,58	293,09
1000	403,19	219,82
1250	206,43	161,38
1500	119,46	112,00
1750	75,23	82,28
2000	50,40	63,00

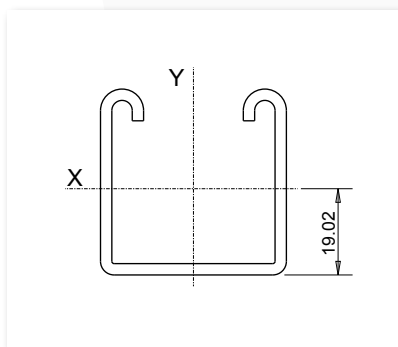
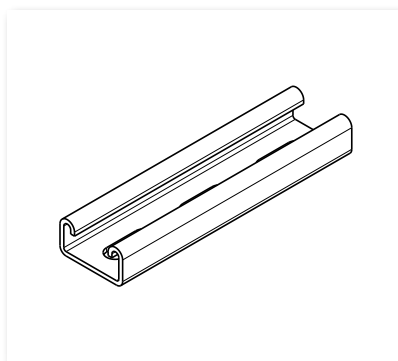

PROFILO 41x21x2,5 mm - Asolato sul fondo

Caratteristiche meccaniche

Area della sezione	A	204,44	mm ²
Peso al metro lineare	pp	1,60	daN/m
Momento d'inerzia X	Jx	11295,41	mm ⁴
Momento d'inerzia Y	Jy	53344,92	mm ⁴
Momento resistente X	Wx	1000,99	mm ³
Momento resistente Y	Wy	2602,19	mm ³
Raggio d'inerzia X	ix	7,43	mm
Raggio d'inerzia Y	iy	16,15	mm



Tabella dei carichi ammissibili (con Fmax < L/250)

Lunghezza trave L (mm)	Carico unif. Distrib. (daN/m)	Carico concentrato in mezzeria (daN)
500	582,95	152,15
750	172,73	80,97
1000	72,87	45,54
1250	37,31	29,15
1500	21,59	20,24
1750	13,60	14,87
2000	9,11	11,39

Profili in acciaio inox

Materiale: Acciaio inox AISI 304 n. 14301 EN 10088-3 2005		
Peso specifico	79,1	KN/m ³
Modulo di elasticità longitudinale	196000	N/mm ²
Modulo di elasticità tangenziale	86000	N/mm ²
Coeff. dilatazione termica lineare	1,65*10 ⁻⁵	1/°C
Resistenza al limite ultimo fy	500	N/mm ²
Resistenza al limite di snervamento fy	430	N/mm ²
Resistenza al limite elastico f _{0,2}	190	N/mm ²

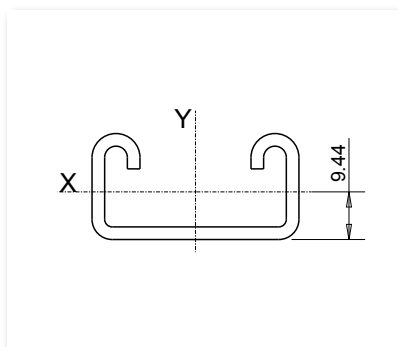
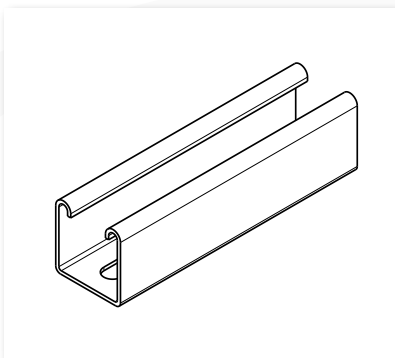

PROFILO 41x41x2 mm - Asolato sul fondo			
Caratteristiche meccaniche			
Area della sezione	A	250,23	mm ²
Peso al metro lineare	pp	1,98	daN/m
Momento d'inerzia X	Jx	52501,29	mm ⁴
Momento d'inerzia Y	Jy	75547,03	mm ⁴
Momento resistente X	Wx	2414,95	mm ³
Momento resistente Y	Wy	3685,22	mm ³
Raggio d'inerzia X	ix	14,48	mm
Raggio d'inerzia Y	iy	17,38	mm



Tabella dei carichi ammissibili (con Fmax < L/250)		
Lunghezza trave L (mm)	Carico unif. Distrib. (daN/m)	Carico concentrato in mezzeria (daN)
500	1468,29	367,07
750	652,57	244,72
1000	316,12	183,54
1250	161,85	126,45
1500	93,66	87,81
1750	58,98	64,51
2000	39,51	49,39



PROFILO 41x21x2 mm - Asolato sui fondo			
Caratteristiche meccaniche			
Area della sezione	A	170,23	mm ²
Peso al metro lineare	pp	1,35	daN/m
Momento d'inerzia X	Jx	9417,69	mm ⁴
Momento d'inerzia Y	Jy	45100,36	mm ⁴
Momento resistente X	Wx	810,52	mm ³
Momento resistente Y	Wy	2200,02	mm ³
Raggio d'inerzia X	ix	7,44	mm
Raggio d'inerzia Y	iy	16,28	mm

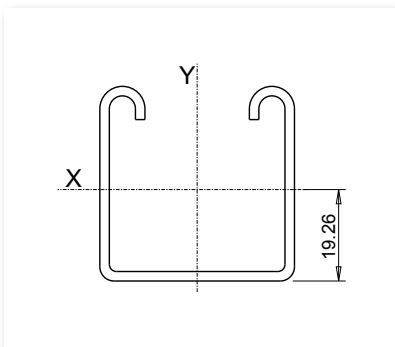
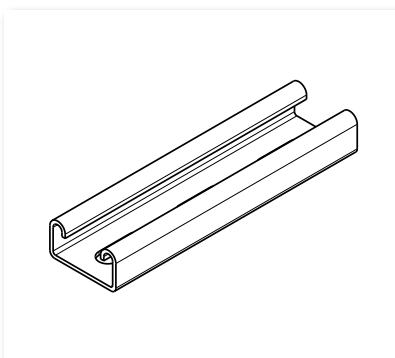

Tabella dei carichi ammissibili (con Fmax < L/250)		
Lunghezza trave L (mm)	Carico unif. Distrib. (daN/m)	Carico concentrato in mezzeria (daN)
500	453,64	123,20
750	134,41	63,01
1000	56,71	35,44
1250	29,03	22,68
1500	16,80	15,75
1750	10,58	11,57
2000	7,09	8,86

Profili in alluminio

Materiale: Alluminio EN AW6060 tempra T6

Peso specifico	27	KN/m ³
Modulo di elasticità longitudinale	69000	N/mm ²
Modulo di elasticità tangenziale	26000	N/mm ²
Coeff. dilatazione termica lineare	2,3*10 ⁻⁵	1/°C
Resistenza al limite ultimo fy	190	N/mm ²
Resistenza al limite di snervamento fy	-	N/mm ²
Resistenza al limite elastico f _{0,2}	150	N/mm ²

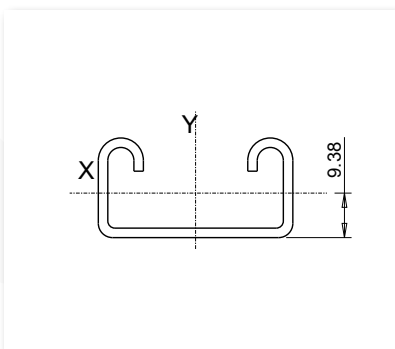
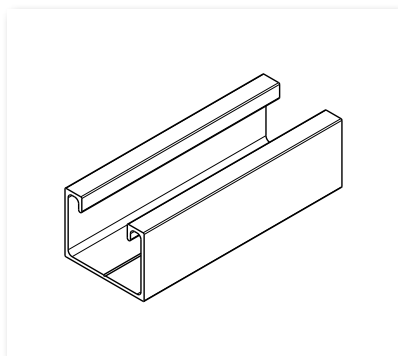

Profilo ribassato FVT1004

Caratteristiche meccaniche

Area della sezione	A	198,27	mm ²
Peso al metro lineare	pp	0,54	daN/m
Momento d'inerzia X	Jx	25762,76	mm ⁴
Momento d'inerzia Y	Jy	50935,04	mm ⁴
Momento resistente X	Wx	1551,55	mm ³
Momento resistente Y	Wy	2546,75	mm ³
Raggio d'inerzia X	ix	11,40	mm
Raggio d'inerzia Y	iy	16,03	mm



Tabella dei carichi ammissibili (con Fmax < L/250)

Lunghezza trave L (mm)	Carico unif. Distrib. (daN/m)	Carico concentrato in mezzeria (daN)
125	-	744,75
200	-	465,47
250	-	372,37
333	-	279,56
400	-	213,32
450	-	168,55
500	-	136,52

Profili in alluminio

Materiale: Alluminio EN AW6060 tempra T6		
Peso specifico	27	KN/m ³
Modulo di elasticità longitudinale	69000	N/mm ²
Modulo di elasticità tangenziale	26000	N/mm ²
Coeff. dilatazione termica lineare	2,3*10 ⁻⁵	1/°C
Resistenza al limite ultimo fy	190	N/mm ²
Resistenza al limite di snervamento fy	-	N/mm ²
Resistenza al limite elastico f _{0,2}	150	N/mm ²

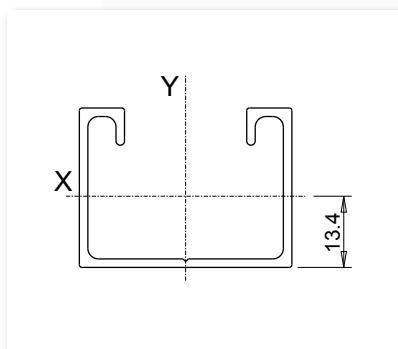
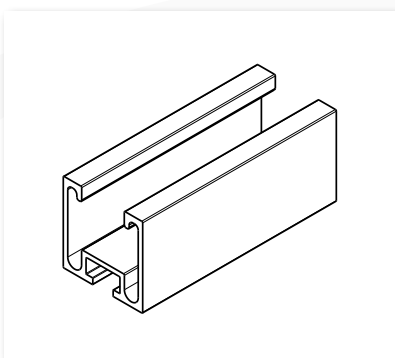

Profilo semplice FVTXXXX Sp. 2,3 mm			
Caratteristiche meccaniche			
Area della sezione	A	418	mm ²
Peso al metro lineare	pp	1,128	daN/m
Momento d'inerzia X	Jx	82844	mm ⁴
Momento d'inerzia Y	Jy	101229	mm ⁴
Momento resistente X	Wx	3531	mm ³
Momento resistente Y	Wy	4938	mm ³
Raggio d'inerzia X	ix	14,08	mm
Raggio d'inerzia Y	iy	15,56	mm



Tabella dei carichi ammissibili (con Fmax < L/250)		
Lunghezza trave L (mm)	Carico unif. Distrib. (daN/m)	Carico concentrato in mezzeria (daN)
500	1300	325
750	410	190
1000	175	109
1250	89	70
1500	52	48
1750	32	35
2000	21	27



Profilo semplice FVT1023 Sp. 1,6 mm			
Caratteristiche meccaniche			
Area della sezione	A	293,4	mm ²
Peso al metro lineare	pp	0,79	daN/m
Momento d'inerzia X	Jx	60429	mm ⁴
Momento d'inerzia Y	Jy	71873	mm ⁴
Momento resistente X	Wx	2542	mm ³
Momento resistente Y	Wy	3506	mm ³
Raggio d'inerzia X	ix	14,4	mm
Raggio d'inerzia Y	iy	15,7	mm

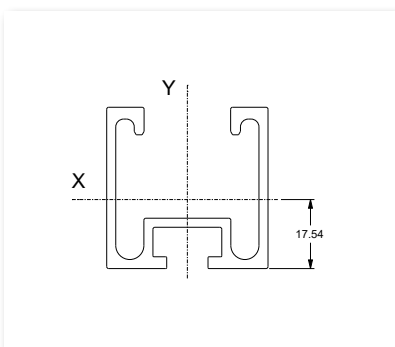
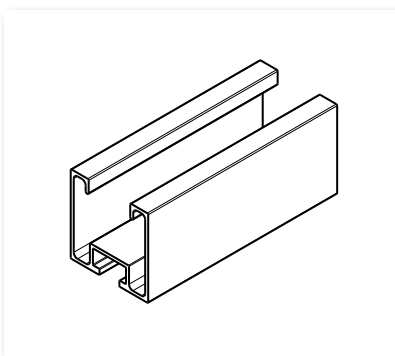

Tabella dei carichi ammissibili (con Fmax < L/250)		
Lunghezza trave L (mm)	Carico unif. Distrib. (daN/m)	Carico concentrato in mezzeria (daN)
500	935	230
750	303	142
1000	128	80
1250	65	51
1500	37	35
1750	23	26
2000	16	20

Profili in alluminio

Materiale: Alluminio EN AW6060 tempra T6		
Peso specifico	27	KN/m ³
Modulo di elasticità longitudinale	69000	N/mm ²
Modulo di elasticità tangenziale	26000	N/mm ²
Coeff. dilatazione termica lineare	2,3*10 ⁻⁵	1/°C
Resistenza al limite ultimo fy	190	N/mm ²
Resistenza al limite di snervamento fy	-	N/mm ²
Resistenza al limite elastico f _{0,2}	150	N/mm ²

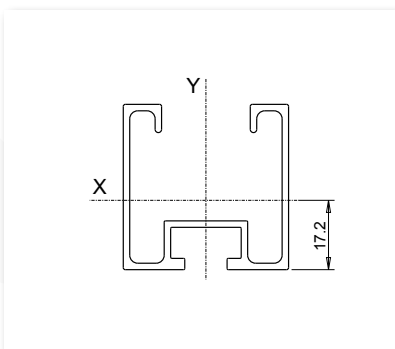
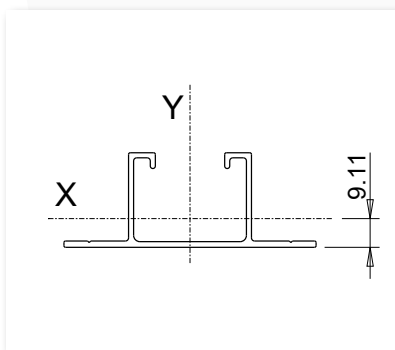
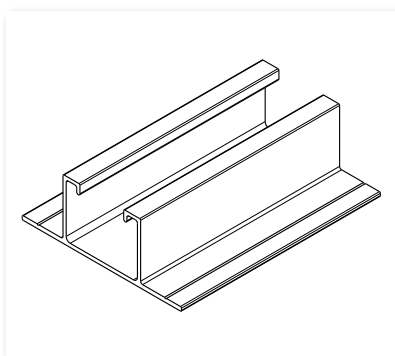

Profilo a base larga FVT1016			
Caratteristiche meccaniche			
Area della sezione	A	276,92	mm ²
Peso al metro lineare	pp	0,76	daN/m
Momento d'inerzia X	Jx	32743,51	mm ⁴
Momento d'inerzia Y	Jy	122046,31	mm ⁴
Momento resistente X	Wx	1567,44	mm ³
Momento resistente Y	Wy	3051,16	mm ³
Raggio d'inerzia X	ix	10,87	mm
Raggio d'inerzia Y	iy	20,99	mm

Tabella dei carichi ammissibili (con Fmax < L/250)		
Lunghezza trave L (mm)	Carico unif. Distrib. (daN/m)	Carico concentrato in mezzzeria (daN)
125	-	616,91
200	-	385,57
250	-	308,45
333	-	231,57
400	-	165,18
450	-	130,51
500	-	105,72

Profili in alluminio

Materiale: Alluminio EN AW6060 tempra T6		
Peso specifico	27	KN/m ³
Modulo di elasticità longitudinale	69000	N/mm ²
Modulo di elasticità tangenziale	26000	N/mm ²
Coeff. dilatazione termica lineare	2,3*10 ⁻⁵	1/°C
Resistenza al limite ultimo fy	190	N/mm ²
Resistenza al limite di snervamento fy	-	N/mm ²
Resistenza al limite elastico f _{0,2}	150	N/mm ²

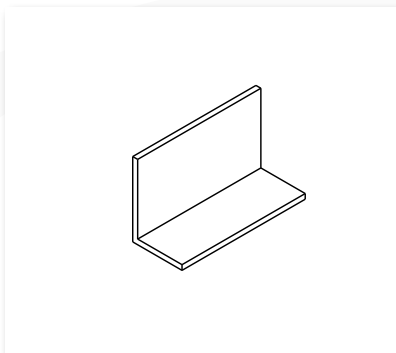

Angolare 60x40x4 FVT 1011			
Caratteristiche meccaniche			
Area della sezione	A	384	mm ²
Peso al metro lineare	pp	1,04	daN/m
Momento d'inerzia X	Jx	142752	mm ⁴
Momento d'inerzia Y	Jy	51872	mm ⁴
Momento resistente X	Wx	3524,74	mm ³
Momento resistente Y	Wy	1280,79	mm ³
Raggio d'inerzia X	ix	19,28	mm
Raggio d'inerzia Y	iy	11,62	mm

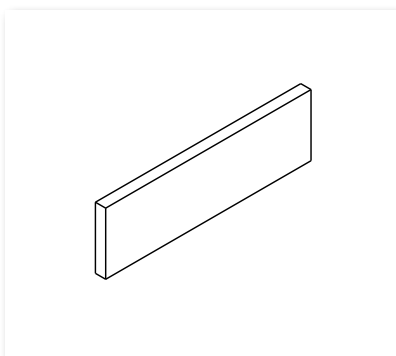
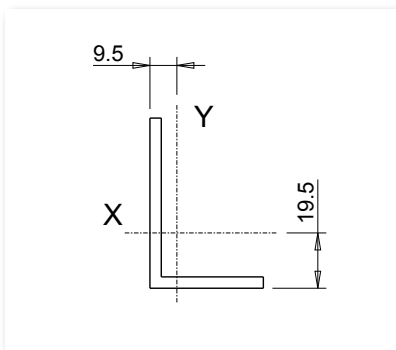

Piatto 30x5 - Caratteristiche meccaniche			
Area della sezione	A	150	mm ²
Peso al metro lineare	pp	0,41	daN/m
Momento d'inerzia X	Jx	11250	mm ⁴
Momento d'inerzia Y	Jy	312,50	mm ⁴
Momento resistente X	Wx	750	mm ³
Momento resistente Y	Wy	20,83	mm ³
Raggio d'inerzia X	ix	8,66	mm
Raggio d'inerzia Y	iy	1,44	mm

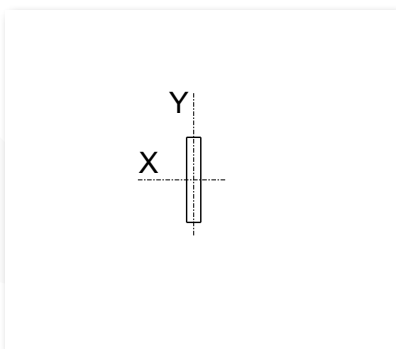

PREMESSA GENERALE

Gli impianti fotovoltaici sono per loro stessa natura esposti alle condizioni atmosferiche, in particolar modo all'azione del vento e della neve. La conformazione del territorio, l'altitudine, la vicinanza al mare e l'altezza dal suolo sono le principali variabili che definiscono le condizioni di lavoro a cui sarà sottoposto l'impianto fotovoltaico per tutti gli anni della sua operatività.

Particolarmente esposti all'azione del vento risultano essere gli impianti con i pannelli fotovoltaici montati su supporti triangolari ai quali si dovrà riservare una particolare attenzione in fase di progetto.

Il corretto dimensionamento dell'impianto è di fondamentale importanza per ottenere la massima resa in termini di energia elettrica prodotta nella più completa sicurezza.

Una struttura sottodimensionata sarebbe a rischio di cedimento con rischi potenzialmente gravi sia per l'impianto stesso sia verso terzi. Una struttura sovradimensionata si tradurrebbe in costi non giustificati da dover ammortizzare.

Appoggiandosi ad un primario studio di Ingegneria e supportata da prodotti e soluzioni di eccellenza, Teknomega è in grado di offrire un servizio completo per la quasi totalità delle differenti soluzioni di impiantistica nel fotovoltaico. Tutto questo nel pieno rispetto delle normative tecniche e paesaggistiche in essere.

La descrizione riportata di seguito ha valore puramente esplicativo delle norme e delle regole da seguire per una corretta definizione di una struttura di supporto per pannelli fotovoltaici.

Quanto riportato in questo catalogo non è da ritenersi una dichiarazione di conformità e non può in nessun modo sostituire la certificazione dell'impianto.

Norme di riferimento

D.M. 17 Gennaio 2018 - "Norme Tecniche per le costruzioni"

Circolare 21 gennaio 2019, n. 7 C.S.LL.PP.

Eurocodice 3 - Progettazione strutture in acciaio.

Eurocodice 9 - Progettazione strutture in alluminio.

Caratteristiche fisiche dei materiali

Profili in alluminio

Materiale: EN AW 6060 T6

Peso Specifico: 27 KN/m³

Modulo di elasticità longitudinale E: 69000 N/mm²

Modulo di elasticità tangenziale G: 26000 N/mm²

Coefficiente di dilatazione termica: 2,3x10⁻⁵ 1/°C

Resistenza al limite ultimo fy: 190 N/mm²

Resistenza al limite elastico FO.2: 150 N/mm²

Profili in acciaio

Materiale: EN 10111:2008

Peso Specifico: 78,5 KN/m³

Modulo di elasticità longitudinale E: 210000 N/mm²

Modulo di elasticità tangenziale G: 79000 N/mm²

Coefficiente di dilatazione termica: 1,2x10⁻⁵ 1/°C

Resistenza al limite di snervamento fy: 430 N/mm²

Resistenza al limite elastico FO.2: 190 N/mm²

Metodo di calcolo

Per il calcolo delle strutture si segue il metodo degli stati limite ultimi per l'analisi della resistenza dei profili e il metodo degli stati limite di esercizio per le verifiche delle deformazioni elastiche della struttura.

Le formule utilizzate sono le seguenti:

Stati Limite Ultimi (S.L.U.)

$$F_d = \gamma_g G_k + \gamma_q \bullet | Q_{1k} + \sum_{i=2}^{i=n} (\Psi_{0i} Q_{ik}) |$$

Stati Limite d'Esercizio (S.L.E.)

$$F_d = G_k + Q_{1k} + \sum_{i=2}^{i=n} (\Psi_{0i} Q_{ik})$$

Dove:

G_k Rappresenta il valore dei carichi permanenti: tipicamente il peso della struttura.

Q_{1k} Rappresenta il valore caratteristico in ogni combinazione dell'azione di base.

Q_{ik} Rappresenta i valori caratteristici delle azioni variabili tra loro indipendenti

Per quanto riguarda le azioni variabili sono stati considerati i carichi esercitati sulla struttura dall'azione del vento e della neve.

La parte seguente è stata estratta dalle norme contenute nel

D.M. 17 Gennaio 2018 - "Norme Tecniche per le costruzioni" e la Circolare 21 gennaio 2019, n. 7 C.S.LL.PP.

3.3.1 Generalità

Il vento, la cui direzione si considera generalmente orizzontale, esercita sulle costruzioni azioni che variano nel tempo e nello spazio provocando, in generale, effetti dinamici.

Per le costruzioni usuali tali azioni sono convenzionalmente ricondotte alle azioni statiche equivalenti definite al § 3.3.3. Peraltro, per le costruzioni di forma o tipologia inusuale, oppure di grande altezza o lunghezza, o di rilevante snellezza e leggerezza, o di notevole flessibilità e ridotte capacità dissipative, il vento può dare luogo ad effetti la cui valutazione richiede l'uso di metodologie di calcolo e sperimentali adeguate allo stato dell'arte e che tengano conto della dinamica del sistema.

3.3.2 Velocità di riferimento

La velocità di riferimento v_r è il valore caratteristico della velocità del vento a 10 m dal suolo su un terreno di categoria di esposizione II (vedi Tab. 3.3.II), mediata su 10 minuti e riferita al periodo di ritorno di progetto TR. Tale velocità è definita dalla relazione:

$$v_r = v_b \cdot c_r \quad (3.3.2)$$

dove:

v_b è la velocità base di riferimento, di cui al § 3.3.1;

c_r è il coefficiente di ritorno, funzione del periodo di ritorno di progetto TR.

Ove non specificato diversamente, si assumerà TR = 50 anni, cui corrisponde $c_r = 1$.

$$v_b = v_{b,0} \cdot c_a \quad (3.3.1)$$

$v_{b,0}$ è la velocità base di riferimento al livello del mare, assegnata nella Tab. 3.3.I in funzione della zona in cui sorge la costruzione (Fig. 3.3.1);

c_a è il coefficiente di altitudine fornito dalla relazione:

$$c_a = 1 \quad \text{per } a_s \leq a_0$$

$$c_a = 1 + k_s \left(\frac{a_s}{a_0} - 1 \right) \quad \text{per } a_0 < a_s \leq 1500 \text{ m} \quad (3.3.1.b)$$

dove:

a_0, k_s sono parametri forniti nella Tab. 3.3.I in funzione della zona in cui sorge la costruzione (Fig. 3.3.1);

a_s è l'altitudine sul livello del mare del sito ove sorge la costruzione.

Tale zonazione non tiene conto di aspetti specifici e locali che, se necessario, dovranno essere definiti singolarmente.

Tabella 3.3.I - Valori dei parametri $v_{b,0}$, a_0 , k_s

Zona	Descrizione	$v_{b,0}$ [m/s]	a_0 [m]	k_s
1	Valle d'Aosta, Piemonte, Lombardia, Trentino Alto Adige, Veneto, Friuli Venezia Giulia (con l'eccezione della provincia di Trieste)	25	1000	0,40
2	Emilia Romagna	25	750	0,45
3	Toscana, Marche, Umbria, Lazio, Abruzzo, Molise, Puglia, Campania, Basilicata, Calabria (esclusa la provincia di Reggio Calabria)	27	500	0,37
4	Sicilia e provincia di Reggio Calabria	28	500	0,36
5	Sardegna (zona a oriente della retta congiungente Capo Teulada con l'Isola di Maddalena)	28	750	0,40
6	Sardegna (zona a occidente della retta congiungente Capo Teulada con l'Isola di Maddalena)	28	500	0,36
7	Liguria	28	1000	0,54
8	Provincia di Trieste	30	1500	0,50
9	Isole (con l'eccezione di Sicilia e Sardegna) e mare aperto	31	500	0,32

Per altitudini superiori a 1500 m sul livello del mare si potrà fare riferimento alle condizioni locali di clima e di esposizione. I valori della velocità di riferimento possono essere ricavati da datisupportati da opportuna documentazione o da indagini statistiche adeguatamente comprovate. Fatte salve tali valutazioni, comunque raccomandate in prossimità di vette e crinali, i valori utilizzati non dovranno essere minori di quelli previsti per 1500 m di altitudine.

3.3.3 Azioni statiche equivalenti

Le azioni statiche del vento sono costituite da pressioni e depressioni agenti normalmente alle superfici, sia esterne che interne, degli elementi che compongono la costruzione. L'azione del vento sul singolo elemento viene determinata considerando la combinazione più gravosa della pressione agente sulla superficie esterna e della pressione agente sulla superficie interna dell'elemento. Nel caso di costruzioni o elementi di grande estensione, si deve inoltre tenere conto delle azioni tangenti esercitate dal vento. L'azione d'insieme esercitata dal vento su una costruzione è data dalla risultante delle azioni su singoli elementi, considerando come direzione del vento, quella corrispondente ad uno degli assi principali della pianta della costruzione; in casi particolari, come ad esempio per le torri a base quadrata o rettangolare, si deve considerare anche l'ipotesi di vento spirante secondo la direzione di una delle diagonali.

Figura 3.3.1
Mappa delle zone in cui è suddiviso il territorio italiano

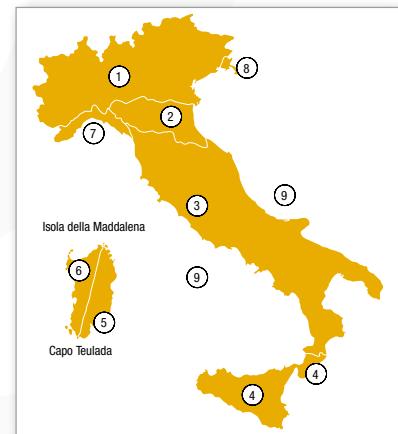

3.3.4 Pressione del vento

La pressione del vento è data dall'espressione:

$$p = q_r c_e c_p c_d \quad (3.3.2)$$

dove:

q_r è la pressione cinetica di riferimento di cui al § 3.3.6;

c_e è il coefficiente di esposizione di cui al § 3.3.7;

c_p è il coefficiente di forma (o coefficiente aerodinamico), funzione della tipologia e della geometria della costruzione e del suo orientamento rispetto alla direzione del vento. Il suo valore può essere ricavato da dati suffragati da opportuna documentazione o da prove sperimentali in galleria del vento;

c_d è il coefficiente dinamico con cui si tiene conto degli effetti riduttivi associati alla non contemporaneità delle massime pressioni locali e degli effetti amplificativi dovuti alle vibrazioni strutturali. Indicazioni per la sua valutazione sono riportate al § 3.3.9.

3.3.5 Azione tangenziale del vento

L'azione tangente per unità di superficie parallela alla direzione del vento è data dall'espressione: $p_f = q_r c_e c_f$ (3.3.3)

dove:

q_r, c_e sono definiti ai §§ 3.3.6 e 3.3.7;

c_f è il coefficiente d'attrito, funzione della scabrezza della superficie sulla quale il vento esercita l'azione tangente. Il suo valore può essere ricavato da dati suffragati da opportuna documentazione o da prove sperimentali in galleria del vento.

3.3.6 Pressione cinetica di riferimento

La pressione cinetica di riferimento q_b (in N/m^2) è data dall'espressione: $q_r = \frac{1}{2} \rho v_r^2$ (3.3.4)

dove:

v_r è la velocità di riferimento del vento (in m/s);

ρ è la densità dell'aria assunta convenzionalmente costante e pari a $1,25 \text{ kg/m}^3$.

3.3.7 Coefficiente di esposizione

Il coefficiente di esposizione c_e dipende dall'altezza z sul suolo del punto considerato, dalla topografia del terreno, e dalla categoria di esposizione del sito ove sorge la costruzione. In assenza di analisi specifiche che tengano in conto la direzione di provenienza del vento e l'effettiva scabrezza e topografia del terreno che circonda la costruzione, per altezze sul suolo non maggiori di $z = 200 \text{ m}$, esso è dato dalla formula:

$$\begin{aligned} c_e(z) &= k_r 2 c_t \ln(z/z_0) [7 + c_t \ln(z/z_0)] && \text{per } z \geq z_{\min} \\ c_e(z) &= c_e(z_{\min}) && \text{per } z < z_{\min} \end{aligned} \quad (3.3.5)$$

dove:

k_r, z_0, z_{\min} sono assegnati in Tab. 3.3.II in funzione della categoria di esposizione del sito ove sorge la costruzione;

c_t è il coefficiente di topografia.

Tabella 3.3.II - Parametri per la definizione del coefficiente di esposizione

Categoria di esposizione del sito	k_r	z_0 [m]	z_{\min} [m]
I	0,17	0,01	2
II	0,19	0,05	4
III	0,20	0,10	5
IV	0,22	0,30	8
V	0,23	0,70	12

In mancanza di analisi specifiche, la categoria di esposizione è assegnata nella Fig. 3.3.2 in funzione della posizione geografica del sito ove sorge la costruzione e della classe di rugosità del terreno definita in Tab. 3.3.III.

Nelle fasce entro i 40 km dalla costa delle zone 1, 2, 3, 4, 5 e 6, la categoria di esposizione è indipendente dall'altitudine del sito.

Il coefficiente di topografia c_t è posto generalmente pari a 1, sia per le zone pianeggianti sia per quelle ondulate, collinose e montane. In questo caso, la Fig. 3.3.3 riporta le leggi di variazione di c_e per le diverse categorie di esposizione.

Nel caso di costruzioni ubicate presso la sommità di colline o pendii isolati il coefficiente di topografia c_t può essere valutato dal progettista con analisi più approfondite.

Tabella 3.3.III - Classi di rugosità del terreno

Classe di rugosità del terreno	Descrizione
A	Aree urbane in cui almeno il 15% della superficie sia coperto da edifici la cui altezza media superi i 15 m
B	Aree urbane (non di classe A), suburbane, industriali e boschive
C	Aree con ostacoli diffusi (alberi, case, muri, recinzioni,...); aree con rugosità non riconducibile alle classi A, B, D
D	Aree prive di ostacoli (aperta campagna, aeroporti, aree agricole, pascoli, zone paludose o sabbiose, superfici innevate o ghiacciate, mare, laghi,...)

L'assegnazione della classe di rugosità non dipende dalla conformazione orografica e topografica del terreno. Affinché una costruzione possa dirsi ubicata in classe A o B è necessario che la situazione che contraddistingue la classe permanga intorno alla costruzione per non meno di 1 km e comunque non meno di 20 volte l'altezza della costruzione. Laddove sussistano dubbi sulla scelta della classe di rugosità, a meno di analisi dettagliate, verrà assegnata la classe più sfavorevole.

Figura 3.3.2 - Definizione delle categorie di esposizione



Figura 3.3.3 - Andamento del coefficiente di esposizione c_e con la quota (per $c_t = 1$)



3.3.8 Coefficiente dinamico

Il coefficiente dinamico tiene in conto degli effetti riduttivi associati alla non contemporaneità delle massime pressioni locali e degli effetti amplificativi dovuti alla risposta dinamica della struttura. Esso può essere assunto cautelativamente pari ad 1 nelle costruzioni di tipologia ricorrente, quali gli edifici di forma regolare non eccedenti 80 m di altezza ed i capannoni industriali, oppure può essere determinato mediante analisi specifiche o facendo riferimento a dati di comprovata affidabilità.

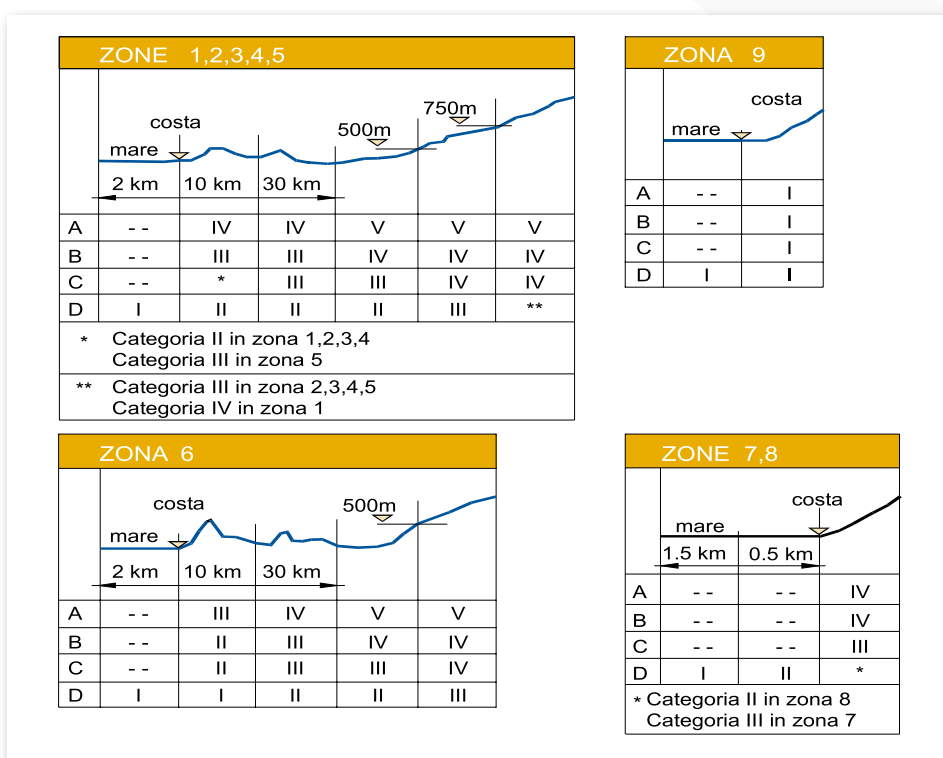
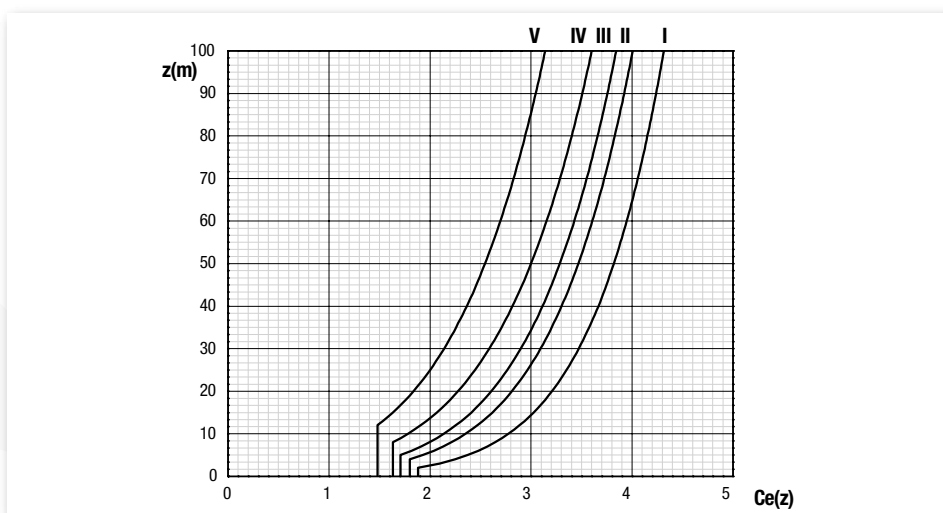
3.3.9 Coefficiente di forma o coefficiente aerodinamico

In assenza di valutazioni più precise, suffragate da opportuna documentazione o prove sperimentali in galleria del vento, per i coefficienti di pressione si assumono i valori riportati nei paragrafi C3.3.8 della Circolare 21 gennaio 2019 n.7 C.S.LL.PP..

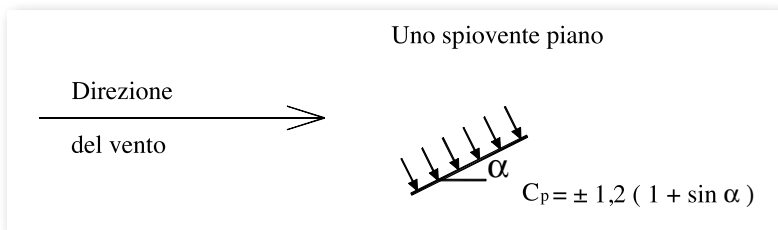

3.4 AZIONI DELLA NEVE

3.4.1 Carico neve

Il carico provocato dalla neve sulle coperture sarà valutato mediante la seguente espressione:

$$q_s = \mu_i q_{sk} C_E C_t \quad (3.3.7)$$

dove:

q_s è il carico neve sulla copertura;

μ_i è il coefficiente di forma della copertura, fornito al successivo § 3.4.3;

q_{sk} è il valore caratteristico di riferimento del carico neve al suolo [kN/m^2], fornito al successivo § 3.4.2 per un periodo di ritorno di 50 anni;

C_E è il coefficiente di esposizione di cui al § 3.4.4;

C_t è il coefficiente termico di cui al § 3.4.5.

Si ipotizza che il carico agisca in direzione verticale e lo si riferisce alla proiezione orizzontale della superficie della copertura.

3.4.2 Valore caratteristico del carico neve al suolo

Il carico neve al suolo dipende dalle condizioni locali di clima e di esposizione, considerata la variabilità delle precipitazioni nevose da zona a zona. In mancanza di adeguate indagini statistiche e specifici studi locali, che tengano conto sia dell'altezza del manto nevoso che della sua densità, il carico di riferimento neve al suolo, per località poste a quota inferiore a 1500 m sul livello del mare, non dovrà essere assunto minore di quello calcolato in base alle espressioni riportate nel seguito, cui corrispondono valori associati ad un periodo di ritorno pari a 50 anni (vedi Fig. 3.4.1). Va richiamato il fatto che tale zonazione non può tenere conto di aspetti specifici e locali che, se necessario, dovranno essere definiti singolarmente. L'altitudine di riferimento a_s è la quota del suolo sul livello del mare nel sito di realizzazione dell'edificio. Per altitudini superiori a 1500 m sul livello del mare si dovrà fare riferimento alle condizioni locali di clima e di esposizione utilizzando comunque valori di carico neve non inferiori a quelli previsti per 1500 m. I valori caratteristici minimi del carico della neve al suolo sono quelli riportati nel seguito.

Figura 3.4.1 - Zone di carico neve

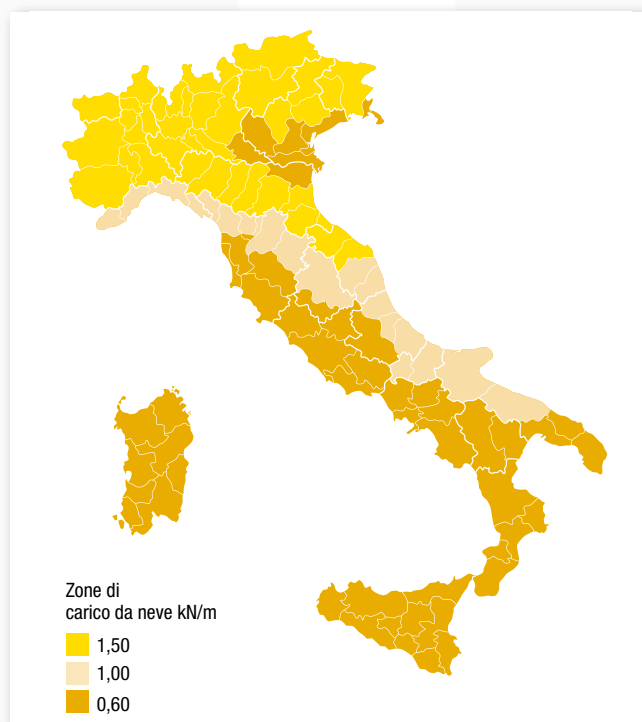

Zona I - Alpina - Aosta, Belluno, Bergamo, Biella, Bolzano, Brescia, Como, Cuneo, Lecco, Pordenone, Sondrio, Torino, Trento, Udine, Verbania, Verbano-Cusio-Ossola, Vercelli, Vicenza:

$$\begin{aligned} q_{sk} &= 1,50 \text{ kN/m}^2 \text{ as} \leq 200 \text{ m} \\ q_{sk} &= 1,39 [1 + (as/728)^2] \text{ kN/m}^2 \text{ as} > 200 \text{ m} \quad (3.3.8) \end{aligned}$$

Zona I - Mediterranea - Alessandria, Ancona, Asti, Bologna, Cremona, Forlì-Cesena, Lodi, Milano, Modena, Monza Brianza, Novara, Parma, Pavia, Pesaro e Urbino, Piacenza, Ravenna, Reggio Emilia, Rimini, Treviso, Varese:

$$\begin{aligned} q_{sk} &= 1,50 \text{ kN/m}^2 \text{ as} \leq 200 \text{ m} \\ q_{sk} &= 1,35 [1 + (as/602)^2] \text{ kN/m}^2 \text{ as} > 200 \text{ m} \quad (3.3.9) \end{aligned}$$

Zona II - Arezzo, Ascoli Piceno, Avellino, Bari, Barletta-Andria-Trani, Benevento, Campobasso, Chieti, Fermo, Ferrara, Firenze, Foggia, Frosinone, Genova, Gorizia, Imperia, Isernia, L'Aquila, La Spezia, Lucca, Macerata, Mantova, Massa Carrara, Padova, Perugia, Pescara, Pistoia, Prato, Rieti, Rovigo, Savona, Teramo, Trieste, Venezia, Verona:

$$\begin{aligned} q_{sk} &= 1,00 \text{ kN/m}^2 \text{ as} \leq 200 \text{ m} \\ q_{sk} &= 0,85 [1 + (as/481)^2] \text{ kN/m}^2 \text{ as} > 200 \text{ m} \quad (3.3.10) \end{aligned}$$

Zona III - Agrigento, Brindisi, Cagliari, Caltanissetta, Carbonia-Iglesias, Caserta, Catania, Catanzaro, Cosenza, Crotone, Enna, Grosseto, Latina, Lecce, Livorno, Matera, Medio Campidano, Messina, Napoli, Nuoro, Ogliastra, Olbia Tempio, Oristano, Palermo, Pisa, Potenza, Ragusa, Reggio Calabria, Roma, Salerno, Sassari, Siena, Siracusa, Taranto, Terni, Trapani, Vibo Valentia, Viterbo:

$$\begin{aligned} q_{sk} &= 0,60 \text{ kN/m}^2 \text{ as} \leq 200 \text{ m} \\ q_{sk} &= 0,51 [1 + (as/481)^2] \text{ kN/m}^2 \text{ as} > 200 \text{ m} \quad (3.3.11) \end{aligned}$$

3.4.3 Coefficiente di esposizione

Il coefficiente di esposizione C_E può essere utilizzato per modificare il valore del carico neve in copertura in funzione delle caratteristiche specifiche dell'area in cui sorge l'opera. Valori consigliati del coefficiente di esposizione per diverse classi di topografia sono forniti in Tab. 3.4.I. Se non diversamente indicato, si assumerà $C_E = 1$.

Tabella 3.4.I - Valori di C_E per diverse classi di topografia

Topografia	Descrizione	C_E
Battuta dai venti	Aree pianeggianti non ostruite esposte su tutti i lati, senza costruzioni o alberi più alti.	0,9
Normale	Aree in cui non è presente una significativa rimozione di neve sulla costruzione prodotta dal vento, a causa del terreno, altre costruzioni o alberi.	1,0
Riparata	Aree in cui la costruzione considerata è sensibilmente più bassa del circostante terreno o circondata da costruzioni o alberi più alti	1,1

3.4.4 Coefficiente termico

Il coefficiente termico può essere utilizzato per tener conto della riduzione del carico neve a causa dello scioglimento della stessa, causata dalla perdita di calore della costruzione. Tale coefficiente tiene conto delle proprietà di isolamento termico del materiale utilizzato in copertura. In assenza di uno specifico e documentato studio, deve essere utilizzato $C_t = 1$.

3.4.5 Carico neve sulle coperture

Devono essere considerate le due seguenti principali disposizioni di carico:

- carico da neve depositata in assenza di vento;
- carico da neve depositata in presenza di vento.

3.4.5.1 Coefficiente di forma per le coperture

In generale verranno usati i coefficienti di forma per il carico neve contenuti nel presente paragrafo, dove vengono indicati i relativi valori nominali essendo α , espresso in gradi sessagesimali, l'angolo formato dalla falda con l'orizzontale. I valori del coefficiente di forma μ_1 , riportati in Tab. 3.4.II si riferiscono alle coperture ad una o due falde.

Tabella 3.4.II - Valori del coefficiente di forma

Coefficiente di forma	$0^\circ \leq \alpha \leq 30^\circ$	$30^\circ < \alpha < 60^\circ$	$\alpha \geq 60^\circ$
μ_1	0,8	$0,8 \times \frac{(60-\alpha)}{30}$	0,0

Per coperture a più falde, per coperture con forme diverse, così come per coperture contigue a edifici più alti o per accumulo di neve contro parapetti o più in generale per altre situazioni ritenute significative dal progettista si deve fare riferimento a normative di comprovata validità.

3.4.5.2 Copertura ad una falda

Si assume che la neve non sia impedita di scivolare. Se l'estremità più bassa della falda termina con un parapetto, una barriera od altre ostruzioni, allora il coefficiente di forma non potrà essere assunto inferiore a 0,8 indipendentemente dall'angolo. Si deve considerare la condizione riportata in Fig. 3.4.2, la quale deve essere utilizzata per entrambi i casi di carico con o senza vento.

Figura 3.4.2 - Condizioni di carico per coperture ad una falda

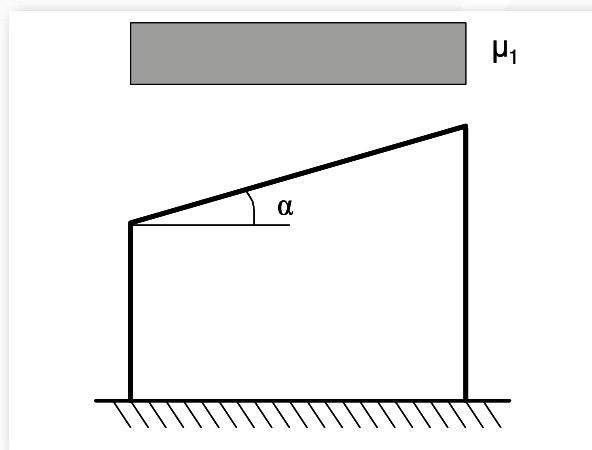

ANALISI DEI RISULTATI

Dopo aver analizzato e definito i carichi che agiscono sulla struttura, si procede con la scelta dei profili da utilizzare, degli interassi da rispettare tra gli appoggi e nel caso di utilizzo di zavorre, con la verifica del peso necessario per ancorare a terra la struttura.

Nella pagina seguente un esempio di certificazione di un impianto.



STRUTTURA ZAVORRATA A SOSTEGNO DI PANNELLI FOTOVOLTAICI

CENTRO COMMERCIALE LANDO -- VIA PEDAGNI 50 - 35030 - VEGGIANO (PD)

Il sottoscritto Massimiliano Colletta con studio in Lodi (LO), via Secondo Cremonesi 4, iscritto all'Ordine degli Ingegneri della Provincia di Lodi al n. 455, abilitato a norma di legge all'esercizio della professione

DICHIARA

che la struttura zavorrata a sostegno di pannelli fotovoltaici installata sulla copertura del CENTRO COMMERCIALE LANDO sito in via Pedagni 50 a Veggiano (PD) è stata calcolata in base al Decreto Ministeriale 17 gennaio 2018 – *Norme Tecniche per le Costruzioni* e alla Circolare del Ministero delle Infrastrutture e dei trasporti n. 7 del 21 gennaio 2019 – *Istruzioni per l'applicazione dell'«Aggiornamento delle «Norme tecniche per le costruzioni» di cui al decreto ministeriale 17 gennaio 2018»*.

I pannelli monocristallini Peimar di dimensioni 992x1.640 mm sono disposti verticalmente ad interasse di 1.017 mm e sono ancorati alle zavorre in calcestruzzo mediante ganasce in alluminio a "Z" (FVT3041) e "Ω" (FVT3112). Il fissaggio sulla copertura piana è realizzato mediante zavorre in calcestruzzo da 30 kg (FVT9099).

Le ipotesi di carico assunte sono le seguenti:

- *Carichi permanenti:*
 - o Zavorre in cls $q_{ZAVORRA} = 30 \text{ kg}$
 - o Pannello fotovoltaico $q_{FOTOVOLTAICO} = 11,06 \text{ kg/m}^2$
- *Azione della neve:*
 - o Carico di neve in zona II con altitudine inferiore a 200 m pari a 100 kg/m² (Tr pari a 50 anni) - coefficiente di forma pari a 0,8 - coefficiente di esposizione e termico pari a 1,0 - si ottiene un sovraccarico di 80 kg/m².
- *Azione del vento:*
 - o Per la valutazione dell'azione del vento si fa riferimento al D.M. 17.01.2018 e alla circolare n. 7 C.S.LL.PP. del 21.01.2019. In particolare la struttura in esame viene considerata appartenente alla zona 1, caratterizzata da una classe di rugosità del terreno D, alla quale corrisponde una categoria di esposizione II. Assumendo una pressione cinetica di riferimento $q_b = 39 \text{ kg/m}^2$, un coefficiente di esposizione $C_e = 2,17$ ($z = 7,5 \text{ m}$), un coefficiente di forza $C_p = -0,28$ e un coefficiente dinamico C_d unitario, si ricava una pressione del vento di 24 kg/m².
- *Azione del sisma:*
 - o Considerando le grandezze in gioco, è di entità modesta rispetto ai carichi accidentali e quindi non preponderante per la verifica del sistema di zavorratura. La resistenza complessiva alle azioni del sisma non è infatti attribuibile alla struttura di zavorratura dell'impianto fotovoltaico in esame ma bensì alla struttura esistente.

Per ulteriori dettagli si rimanda alla relazione di calcolo avente codice PR19_354-RE-01.0.

Si precisa solamente che sarà cura della committenza garantire che la struttura portante della copertura sia in grado di assorbire il sovraccarico indotto dall'impianto fotovoltaico di cui sopra.

Pertanto, stante le precedenti condizioni di carico, il sottoscritto:

CERTIFICA

che la struttura è idonea ad assorbire i carichi massimi di cui sopra in totale sicurezza ed in rispetto delle normative strutturali vigenti.

In fede
29/10/2019

Ing. Massimiliano Colletta



STUDIO TECNICO DI INGEGNERIA 2masteam
Ing. Massimiliano Colletta – Ing. Marco Falocchi
Via Secondo Cremonesi, 4 – 26900 Lodi (LO)
Tel/Fax 0371 842003 – P.IVA 08158590961
info@2masteam.it – www.2masteam.it

NOTE TECNICHE PER LA ZINCATURA A CALDO

La zincatura a caldo è uno dei metodi migliori per la protezione dei manufatti in acciaio.

Con la zincatura a caldo si realizza sia una protezione con effetto barriera sia una protezione galvanica.

La corrosione nel tempo dello stato protettivo di zinco è influenzata principalmente dalla durata dell'esposizione all'umidità e dalla contaminazione superficiale.

I prodotti realizzati con finitura superficiale zincata a caldo, sono realizzati in osservanza dei requisiti tecnici e delle norme internazionali seguenti:

UNI EN ISO 1461: Zincatura a Caldo – specifiche e metodi di prova.

UNI EN ISO 14713: Zincatura a Caldo – linee guida.

Le tabelle seguenti, estratte dalla norma UNI EN ISO 1461 rappresentano gli spessori minimi ottenibili e la durata tipica per i manufatti in acciaio protetti dal trattamento di zincatura a caldo.

Articolo e suo spessore	Spessore medio del rivestimento (minimo) [μm]
Acciaio ≥ 6 mm	85
Acciaio ≥ 3 mm fino a < 6 mm	70
Acciaio $\geq 1,5$ mm fino a < 3 mm	55
Acciaio $< 1,5$ mm	45

Codice	Classe di corrosività	Perdita spessore di zinco [$\mu\text{m}/\text{anno}$]
C1	ambiente interno asciutto	$\leq 0,1$
C2	area rurale esposta nell'entroterra	da 0,1 a 0,7
C3	area entroterra urbana	da 0,7 a 2
C4	area industriale o costiera urbana	da 2 a 4
C5	area industriale con alta umidità o area costiera fronte mare/offshore	da 4 a 8

Codice	Riferimento	Pagina
BFA		
BFA1000	BFA1-M6	61
BFA1005	BFA3-M6	61
BFA1010	BFA1-M8	61
BFA1015	BFA3-M8	61
BFA1020	BFA1-M10	61
BFA1025	BFA3-M10	61
BFA1030	BFA1-M12	61
BFA1035	BFA3-M12	61
BFA1040	GBF-M6-30	61
BFA1045	GBF-M8-30	61
BFA1050	GBF-M10-30	61
BFA1090	FBF-VAC-M	62
BFA1100	FBF-VAC-F	62

BUL		
BUL1000	BUL-VTE-M10-25	60
BUL1005	BUL-VTE-M10-30	60
BUL1008	BUL-DADO-M8	60
BUL1010	BUL-R-10,5	60
BUL1015	BUL-RG-10,5	60
BUL1020	BUL-TP21	60
BUL1025	BUL-TP41	60
BUL1050	BUL-VTE-M10-20-Z	60
BUL1052	BUL-VTE-M10-25-Z	60
BUL1055	BUL-VTE-M10-30-Z	60
BUL1060	BUL-DADO-M10-Z	60
BUL1065	BUL-R-10,5-Z	60
BUL1070	BUL-R-30-Z	60

CLP		
CLP1000	CLP-H1	12
CLP1005	CLP-H2	12
CLP1010	CLP-H3	12
CLP1015	CLP-H4	12
CLP1035	CLP-H2-I	12
CLP1040	CLP-H3-I	12
CLP1045	CLP-H2-IX	12
CLP1050	CLP-H3-IX	12
CLP1055	CLP-H1-CT	13
CLP1060	CLP-H2-CT	13
CLP1065	CLP-H3-CT	13
CLP1070	CLP-H4-CT	13
CLP1090	CLP-BF1-M6	14
CLP1095	CLP-BF2-M6	14
CLP1100	CLP-BF3-M6	14
CLP1105	CLP-BF4-M6	14
CLP1120	CLP-BF1-M8	14
CLP1125	CLP-BF2-M8	14
CLP1130	CLP-BF3-M8	14
CLP1135	CLP-BF4-M8	14
CLP1150	CLP-BF1-M10	14
CLP1155	CLP-BF2-M10	14

Codice	Riferimento	Pagina
CLP1160	CLP-BF3-M10	14
CLP1165	CLP-BF4-M10	14
CLP1170	CLP-ME2	17
CLP1175	CLP-ME3	17
CLP1180	CLP-ME4	17
CLP1200	CLP-ME2-V	17
CLP1205	CLP-ME3-V	17
CLP1210	CLP-ME4-V	17
CLP1215	CLP-1C89	16
CLP1220	CLP-1C1011	16
CLP1225	CLP-1C1214	16
CLP1230	CLP-1C1518	16
CLP1235	CLP-1C1924	16
CLP1240	CLP-1C2530	16
CLP1245	CLP-2C89	16
CLP1250	CLP-2C1011	16
CLP1255	CLP-2C1214	16
CLP1260	CLP-2C1518	16
CLP1265	CLP-2C1924	16
CLP1270	CLP-2C2530	16
CLP1275	CLP-3C89	16
CLP1280	CLP-3C1011	16
CLP1285	CLP-3C1214	16
CLP1290	CLP-3C1518	16
CLP1295	CLP-3C1924	16
CLP1300	CLP-3C2530	16
CLP1305	CLP-MBC	24
CLP1315	CLP-CFE	23
CLP1320	CLP-CFL	23
CLP1325	CLP-CFM11-E	23
CLP1330	CLP-CFM16-E	23
CLP1335	CLP-CFM25-E	23
CLP1340	CLP-CFM11-L	23
CLP1345	CLP-CFM16-L	23
CLP1350	CLP-CFM25-L	23
CLP1370	CLP-H1-F1214	15
CLP1375	CLP-H1-F1518	15
CLP1380	CLP-H1-F1924	15
CLP1385	CLP-H1-F2530	15
CLP1390	CLP-H2-F1214	15
CLP1395	CLP-H2-F1518	15
CLP1400	CLP-H2-F1924	15
CLP1405	CLP-H2-F2530	15
CLP1410	CLP-H3-F1214	15
CLP1415	CLP-H3-F1518	15
CLP1420	CLP-H3-F1924	15
CLP1425	CLP-H3-F2530	15
CLP1430	CLP-H4-F1214	15
CLP1435	CLP-H4-F1518	15
CLP1440	CLP-H4-F1924	15
CLP1445	CLP-H4-F2530	15
CLP1450	CLP-HK1	19
CLP1455	CLP-HK2	19

Codice	Riferimento	Pagina
CLP1465	CLP-HK4	19
CLP1470	CLP-HK1-CT	19
CLP1475	CLP-HK2-CT	19
CLP1485	CLP-HK4-CT	19
CLP1490	CLP-HK1-BF6	20
CLP1495	CLP-HK2-BF6	20
CLP1505	CLP-HK4-BF6	20
CLP1510	CLP-HK1-BF8	20
CLP1515	CLP-HK2-BF8	20
CLP1525	CLP-HK4-BF8	20
CLP1530	CLP-HK1-BF10	20
CLP1535	CLP-HK2-BF10	20
CLP1545	CLP-HK4-BF10	20
CLP1550	CLP-H1-PB	13
CLP1555	CLP-H2-PB	13
CLP1560	CLP-H3-PB	13
CLP1565	CLP-H4-PB	13
CLP1570	CLP-H1-FT1822	15
CLP1575	CLP-H1-FT2230	15
CLP1580	CLP-H1-FT3035	15
CLP1585	CLP-H2-FT1822	15
CLP1590	CLP-H2-FT2230	15
CLP1595	CLP-H2-FT3035	15
CLP1600	CLP-H3-FT1822	15
CLP1605	CLP-H3-FT2230	15
CLP1610	CLP-H3-FT3035	15
CLP1615	CLP-H4-FT1822	15
CLP1620	CLP-H4-FT2230	15
CLP1625	CLP-H4-FT3035	15
CLP1630	CLP-MBC-FTV1822	24
CLP1635	CLP-MBC-FTV2230	24
CLP1640	CLP-MBC-FTV3035	24
CLP1645	CLP-MBC-FTO1822	24
CLP1650	CLP-MBC-FTO2230	24
CLP1655	CLP-MBC-FTO3035	24
CLP1660	CLP-ME2-FT1822	18
CLP1665	CLP-ME2-FT2230	18
CLP1670	CLP-ME2FT3035	18
CLP1675	CLP-ME3-FT1822	18
CLP1680	CLP-ME3-FT2230	18
CLP1685	CLP-ME3FT3035	18
CLP1690	CLP-ME4-FT1822	18
CLP1695	CLP-ME4-FT2230	18
CLP1700	CLP-ME4FT3035	18
CLP1705	CLP-FT1822	26
CLP1710	CLP-FT2230	26
CLP1715	CLP-FT3035	26
CLP1720	CLP-VDM6	26
CLP1770	CLP-H1-LM	13
CLP1775	CLP-H2-LM	13
CLP1780	CLP-H3-LM	13
CLP1785	CLP-H4-LM	13
CLP1790	CLP-H1-MP	14

Codice	Riferimento	Pagina
CLP1795	CLP-H2-MP	14
CLP1800	CLP-H3-MP	14
CLP1805	CLP-H4-MP	14
CLP1810	CLP-RFP	22
CLP1815	CLP-TP4	27
CLP1820	CLP-HO	20
CLP1825	CLP-HO-BF6	21
CLP1830	CLP-HO-BF8	21
CLP1835	CLP-HO-BF10	21
CLP1840	CLP-HO-PB	21
CLP1845	CLP-HO-MP4	21
CLP1850	CLP-HO-MP6	21
CLP1855	CLP-MPD4	23
CLP1860	CLP-MPD6	23
CLP1865	CLP-CF-MPL	23
CLP1870	CLP-CF-MPH4N	23
CLP1875	CLP-CF-MPH6N	23
CLP1915	CLP-BF-M6	26
CLP1920	CLP-BF-M8	26
CLP1925	CLP-BF-M10	26
CLP1930	CLP-CT	27
CLP2000	CLP-QJ1-FTO1822	25
CLP2005	CLP-QJ1-FTO2230	25
CLP2010	CLP-QJ1-FTO3035	25
CLP2015	CLP-QJ2-FTO1822	25
CLP2020	CLP-QJ2-FTO2230	25
CLP2025	CLP-QJ2-FTO3035	25
CLP2030	CLP-QJ3-FTO1822	25
CLP2035	CLP-QJ3-FTO2230	25
CLP2040	CLP-QJ3-FTO3035	25
CLP2100	CLP-QJ1	25
CLP2105	CLP-QJ2	25
CLP2110	CLP-QJ3	25

CPR		
CPR2000	CPR-I-050	63
CPR2005	CPR-I-075	63
CPR2010	CPR-I-100	63
CPR2015	CPR-I-125	63
CPR2020	CPR-I-150	63
CPR2025	CPR-I-200	63
CPR2030	CPR-I-250	63
CPR2035	CPR-I-300	63
CPR2040	CPR-I-400	63

CTN		
CTN1000	CTN-L-Box	62
CTN1005	CTN-M-Box	62
CTN1010	CTN-P-Box	62
CTN1015	CTN-M-Max	62
CTN1020	CTN-P-Max	62
CTN1025	CTN-GS	62
CTN1030	CTN-OM8	62

DAP		
DAP1000	DAP-M6S	56
DAP1005	DAP-M8S	56
DAP1010	DAP-M10S	56
DAP1015	DAP-M12S	56
DAP1020	DAP-M6C	56
DAP1025	DAP-M8C	56
DAP1030	DAP-M10C	56
DAP1035	DAP-M12C	56
DAP1040	DAP-M6L	56
DAP1045	DAP-M8L	56
DAP1050	DAP-M10L	56
DAP1055	DAP-M12L	56
DAP1060	DAP-FK8	58
DAP1065	DAP-FK10	58
DAP1070	DAP-FK12	58
DAP1075	DAP-FK-M8x40	58
DAP1080	DAP-FK-M8x60	58
DAP1085	DAP-FK-M10x40	58
DAP1090	DAP-FK-M10x60	58
DAP1100	DAP-FKA-6	57
DAP1105	DAP-FKA-8	57
DAP1110	DAP-FKA-10	57
DAP1115	DAP-FKA-12	57
DAP2000	DAP-M6S-ZC	56
DAP2005	DAP-M8S-ZC	56
DAP2010	DAP-M10S-ZC	56
DAP2020	DAP-M6C-ZC	56
DAP2025	DAP-M8-C-ZC	56
DAP2030	DAP-M10-C-ZC	56
DAP2040	DAP-M6-L-ZC	56
DAP2045	DAP-M8-L-ZC	56
DAP2050	DAP-M10-L-ZC	56
DAP3005	DAP-M8-S-SS	57
DAP3010	DAP-M10-S-SS	57
DAP3025	DAP-M8-C-SS	57
DAP3030	DAP-M10-C-SS	57
DAP3045	DAP-M8L-SS	57
DAP3050	DAP-M10L-SS	57

FTC		
FTC2021	FTU-41x21	66
FTC2041	FTU-41x41	66

FVT		
FVT1270	FVS-AV-ZC	50
FVT1320	FVA-TE-8X16-INOX	59
FVT1325	FVA-TE-10X20-INOX	59
FVT1330	FVA-TCEI-8X10-INOX	59
FVT1331	FVA-TCEI-8X60-INOX	59
FVT1332	FVA-TCEI-8X20-INOX	59
FVT1333	FVA-TCEI-8X65-INOX	59
FVT1334	FVA-TCEI-8X75-INOX	59

Codice	Riferimento	Pagina
FVT1335	FVA-TCEI-8X25-INOX	59
FVT1337	FVA-TCEI-8X30-INOX	59
FVT1338	FVA-TCEI-8X35-INOX	59
FVT1340	FVA-TCEI-8X40-INOX	59
FVT1341	FVA-TCEI-8X45-INOX	59
FVT1342	FVA-TCEI-8X50-INOX	59
FVT1343	FVA-TCEI-8X55-INOX	59
FVT1344	FVA-TCEI-8X70-INOX	59
FVT1345	FVA-TCEI-10X25-INOX	59
FVT1346	FVA-TCEI-10X20-INOX	59
FVT1347	FVA-TCEI-10X30-INOX	59
FVT1350	FVA-TCEI-10X40-INOX	59
FVT1355	FVA-TCEI-10X50-INOX	59
FVT1358	FVA-DR-M8-INOX	59
FVT1359	FVA-DR-M10-INOX	59
FVT1395	FVA-TM-8X30-ZC	58
FVT1400	FVA-TM-10X30-ZC	58
FVT1405	FVA-BF-M8-INOX	61
FVT1410	FVA-BF-M10-INOX	61
FVT1415	FVA-MF-8x30-INOX	61
FVT1420	FVA-MF-10x30-INOX	61

MRT		
MRT1000	MRT-S24	65
MRT1005	MRT-S32	65
MRT1010	MRT-S45	65
MRT1105	MRT-C21	65
MRT1110	MRT-C27	65
MRT1115	MRT-C33	65
MRT1120	MRT-C39	65
MRT1122	MRT-C40	65
MRT1125	MRT-C50	65
MRT1130	MRT-C64	65

MSL		
MSL1000	MSL-P300-D-Z	45
MSL1005	MSL-P400-D-Z	45
MSL1010	MSL-P500-D-Z	45
MSL1015	MSL-P600-D-Z	45
MSL1020	MSL-P750-D-Z	45
MSL1030	MSL-P900-D-Z	45
MSL1035	MSL-P1000-D-Z	45
MSL1040	MSL-P150-F-Z	45
MSL1045	MSL-P200-F-Z	45
MSL1050	MSL-P300-F-Z	45
MSL1055	MSL-P450-F-Z	45
MSL1060	MSL-P500-F-Z	45
MSL1065	MSL-P600-F-Z	45
MSL1070	MSL-P750-F-Z	45
MSL1071	MSL-P900-F-Z	45
MSL1072	MSL-P1000-F-Z	45
MSL1500	MSL-L110-F-E	46
MSL1505	MSL-L160-F-E	46

Codice	Riferimento	Pagina
MSL1510	MSL-L210-F-E	46
MSL1515	MSL-L310-F-E	46
MSL1520	MSL-L410-F-E	46
MSL1525	MSL-L510-F-E	46
MSL1530	MSL-L610-F-E	46
MSL2000	MSL-L110-FC-Z	46
MSL2005	MSL-L160-FC-Z	46
MSL2010	MSL-L210-FC-Z	46
MSL2015	MSL-L310-FC-Z	46
MSL2020	MSL-L410-FC-Z	46
MSL2025	MSL-L510-FC-Z	46
MSL2030	MSL-L610-FC-Z	46

PCL		
PCL1000	PCL-G-3/8	64
PCL1005	PCL-G-1/2	64
PCL1010	PCL-G-3/4	64
PCL1015	PCL-G-1	64
PCL1020	PCL-G-1-1/4	64
PCL1025	PCL-G-1-1/2	64
PCL1030	PCL-G-2	64
PCL1035	PCL-G-2-1/2	64
PCL1040	PCL-G-3	64
PCL1045	PCL-G-4	64
PCL1050	PCL-G-5	64

PRF		
PRF1085	PRF-A3D-SF	29
PRF1090	PRF-A4D-SF	29
PRF1095	PRF-A6D-SF	29
PRF1105	PRF-A3D-ZF	29
PRF1110	PRF-A4D-ZF	29
PRF1115	PRF-A6D-ZF	29
PRF1125	PRF-B3-SF	30
PRF1130	PRF-B4-SF	30
PRF1135	PRF-B6-SF	30
PRF1145	PRF-B3-ZF	30
PRF1150	PRF-B4-ZF	30
PRF1155	PRF-B6-ZF	30
PRF1165	PRF-A3-SF	30
PRF1170	PRF-A4-SF	30
PRF1175	PRF-A6-SF	30
PRF1185	PRF-A3-ZF	30
PRF1190	PRF-A4-ZF	30
PRF1195	PRF-A6-ZF	30
PRF1205	PRF-A3-SF3	31
PRF1210	PRF-A4-SF3	31
PRF1215	PRF-A6-SF3	31
PRF1225	PRF-A3-ZF3	31
PRF1230	PRF-A4-ZF3	31
PRF1235	PRF-A6-ZF3	31
PRF1275	PRF-B3D-S	29
PRF1280	PRF-B4D-S	29

Codice	Riferimento	Pagina
PRF1285	PRF-B6D-S	31
PRF1295	PRF-B3D-Z	31
PRF1300	PRF-B4D-Z	31
PRF1305	PRF-B6D-Z	31
PRF1500	PRF-RB3-SF	31
PRF1505	PRF-RB4-SF	31
PRF1510	PRF-RB6-SF	31
PRF1515	PRF-RB3-ZF	31
PRF1520	PRF-RB4-ZF	31
PRF1525	PRF-RB6-ZF	31
PRF1530	PRF-RA3-SF	32
PRF1535	PRF-RA4-SF	32
PRF1540	PRF-RA6-SF	32
PRF1545	PRF-RA3-ZF	32
PRF1550	PRF-RA4-ZF	32
PRF1555	PRF-RA6-ZF	32
PRF1560	PRF-RA3-SF3	32
PRF1565	PRF-RA4-SF3	32
PRF1570	PRF-RA6-SF3	32
PRF1575	PRF-RA3-ZF3	32
PRF1580	PRF-RA4-ZF3	32
PRF1585	PRF-RA6-ZF3	32
PRF2000	PRF-B3-MF3	34
PRF2100	PRF-A3-MF3	34
PRF2200	PRF-LB3-MF	35
PRF2250	PRF-LA3-MF	35
PRF9000	PRF-A3-SSF	36
PRF9004	PRF-B3-SSF	36

STF		
STF1000	STF-P2	48
STF1005	STF-P3	48
STF1010	STF-P4	48
STF1012	STF-GI-PB-Inox	37
STF1013	STF-GI-PA-Inox	37
STF1015	STF-PL3	48
STF1020	STF-PT4	48
STF1022	STF-PC4	48
STF1025	STF-O41	49
STF1030	STF-O21	49
STF1035	STF-O82	49
STF1036	STF-O82-0	49
STF1040	STF-Z21	49
STF1045	STF-Z41	49
STF1050	STF-B41	50
STF1056	STF-B82	50
STF1065	STF-C41	50
STF1066	STF-C41-2	50
STF1076	STF-G21-G41	51
STF1081	STF-G82	51
STF1095	STF-GP41	51
STF1096	STF-GI	51
STF1100	STF-W45	54

Codice	Riferimento	Pagina
STF1101	STF-W30A	54
STF1102	SFT-W30-90A	54
STF1105	STF-WL2	54
STF1110	STF-WL3	54
STF1115	STF-WL4	54
STF1120	STF-WL4R	54
STF1131	STF-PP9-E	50
STF1132	STF-PP11-E	50
STF1135	STF-PP13,5	50
STF1140	STF-SR300	50
STF1145	STF-W45A	54
STF1150	STF-AV-PR	51
STF1155	STF-AV-BF	51
STF2500	STF-GLE-30	52
STF2505	STF-PLE-30	52
STF2510	STF-PLE-40	52
STF2515	STF-PLE-50	52
STF2520	STF-PLE-60	52
STF3000	STF-GPE41	53
STF9012	STF-GI-PD-Inox	37

TKM		
TKM1000	TKM-M6	64
TKM1005	TKM8	64
TKM1010	TKM-M8	64
TKM1015	TKM10	64
TKM1020	TKM-M10	64
TKM1025	TKM12	64
TKM1030	TKM-M12	64
TKM1035	TKM-M16	64

UBT		
UBT1000	UBT-1/2'-6	63
UBT1005	UBT-3/4'-6	63
UBT1010	UBT-1'-6	63
UBT1015	UBT-1'1/4'-8	63
UBT1020	UBT-1'1/2'-8	63
UBT1025	UBT-2'-8	63
UBT1030	UBT-2'1/2'-8	63
UBT1035	UBT-3'-8	63
UBT1040	UBT-4'-8	63

ZCT		
ZCT1000	ZLG1	72
ZCT1005	ZLG2	72
ZCT1010	ZLG3	72
ZCT1012	ZLG4	72
ZCT1015	ZLG5	72
ZCT1020	ZLG10	72
ZCT1025	ZLS1	72
ZCT1030	ZLS2	72
ZCT1035	ZLS3	72
ZCT1037	ZLS4	72

Codice	Riferimento	Pagina
ZCT1040	ZLS5	72
ZCT1045	ZLS10	72
ZCT1050	ZLY1	72
ZCT1055	ZLY2	72
ZCT1060	ZLY3	72
ZCT1062	ZLY4	72
ZCT1065	ZLY5	72
ZCT1070	ZLY10	72
ZCT1075	CLG1	73
ZCT1080	CLG2	73
ZCT1085	CLG3	73
ZCT1087	CLG4	73
ZCT1090	CLG5	73
ZCT1095	CLG10	73
ZCT1100	CLS1	73
ZCT1105	CLS2	73
ZCT1110	CLS3	73
ZCT1112	CLS4	73
ZCT1115	CLS5	73
ZCT1120	CLS10	73
ZCT1125	CLY1	73
ZCT1130	CLY2	73
ZCT1135	CLY3	73
ZCT1137	CLY4	73
ZCT1140	CLY5	73
ZCT1145	CLY10	73
ZCT1150	KLG1	78
ZCT1155	KLG2	78
ZCT1160	KLG3	78
ZCT1162	KLG4	78
ZCT1165	KLG5	78
ZCT1170	KLG10	78
ZCT1175	KLS1	78
ZCT1180	KLS2	78
ZCT1185	KLS3	78
ZCT1187	KLS4	78
ZCT1190	KLS5	78
ZCT1195	KLS10	78
ZCT1205	TRS150-200	78
ZCT1210	TRS300-400	78
ZCT1220	LUM-150-200	78
ZCT1225	LUM-300-400	78
ZCT1230	UNI1	79
ZCT1235	UNI2	79
ZCT1240	CPA1	79
ZCT1245	PVC1	79
ZCT1250	CUT1	79
ZCT1255	CUT3	79
ZCT1260	TT1	79
ZCT2005	R200GREEN	69
ZCT2010	R500GREEN	69
ZCT2015	R100SILVER	69
ZCT2020	R200SILVER	69

Codice	Riferimento	Pagina
ZCT2040	R100YELLOW	69
ZCT2050	R100PURPLE	69
ZCT2052	R100NECT	69
ZCT2055	PLE1GREEN	70
ZCT2057	PLE2GREEN	70
ZCT2060	PLE3GREEN	70
ZCT2062	PLE4GREEN	70
ZCT2065	PLE5GREEN	70
ZCT2070	PLE1SILVER	70
ZCT2072	PLE2SILVER	70
ZCT2075	PLE3SILVER	70
ZCT2077	PLE4SILVER	70
ZCT2080	PLE5SILVER	70
ZCT2082	PLE10SILVER	70
ZCT2100	PTE1GREEN	71
ZCT2102	PTE2GREEN	71
ZCT2105	PTE3GREEN	71
ZCT2107	PTE4GREEN	71
ZCT2110	PTE5GREEN	71
ZCT2115	PTE1SILVER	71
ZCT2117	PTE2SILVER	71
ZCT2120	PTE3SILVER	71
ZCT2122	PTE4SILVER	71
ZCT2125	PTE5SILVER	71
ZCT2130	PTE1YELLOW	71
ZCT2132	PTE2YELLOW	71
ZCT2135	PTE3YELLOW	71
ZCT2137	PTE4YELLOW	71
ZCT2140	PTE5YELLOW	71
ZCT2150	PLE1YELLOW	70
ZCT2152	PLE2YELLOW	70
ZCT2155	PLE3YELLOW	70
ZCT2157	PLE4YELLOW	70
ZCT2160	PLE5YELLOW	70
ZCT2200	CL-SL-100	76
ZCT2210	CL-SL-150	76
ZCT2235	PLE-SL-2S	77
ZCT2240	PLE-SL-3S	77
ZCT2250	PLE-SL-5S	77
ZCT2265	PLE-SL-2Y	77
ZCT2270	PLE-SL-5Y	77
ZCT2280	PLE-SL-5Y	77
ZCT2305	CL-SL-2S	77
ZCT2310	CL-SL-3S	77
ZCT2320	CL-SL-5S	77
ZCT2335	CL-SL-2Y	77
ZCT2340	CL-SL-3Y	77
ZCT2350	CL-SL-5Y	77
ZCT2500	KIT-FSG-TR	74
ZCT2510	GLS-M6-1	75
ZCT2520	GLS-M6-3	75
ZCT2530	GLS-M6-5	75
ZCT2550	GLS-M8-1	75

Codice	Riferimento	Pagina
ZCT2560	GLS-M8-3	75
ZCT2570	GLS-M8-5	75
ZCT3000	KL50	69
ZCT3005	KL100	69
ZCT3010	KL150	69
ZCT3015	KL200	69
ZCT3018	KL600	69
ZCT3020	KL50PK	69
ZCT3025	KL100PK	69
ZCT3030	KL150PK	69
ZCT3035	KL200PK	69
ZCT3050	KL150LOK	69
ZCT3055	KL200LOK	69
ZCT3060	KL600LOK	69
ZCT9015	KITGREEN-C&M	69
ZCT9016	KITSILVER-C&M	69

Codice	Riferimento	Pag.
BUL		
BUL1020	BUL-TP21	110
BUL1025	BUL-TP41	110

DAP		
DAP2000	DAP-M6-S-ZC	105
DAP2005	DAP-M8-S-ZC	105
DAP2010	DAP-M10-S-ZC	105
DAP2020	DAP-M6-C-ZC	105
DAP2025	DAP-M8-C-ZC	105
DAP2030	DAP-M10-C-ZC	105
DAP2040	DAP-M6-L-ZC	105
DAP2045	DAP-M8-L-ZC	105
DAP2050	DAP-M10-L-ZC	105
DAP3005	DAP-M8-S-SS	105
DAP3010	DAP-M10-S-SS	105
DAP3025	DAP-M8-C-SS	105
DAP3030	DAP-M10-C-SS	105
DAP3045	DAP-M8L-SS	105
DAP3050	DAP-M10L-SS	105

FVT		
FVT1004	FVP-L3.1-RI-ALU	82
FVT1005	FVP-L6.2-S-ALU	82
FVT1009	FVP-L6.2-RI-ALU	82
FVT1011	FVP-L3.1-ANG-ALU	83
FVT1012	FVP-L6.2-ANG-ALU	83
FVT1015	FVP-L6.2-SL-ALU	82
FVT1016	FVP-L3.1-UNI-ALU	83
FVT1017	FVP-L4.2-UNI-ALU	83
FVT1018	FVP-L6.2-UNI-ALU	83
FVT1019	FVP-L0.4-UNI-ALU	83
FVT1021	FVP-L3.3-S-ALU	82
FVT1023	FVP-L3.3-SL-ALU	82
FVT1024	FVP-L4.4-SL-ALU	82
FVT1026	FVP-L4.4-S-ALU	82
FVT1040	FVS-Z33-INOX	86
FVT1045	FVS-Z34-INOX	86
FVT1050	FVS-Z35-INOX	86
FVT1055	FVS-Z37-INOX	86
FVT1060	FVS-Z39-INOX	86
FVT1065	FVS-Z41-INOX	86
FVT1066	FVS-Z43-INOX	86
FVT1070	FVS-Z45-INOX	86
FVT1075	FVS-Z47-INOX	86
FVT1080	FVS-Z49-INOX	86
FVT1111	FVS-Z-U-EVO	87
FVT1113	FVT-FPP-INOX	87
FVT1115	FVS-PU-INOX	83
FVT1118	FVSO-S-125-INOX	89
FVT1246	FVS-S-RGL-EVO	90
FVT1252	FVSO-P-RGL-SS	89
FVT1256	FVS-P-RGL-EVO	90

Codice	Riferimento	Pag.
FVT1262	FVS-CST-RGL-INOX	91
FVT1267	FVS-R-RGL-INOX	91
FVT1270	FVS-AV-ZC	104
FVT1286	FVT-SCV-ALU	99
FVT1287	FVT-SCV-S-ALU	99
FVT1288	FVT-SCV-S-ALU	99
FVT1299	FVT-SLG-MRS-INOX	92
FVT1300	FVA-AF-10X200-INOX	96
FVT1305	FVA-AF-10X250-INOX	96
FVT1310	FVA-AF-12X250-INOX	96
FVT1315	FVA-AF-12X300-INOX	96
FVT1316	FVA-AF-12X350-INOX	96
FVT1318	FVA-AF-100-50M10-INOX	96
FVT1319	FVA-AF-150-50M10-INOX	96
FVT1320	FVA-TE-8x16-INOX	107
FVT1325	FVA-TE-10x20-INOX	107
FVT1330	FVA-TCEI-8x10-INOX	106
FVT1331	FVA-TCEI-8x60-INOX	106
FVT1332	FVA-TCEI-8x20-INOX	106
FVT1333	FVA-TCEI-8x65-INOX	106
FVT1334	FVA-TCEI-8x75-INOX	106
FVT1335	FVA-TCEI-8x25-INOX	106
FVT1337	FVA-TCEI-8x30-INOX	106
FVT1338	FVA-TCEI-8x35-INOX	106
FVT1340	FVA-TCEI-8x40-INOX	106
FVT1341	FVA-TCEI-8x45-INOX	106
FVT1342	FVA-TCEI-8x50-INOX	106
FVT1343	FVA-TCEI-8x55-INOX	106
FVT1344	FVA-TCEI-8x70-INOX	106
FVT1345	FVA-TCEI-10x25-INOX	106
FVT1346	FVA-TCEI-10x20-INOX	106
FVT1347	FVA-TCEI-10x30-INOX	106
FVT1350	FVA-TCEI-10x40-INOX	106
FVT1355	FVA-TCEI-10x50-INOX	106
FVT1356	FVA-SA-8-INOX	107
FVT1358	FVA-DR-M8-INOX	107
FVT1359	FVA-DR-M10-INOX	107
FVT1395	FVA-TM-8X30-E	106
FVT1400	FVA-TM-10X30-E	106
FVT1405	FVA-BF-M8-INOX	108
FVT1410	FVA-BF-M10-INOX	108
FVT1415	FVA-MF-8x30-INOX	108
FVT1420	FVA-MF-10x30-INOX	108
FVT1454	FVV-ZVC-30	100
FVT1457	FVV-ZVC	100
FVT1458	FVV-ZVC-30-1	101
FVT1459	FVV-ZVC-30-2	101
FVT1461	FVV-ZVC-6-52	102
FVT1462	FVV-ZVC-6-28	102
FVT1465	FVV-ZVC-1002	101
FVT1466	FVV-ZVC-10-62	102
FVT1467	FVV-ZVC-10-25	102
FVT1511	FVT-TRG-R-EVO	98

Codice	Riferimento	Pag.
FVT1512	FVT-TRG-OR	98
FVT1514	FVT-TRG-DP-V	99
FVT1515	FVT-P2-SS	97
FVT1517	FVT-TRG-DP-O	99
FVT1530	FVT-GN-120	111
FVT1535	FVT-GN-80	111
FVT1550	FVT-GBU-50	111
FVT1551	FVT-GBU-10	111
FVT1552	FVT-GBU-120	111
FVT1558	FVT-MG-1200	111
FVT3031	FVS-Z-31-ALU	86
FVT3034	FVS-Z-34-ALU	86
FVT3036	FVS-Z-36-ALU	86
FVT3039	FVS-Z-39-ALU	86
FVT3041	FVS-Z-41-ALU	86
FVT3044	FVS-Z-44-ALU	86
FVT3046	FVS-Z-46-ALU	86
FVT3049	FVS-Z-49-ALU	86
FVT3051	FVS-Z-51-ALU	86
FVT3112	FVS-Q-U-ALU	87
FVT4031	FVS-ZP-31-ALU	88
FVT4034	FVS-ZP-34-ALU	88
FVT4036	FVS-ZP-36-ALU	88
FVT4039	FVS-ZP-39-ALU	88
FVT4041	FVS-ZP-41-ALU	88
FVT4044	FVS-ZP-44-ALU	88
FVT4046	FVS-ZP-46-ALU	88
FVT4049	FVS-ZP-49-ALU	88
FVT4051	FVS-ZP-51-ALU	88
FVT4114	FVS-Q-UP-ALU-29-35	88
FVT4115	FVS-Q-UP-ALU-36-45	88
FVT4116	FVS-Q-UP-ALU-46-51	88
FVT5000	FVT-SLG-U080-INOX	93
FVT5030	FVS-UP-30-INOX	94
FVT5033	FVS-UP-33-INOX	94
FVT5036	FVS-UP-36-INOX	94
FVT5038	FVS-UP-38-INOX	94
FVT5041	FVS-UP-41-INOX	94
FVT5043	FVS-UP-43-INOX	94
FVT5046	FVS-UP-46-INOX	94
FVT5048	FVS-UP-48-INOX	94
FVT5051	FVS-UP-51-INOX	94
FVT50XX	Dima di Fissaggio	93
FVT5120	FVP-L120-RI-ALU	95
FVT5250	FVP-L230-RI-ALU	95
FVT5300	FVP-L280-RI-ALU	95
FVT5400	FVP-L363-RI-ALU	95
FVT9200	FVA-VAC-8-80	110
FVT9201	FVA-VAC-8-60	110
FVT9210	FVA-VAC-IA	110
FVT9457	FVV-ZMP-C	101
FVT9470	RIV-ST-52-191-ALU	109
FVT95XX	FVT-SLG-R	92

Codice	Riferimento	Pag.
FVT96XX	FVT-SLG-P	92
FVT95016	FVT-TSV	98
FVT95017	FVT-TDH	98

PRF		
PRF1145	PRF-B3-ZF	84
PRF1150	PRF-B4-ZF	84
PRF1155	PRF-B6-ZF	84
PRF1225	PRF-A3-ZF3	84
PRF1230	PRF-A4-ZF3	84
PRF1235	PRF-A6-ZF3	84
PRF9000	PRF-A3-SSF	84
PRF9004	PRF-B3-SSF	84

RPB		
RPB1005	RPB 125-14	112

RPU		
RPU3010	RPU 250-11 S	112
RPU3015	RPU 400-11 S	112

STF		
STF1012	STF-GI-PB-Inox	85
STF1013	STF-GI-PA-Inox	85
STF1025	STF-041	104
STF1030	STF-021	104
STF1035	STF-82	104

Codice	Riferimento	Pag.
STF1050	STF-B41	104
STF1100	STF-W45	103
STF1101	STF-W30A	103
STF1102	STF-W30-90A	103
STF1105	STF-WL2	103
STF1110	STF-WL3	103
STF1115	STF-WL4	103
STF1120	STF-WL4R	103
STF1140	STF-SR300	105



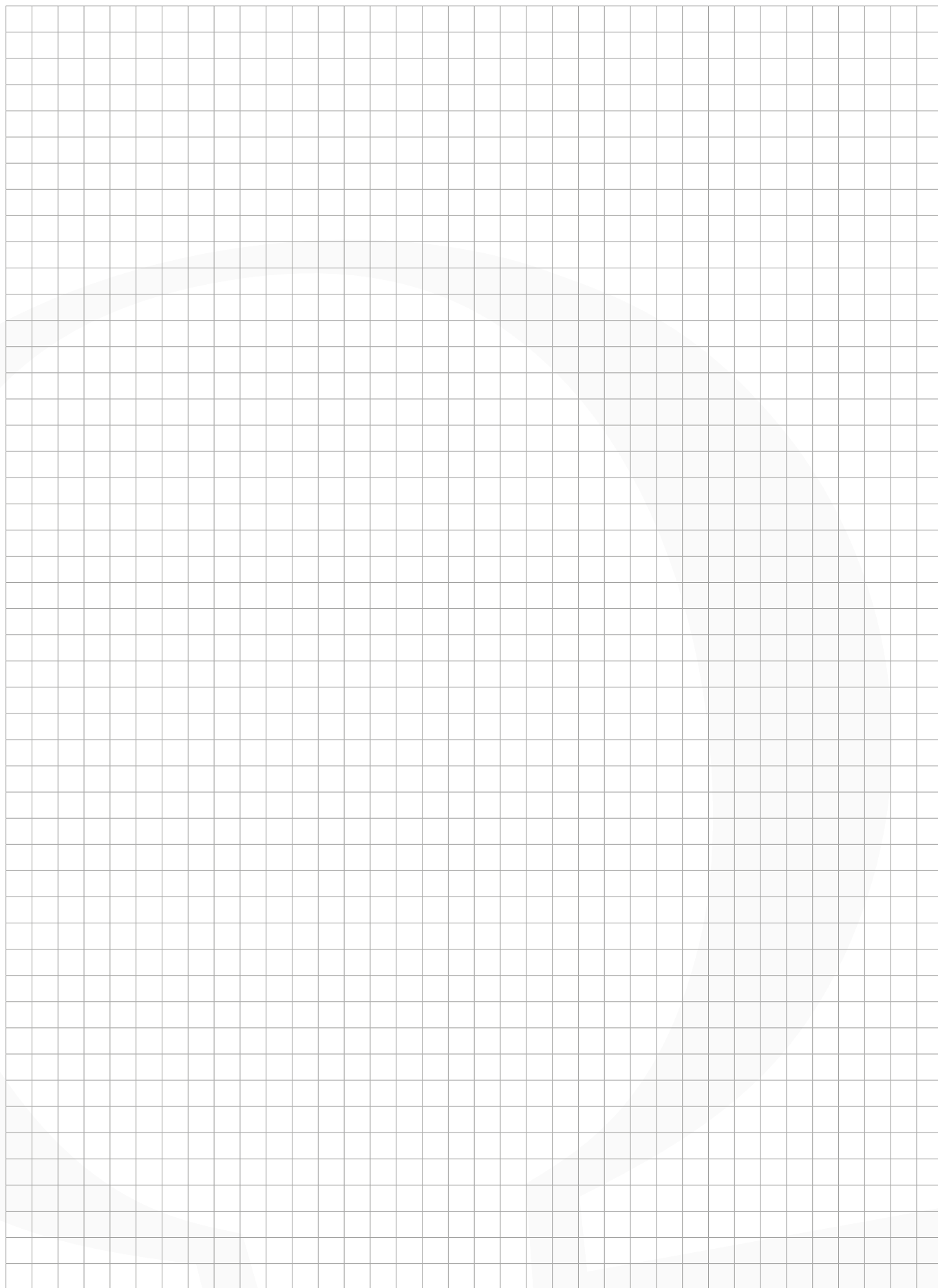

NOTE

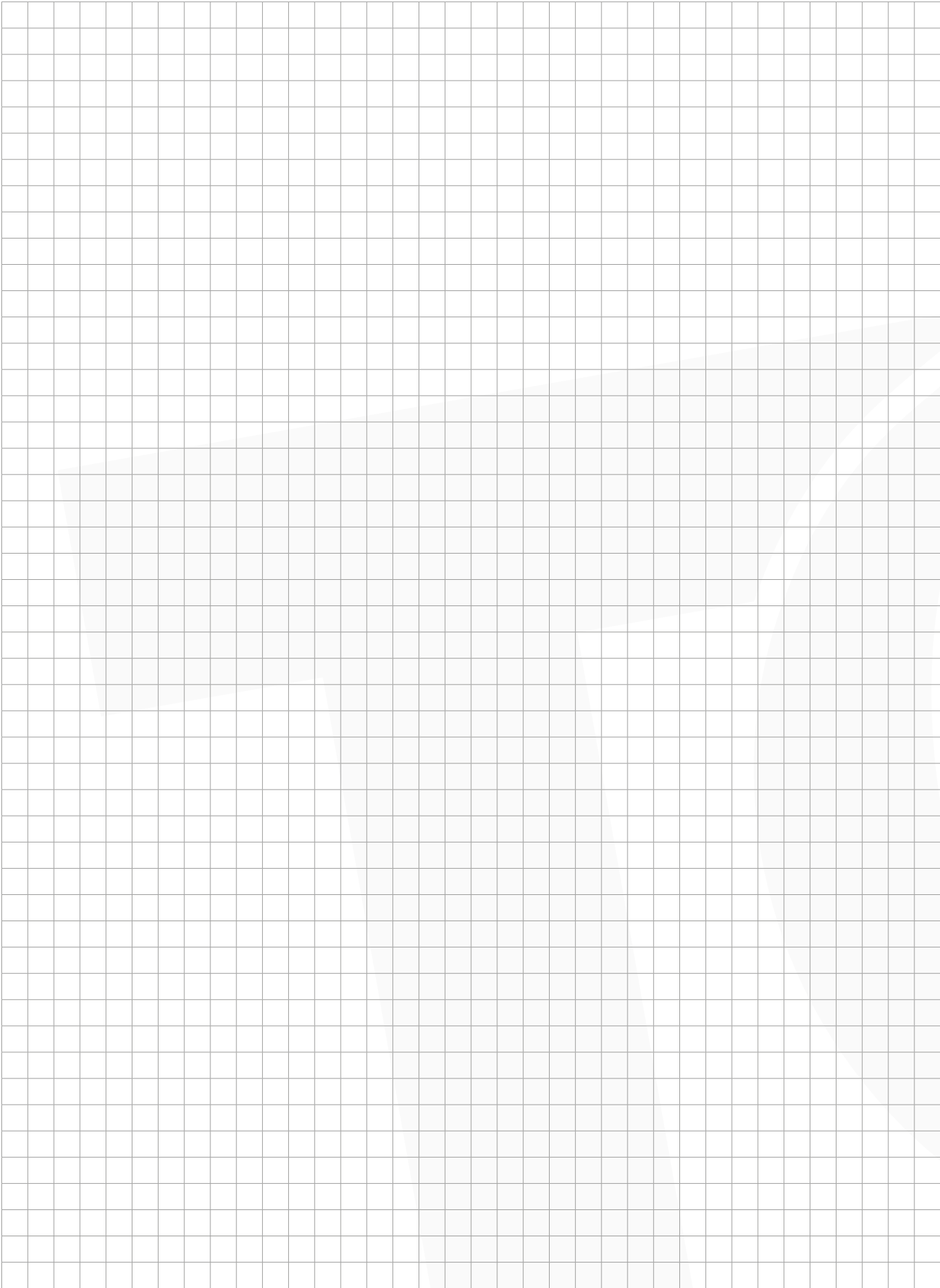



Centro Logistico
www.teknomega.it

Buccinasco (MI)



Teknomega Industrie
www.teknomega.it

Piacenza



Filiale Spagnola
www.teknomega.es

Barcellona



**Richiedi i cataloghi scrivendo a:
info@teknomega.it**



Via Enrico Fermi, 27 - 20090 Buccinasco (MI)
Tel.: +39-0248844281 - Fax: +39-0245705673
info@teknomega.com - www.teknomega.com



Teknomega s.r.l.

via E. Fermi, 27 - 20090 Buccinasco (MI)
Tel. +39 02 45707533 +39 02 48844281
Fax +39 02 45705673
e-mail: info@teknomega.it
www.teknomega.it

ED. FIX 11/20 IT
Pubblicazione non destinata alla vendita